

PQS

PRACTICAL QUALITY SYSTEMS
Fast Custom Manufacturing - Nationwide Installation Services

Partner Tech EM-200 Two Screen Enclosed Countertop Mount PN 80921



Also available in stainless steel (see PN 80921-SS)

info@practicalqualitysystems.com WWW.PRACTICALQUALITYSYSTEMS.COM

(818) 993-1022

ALL PRODUCTS PATENT PENDING

Partner Tech EM-200 Two Screen Enclosed Countertop Mount PN 80921

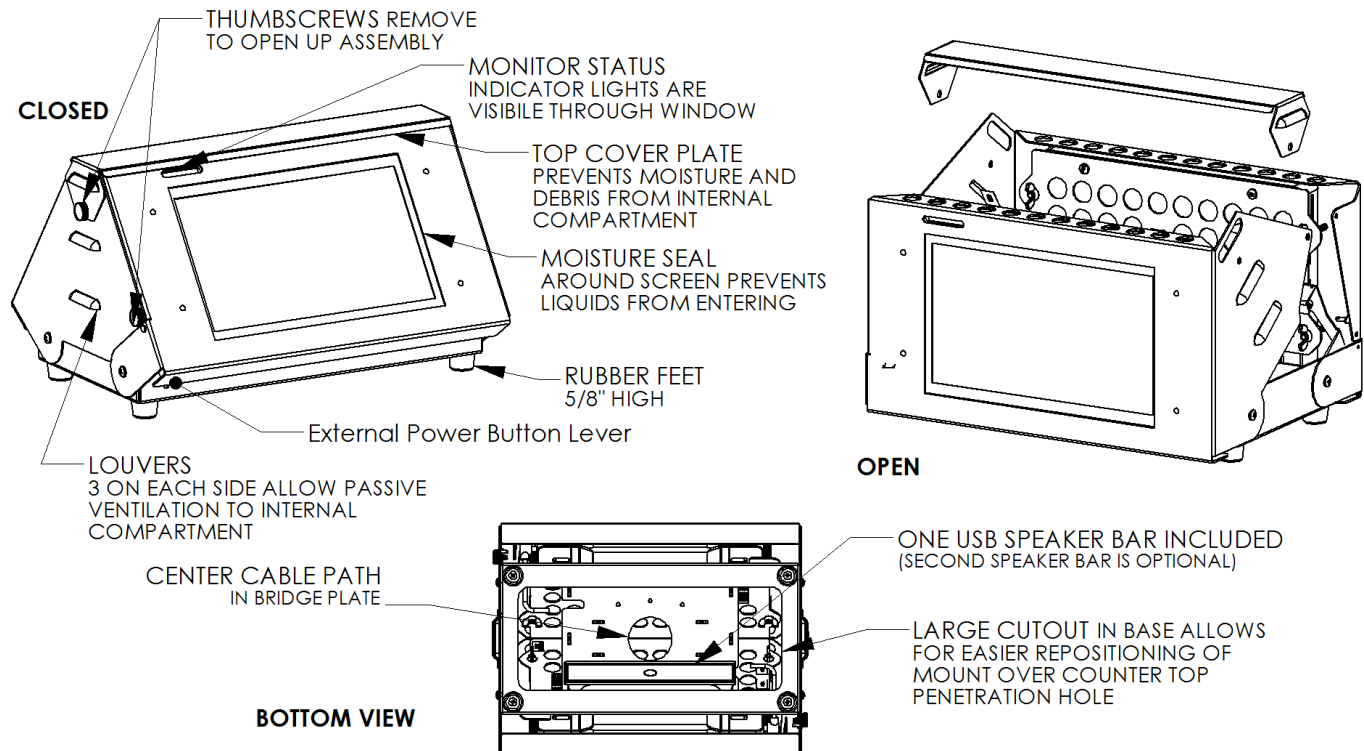

PRODUCT SPECIFICATIONS

- Supports two Partner Tech EM-200 touch terminals mounted inside of the enclosure to provide complete protection against falling liquids and dust.
- Meets NEMA Type 2 rating- Enclosures constructed for indoor use to provide a degree of protection to personnel against access to hazardous parts. Also provides a degree of protection of the equipment inside the enclosure against ingress of solid foreign objects (falling dirt) and protection from harmful effects on the equipment due to the ingress of water (dripping and light splashing).
- External power button lever easily actuates the power on/off button on the side of the computer.
- Storage area in base also conceals and protects power supplies, connectors, power strip, USB speaker bar and data cabling.
- A close fitting gasket surrounds the entire edge of the touch screens to seal them against liquid entry.
- Downward facing Louvers located near the top on both sides of the enclosure allow passive ventilation.
- The interior includes multiple tie points to secure power supply and data cabling.
- Large opening in base allows for easier repositioning of mount over counter top penetration hole.
- Included spiral wrap sleeve protects data and power cables.
- Four 5/8" tall rubber feet raise the entire enclosure above the counter top to help protect it from liquids and make it easy to rotate.
- Thumbscrews secure the *front cover plates* and *top cover plate* in the closed position but are removable for easy access to internal storage area.
- Thumbscrews secure terminals to *mounting plates* while wing nuts secure mounting plates to the *front cover plates* for easy installation and removal that requires no tools.
- Each assembly includes one USB speaker bar that connects to the bartender-side screen to increase the sound level of the "order up" audio prompts. A second speaker bar can be added if desired for the other screen.
- To order this assembly use part number 80921. This assembly is also available in stainless steel. (Use PN 80921-SS)

Partner Tech EM-200 Two Screen Enclosed Countertop Mount PN 80921

Slide power button lever to the left to actuate power button

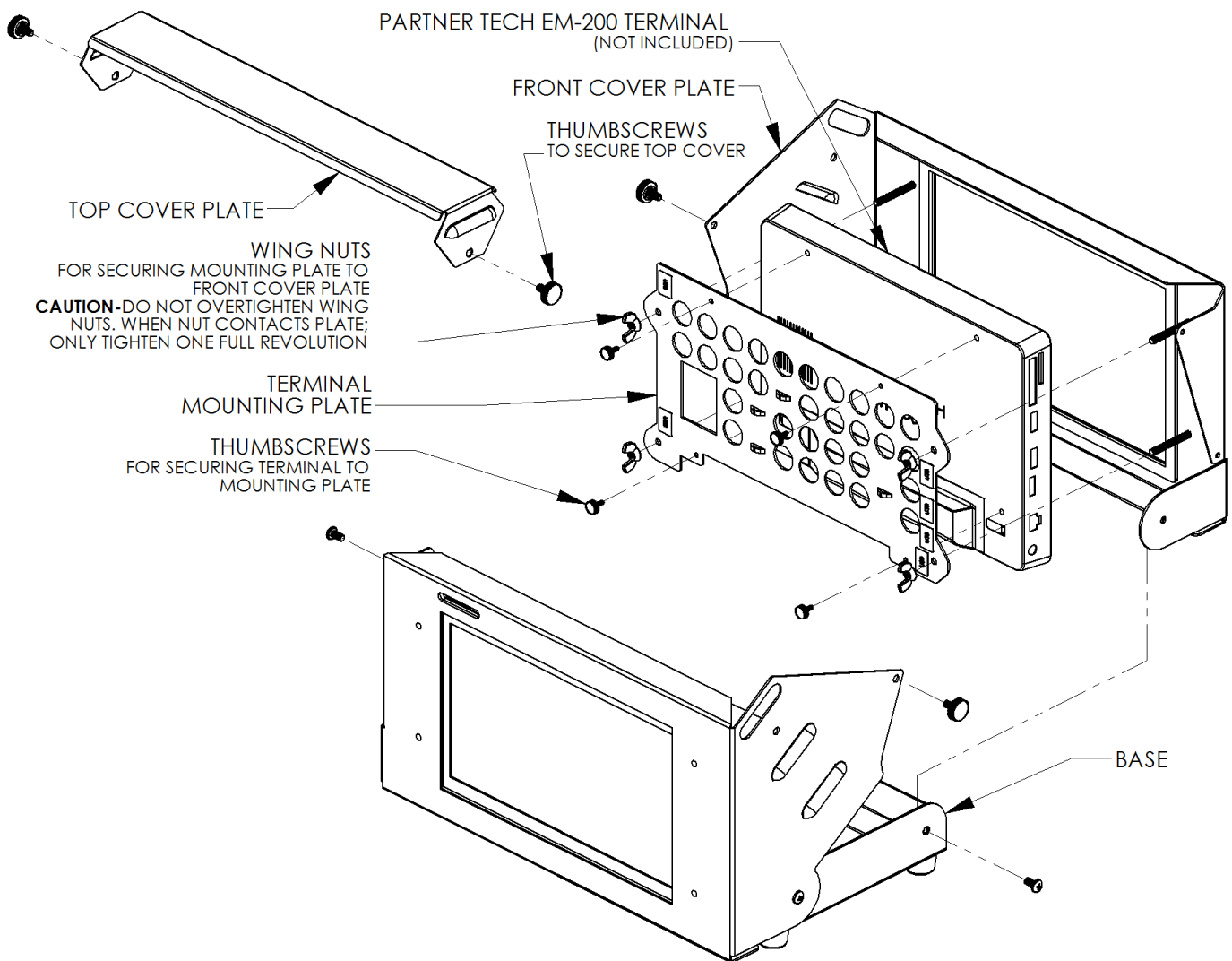
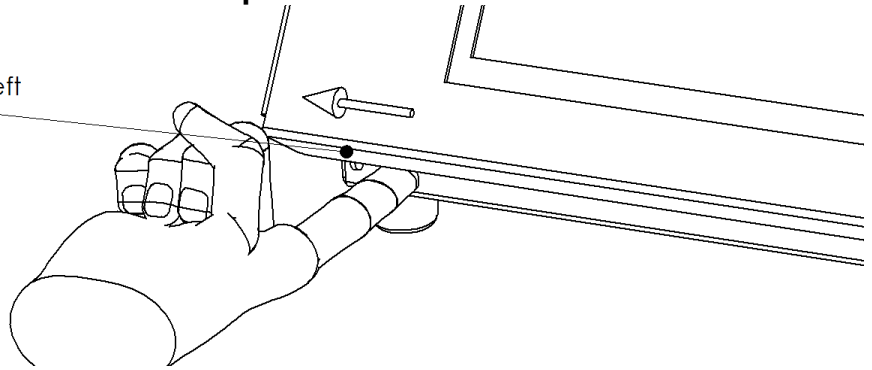

TERMINAL INSTALLATION
EXPLODED VIEW SHOWN FOR CLARITY.
PRODUCT SHIPS FULLY ASSEMBLED

Partner Tech EM-200 Two Screen Enclosed Countertop Mount PN 80921

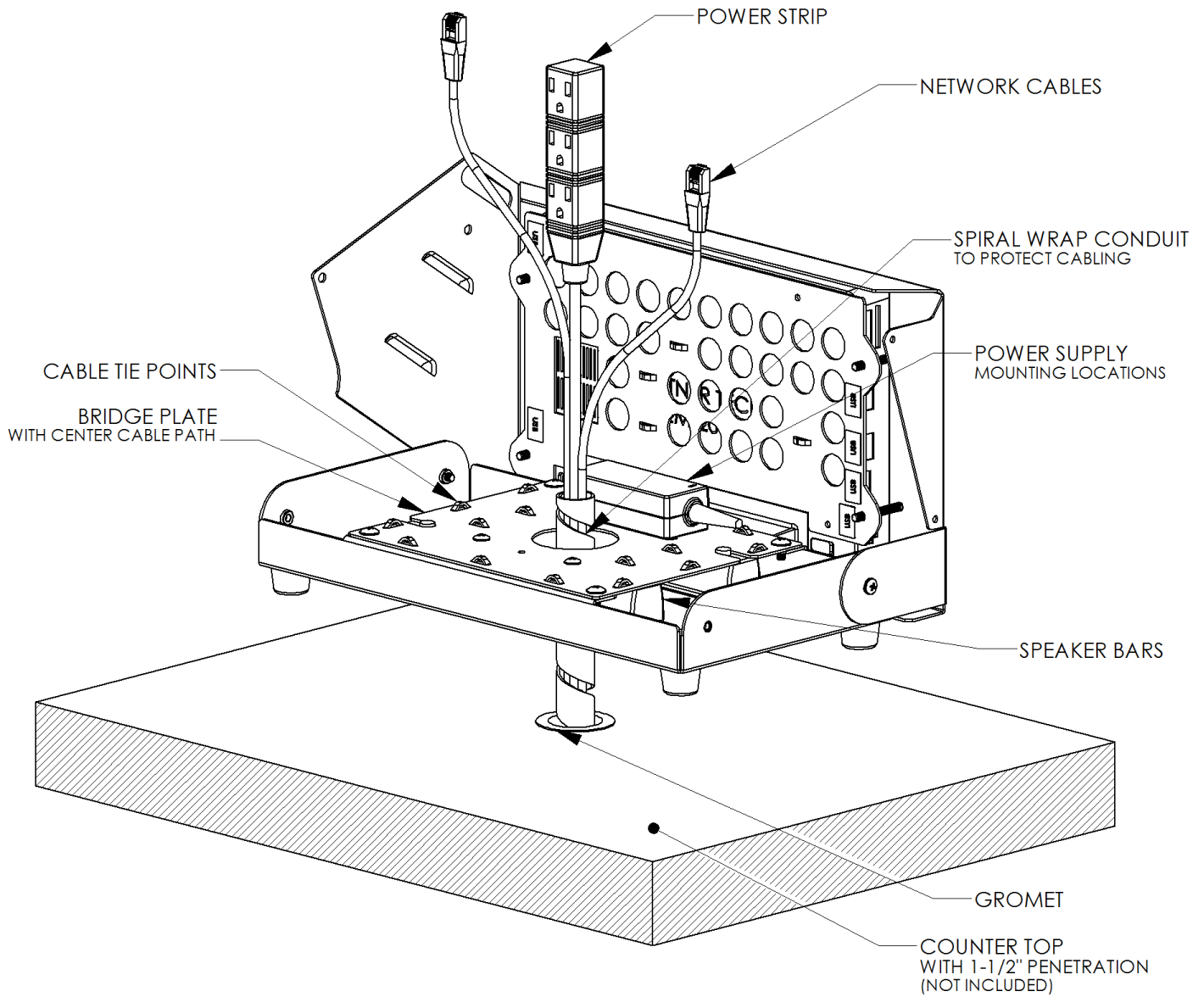

DATA AND POWER CABLE ROUTING

**NOTE: ONE COVER PLATE AND TOP COVER
HIDDEN TO SHOW INTERNAL DETAILS**

Partner Tech EM-200 Two Screen Enclosed Countertop Mount PN 80921

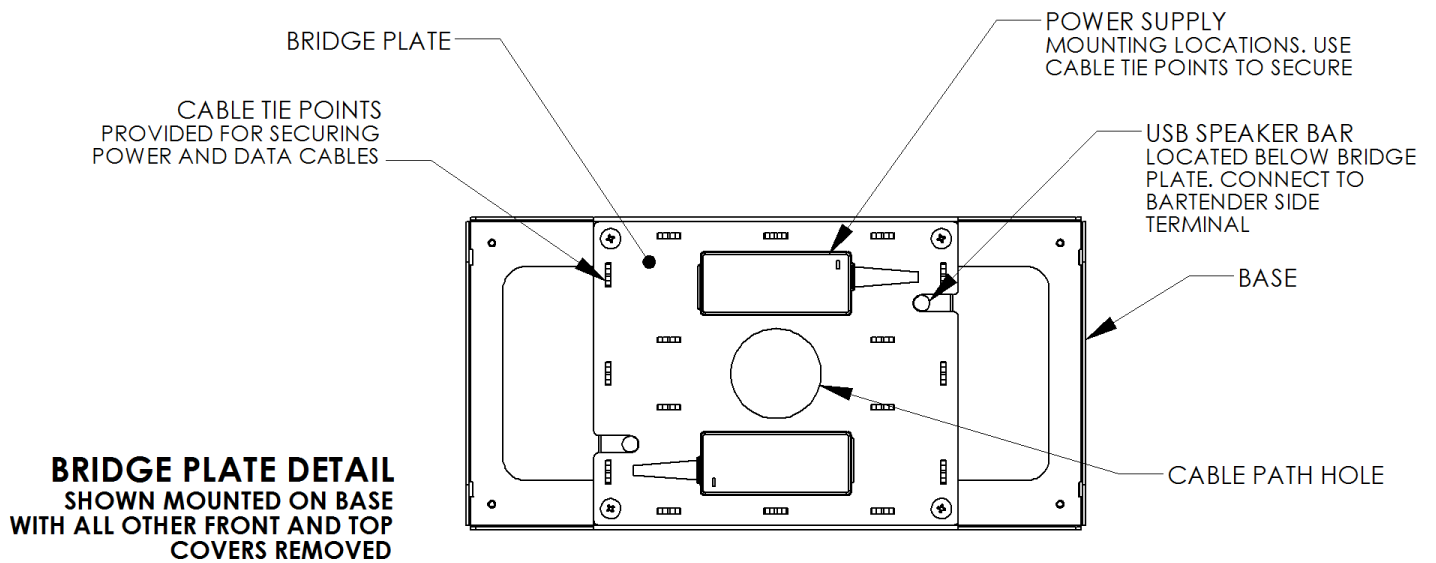
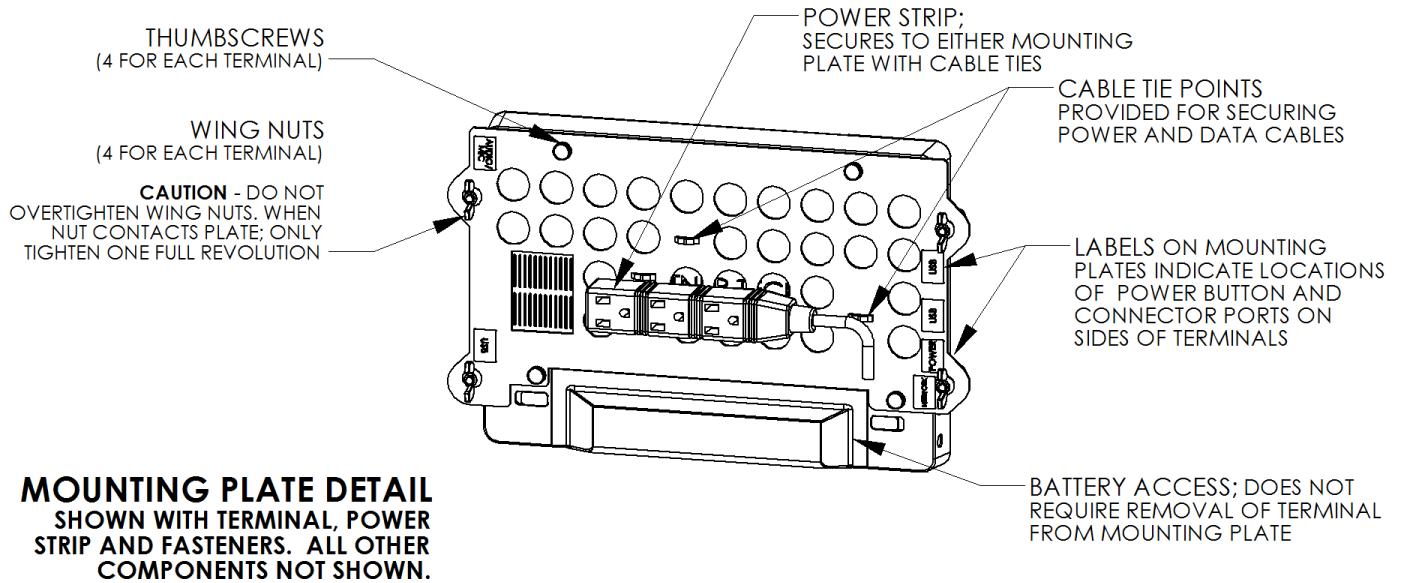

Partner Tech EM-200 Two Screen Enclosed Countertop Mount PN 80921

MOUNTING OPTIONS

- Mounting options for Partner Tech EM-200 touch screen monitors also include a *Wall Mount with Storage Compartment* (PN 80916), *Custom Fit Flat Mount* (PN 80919), *Single Countertop Mount* (PN 80915), *Multi Screen Flat Mount Bar* (PN 60126) or as a *Custom Fit* pan and tilt head by itself (PN 80880-401).

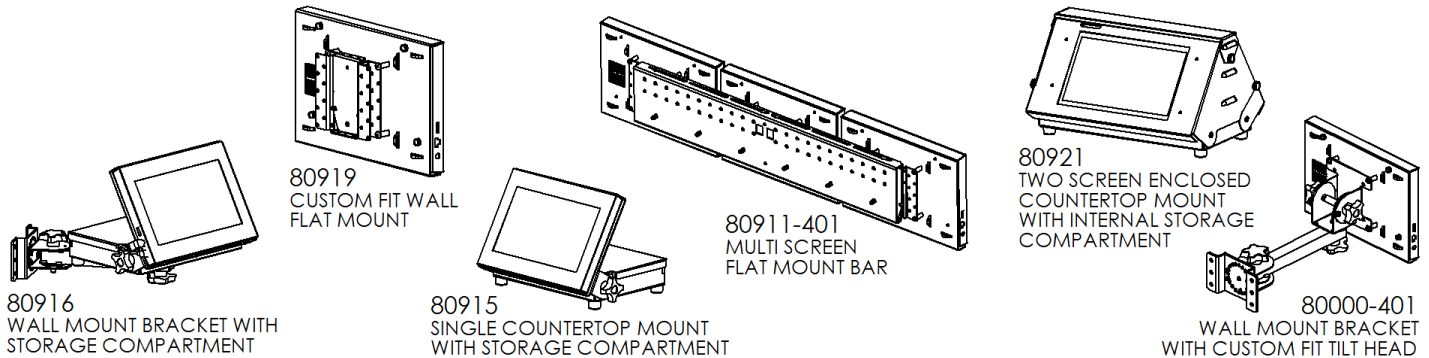

- All of our screen pan and tilt heads can be used with any of the following mounting systems.

