

PQS

PRACTICAL QUALITY SYSTEMS
Fast Custom Manufacturing - Nationwide Installation Services

Custom Fit Wall Flat Mount for Partner Tech EM200 PN 80919



NOTE: 80919 shown with Partner Tech EM200 Monitor. All mounting systems are also available for NON VESA compatible screens.

Custom Fit Wall Flat Mount for Partner Tech EM200 PN 80919

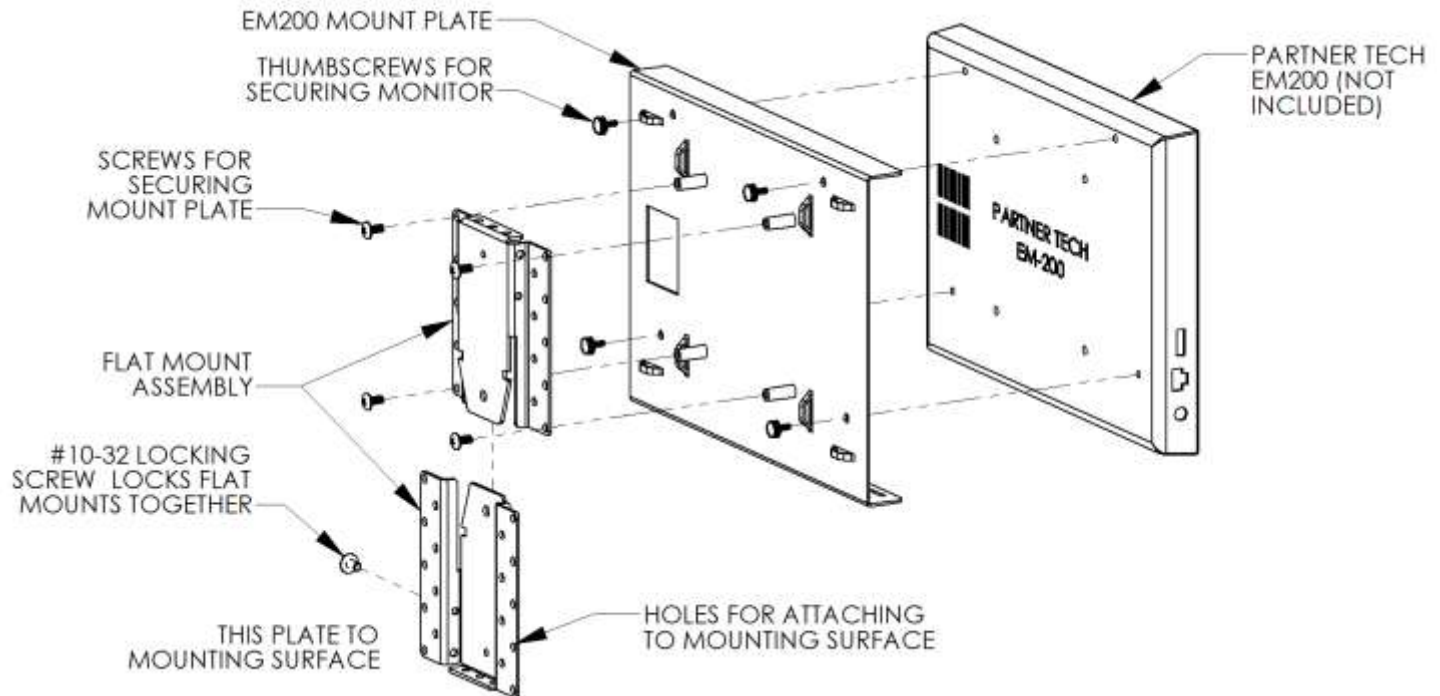

NOTE: 80919 Partner Tech EM200 touch screen.

PRODUCT SPECIFICATIONS

- Supports a Partner Tech EM200 touch screen monitor.
- Attaches to a wall or any other flat vertical surface.
- Thumbscrews are used to secure the monitor to the *EM200 Mount Plate*.
- 10-32 screws secure brackets in place at locking screw locations.
- Tie points found on the *EM200 Mount Plate* can be used to secure data and power cables.
- Both *Flat Mounts* are identical and interchangeable. Either one can be attached to the *EM200 Mount Plate* and/or attached to the mounting surface.
- For assembly instructions see the *User Manual* which can be downloaded from the *Product Resources* page on our website.
- Most of our modular mounting systems can be easily reconfigured in the field for a different application by either adding or removing a few parts to create a support solution for any mounting location.
- To order this assembly use part number 80919.
- To order this assembly in a 75/100mm VESA compatible configuration use part number 80910 and/or 80910-SS.
- For a list of additional non VESA compatible mounts and pan and tilt heads refer to the *Custom Fit Pan and Tilt Heads* page on our website found in the *Other Products* section. If we don't have a compatible mount or pan and tilt head; send us a sample of your screen and we'll create a *Custom Fit* solution for you.

Custom Fit Wall Flat Mount for Partner Tech EM200 PN 80919

MOUNTING OPTIONS:

- Mounting options for Partner Tech EM-200 touch screen monitors also include a *Wall Mount with Storage Compartment* (PN 80916), *Custom Fit Flat Mount* (PN 80919), single (PN 80915) and double sided (PN 80918) *Countertop Mounts*, *Multi Screen Flat Mount Bar* (PN 60126), or as just the *Custom Fit* pan and tilt head by itself (PN 80880-401).

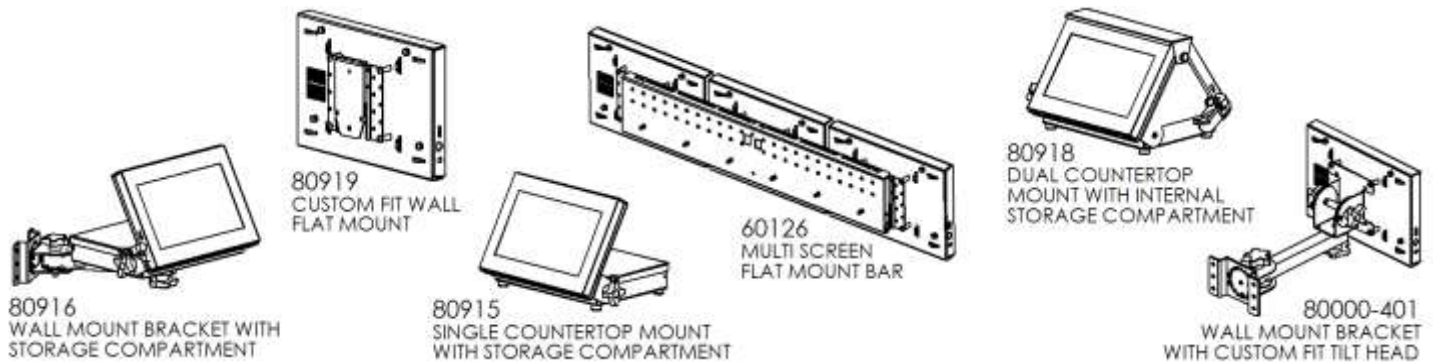

- PQS also offers a *Multi Screen Flat Mount Bar* (PN 60126) for mounting up to 3 Partner Tech EM200 monitors.

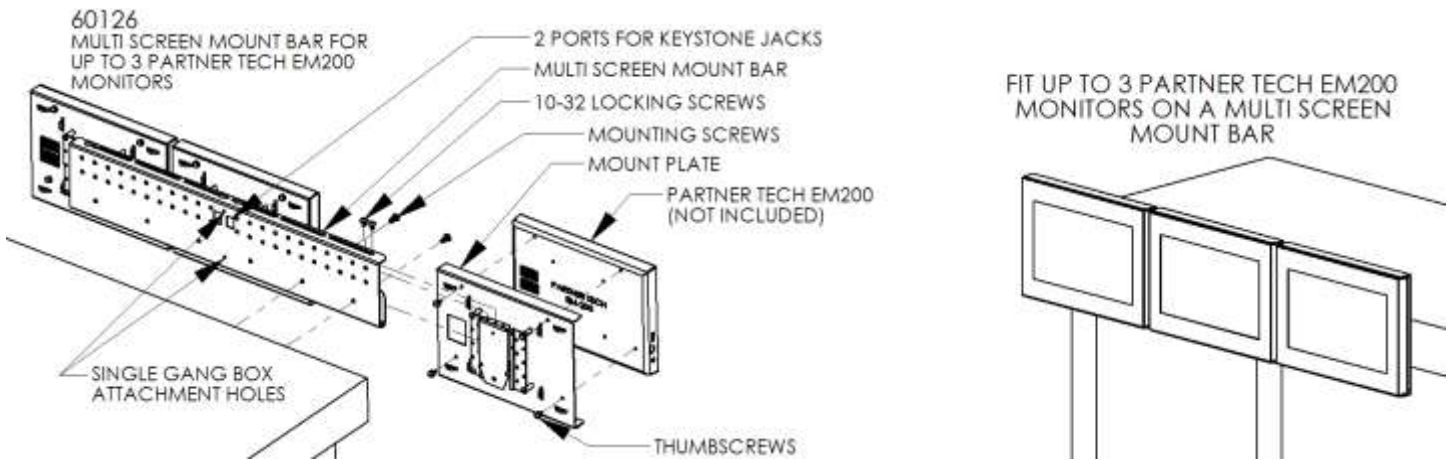

Custom Fit Wall Flat Mount for Partner Tech EM200 PN 80919

- PQS products are available to support all VESA and NON VESA compatible touch screens, terminals or flat panel monitors. Refer to the *Custom Fit Pan and Tilt Heads* page on our website found in the *Other Products* section for the most current list of options. If we don't have a compatible mount or pan and tilt head; send us a sample of your screen and we'll create a *Custom Fit* solution for you.

