

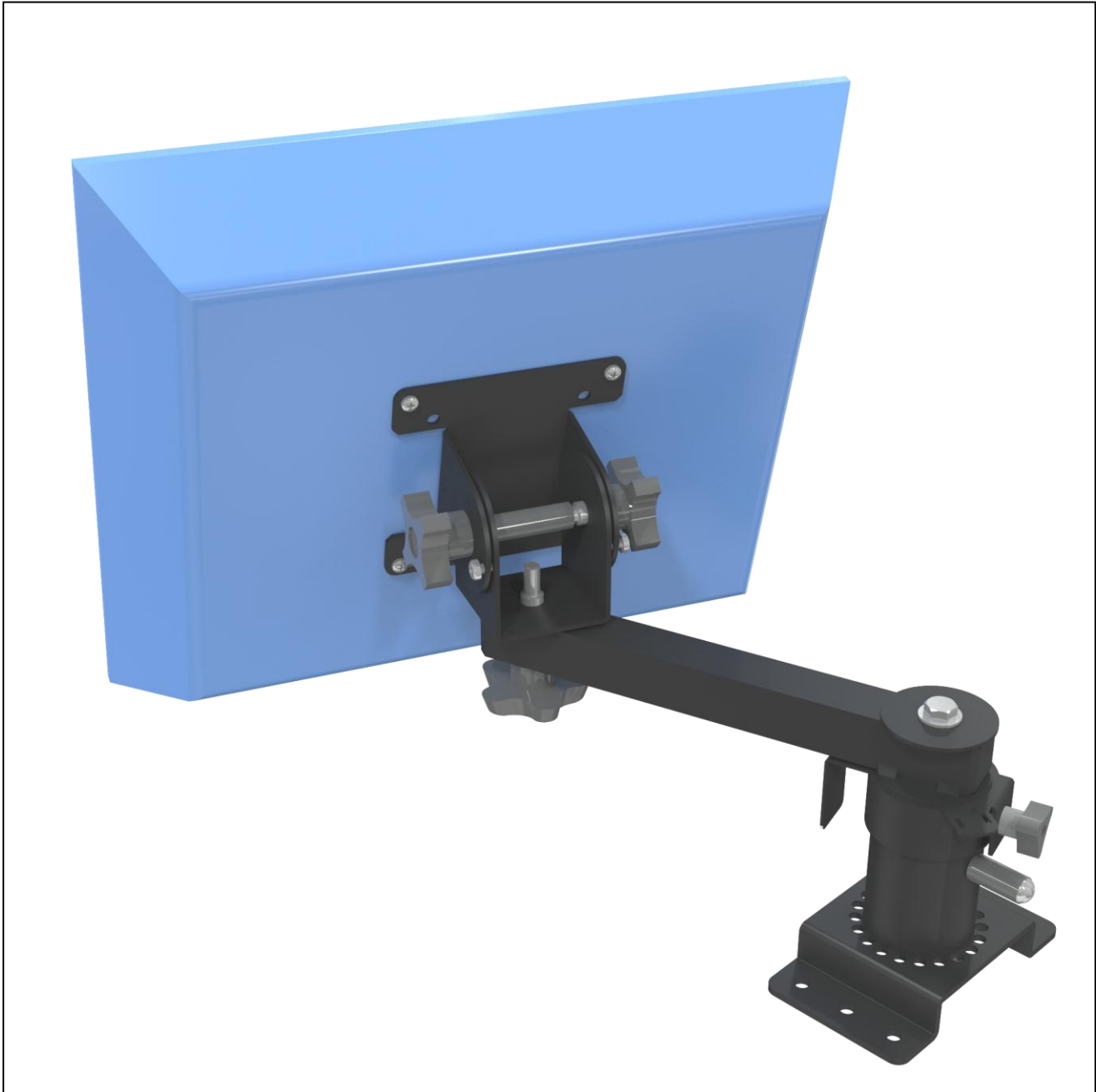

PRACTICAL QUALITY SYSTEMS
Fast Custom Manufacturing - Nationwide Installation Services

Pedestal Mount w/ 3" or 6" riser, 8" arm and a screen pan and tilt head PN 80080-80081



NOTE: 80081 with a 3" riser and a 75/100mm VESA Pan and Tilt head shown. All mounting systems are also available for NON VESA compatible screens.

info@practicalqualitysystems.com

WWW.PRACTICALQUALITYSYSTEMS.COM

(818) 993-1022

ALL PRODUCTS PATENT PENDING

Pedestal Mount w/ 3" or 6" riser, 8" arm and a screen pan and tilt head PN 80080-80081

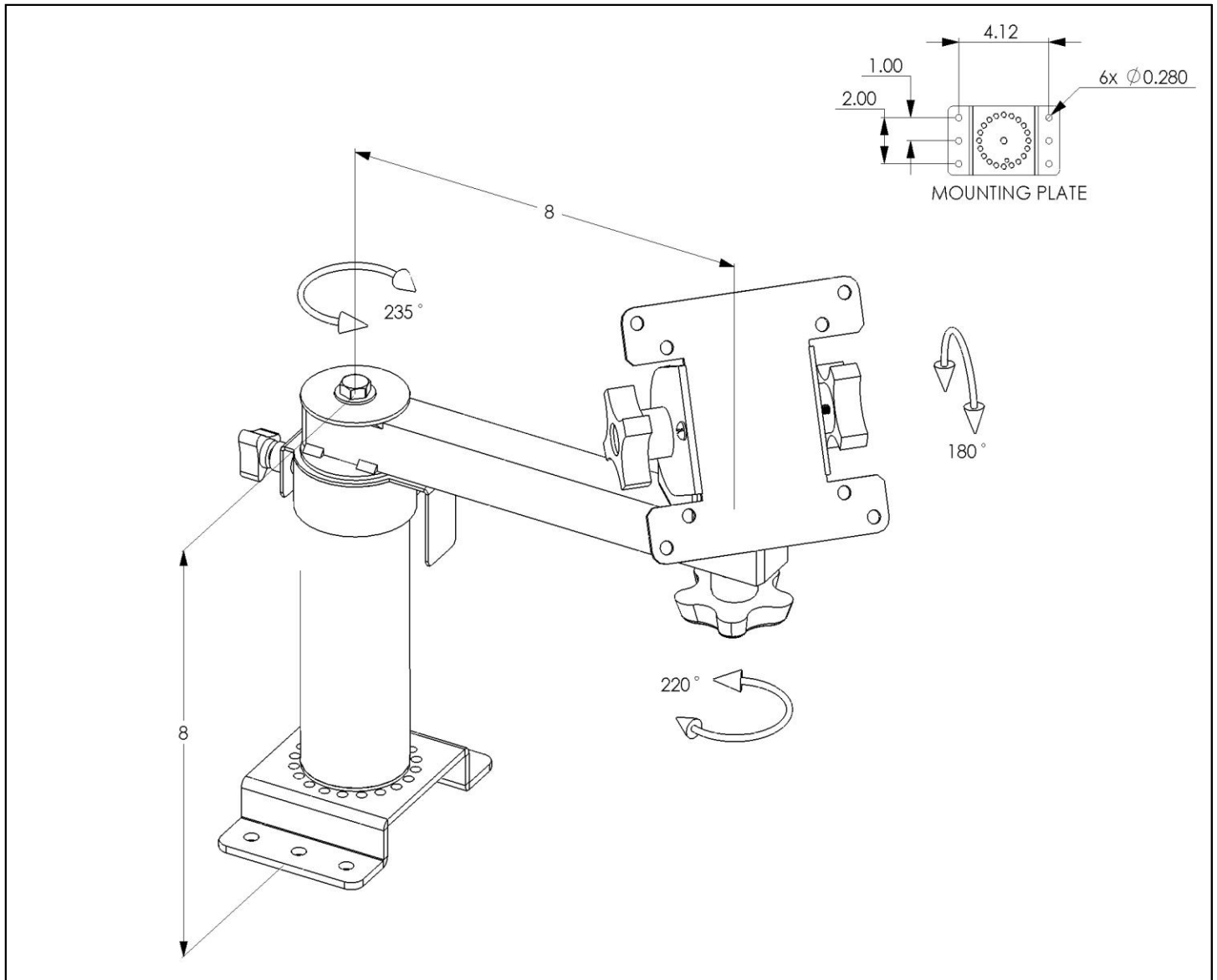

NOTE: 80080 with a 6" riser and a 75/100mm VESA pan and tilt head shown. All assemblies with NON VESA compatible pan and tilt heads will appear differently.

PRODUCT SPECIFICATIONS

- Available with pan and tilt heads to support all VESA and NON VESA compatible touch screens, terminals or flat panel monitors. Refer to the *Custom Fit Pan and Tilt Heads* page on our website found in the *Other Products* section for the most current list of options. If we don't have a compatible pan and tilt head send us a sample of your screen and we'll create a *Custom Fit* solution for you.
- The assembly supports touch screens, terminals or flat panel monitors up to 20" (all images are shown with a 17" screen).
- Attaches to a counter top, shelf or any other flat horizontal surface.

info@practicalqualitysystems.com

WWW.PRACTICALQUALITYSYSTEMS.COM

(818) 993-1022

ALL PRODUCTS PATENT PENDING

Pedestal Mount w/ 3” or 6” riser, 8” arm and a screen pan and tilt head PN 80080-80081

- Pan and Tilt Head adjusts without tools to lock the screen at any position, side to side, or up and down.
- In some cases it is recommended to install a screen on a 6 inch riser and printer on a 3 inch riser.
- A 3” or 6” riser elevates the 8” arm above the mounting surface and permits the pan and tilt head to travel horizontally to allow a wide range of screen locations.
- The position of the screen pan and tilt head can also be locked more securely for the long term by tightening locking screws on the pan and tilt head with a Phillips screw driver.
- Add an optional *three arm mounting plate*, a riser, and an arm with a *Universal Printer Mounting Tray* to support a printer right next to the terminal.
- The arms can rotate freely or be locked in any position horizontally without tools at the riser cap.
- The screen pan and tilt head or printer can be easily removed from the arm and attached directly to the top of the riser.
- The riser cap incorporates a cable tie point to secure the cables so that they will travel safely as the arm is rotated.
- Integral stop details on the riser and arm can be located at any setting to prevent cable damage when the arm supporting the screen or the printer is rotated around the riser.
- Most of our modular mounting systems can be easily reconfigured in the field for a different application by either adding or removing a few parts to create a support solution for any mounting location.
- Please specify either 3" or 6" riser(s) when ordering.
- Each arm supports up to 15 lbs.
- For assembly instructions see the *User Manual* which can be downloaded from the *Product Resources* page on our website.

PRODUCT ASSEMBLIES

See descriptions for the different product assemblies below to determine which best suites your needs. For NON VESA compatible pan and tilt heads add the part number suffix found on the *Custom Fit Pan and Tilt Heads* page on our website. The page can be found listed under the “Other Products” section.

- 6” riser plus:
 - 75/100mm VESA compatible pan and tilt head 80080
 - *Custom Fit* NON VESA compatible pan & tilt head 80080 + Suffix
- 3” riser
 - 75/100mm VESA compatible pan and tilt head 80081
 - *Custom Fit* NON VESA compatible pan & tilt head 80081 + Suffix

If the website doesn’t show a suffix that represents your compatible pan and tilt head then send us a sample of your screen and we’ll create a *Custom Fit* solution for you.

Pedestal Mount w/ 3” or 6” riser, 8” arm and a screen pan and tilt head PN 80080-80081

info@practicalqualitysystems.com

WWW.PRACTICALQUALITYSYSTEMS.COM

(818) 993-1022

ALL PRODUCTS PATENT PENDING

- All of our screen pan and tilt heads can be used with any of the following mounting systems.

