

PQS

PRACTICAL QUALITY SYSTEMS
Fast Custom Manufacturing - Nationwide Installation Services

MODULAR SCREEN SHELF EDGE MOUNT PN 80912-SS

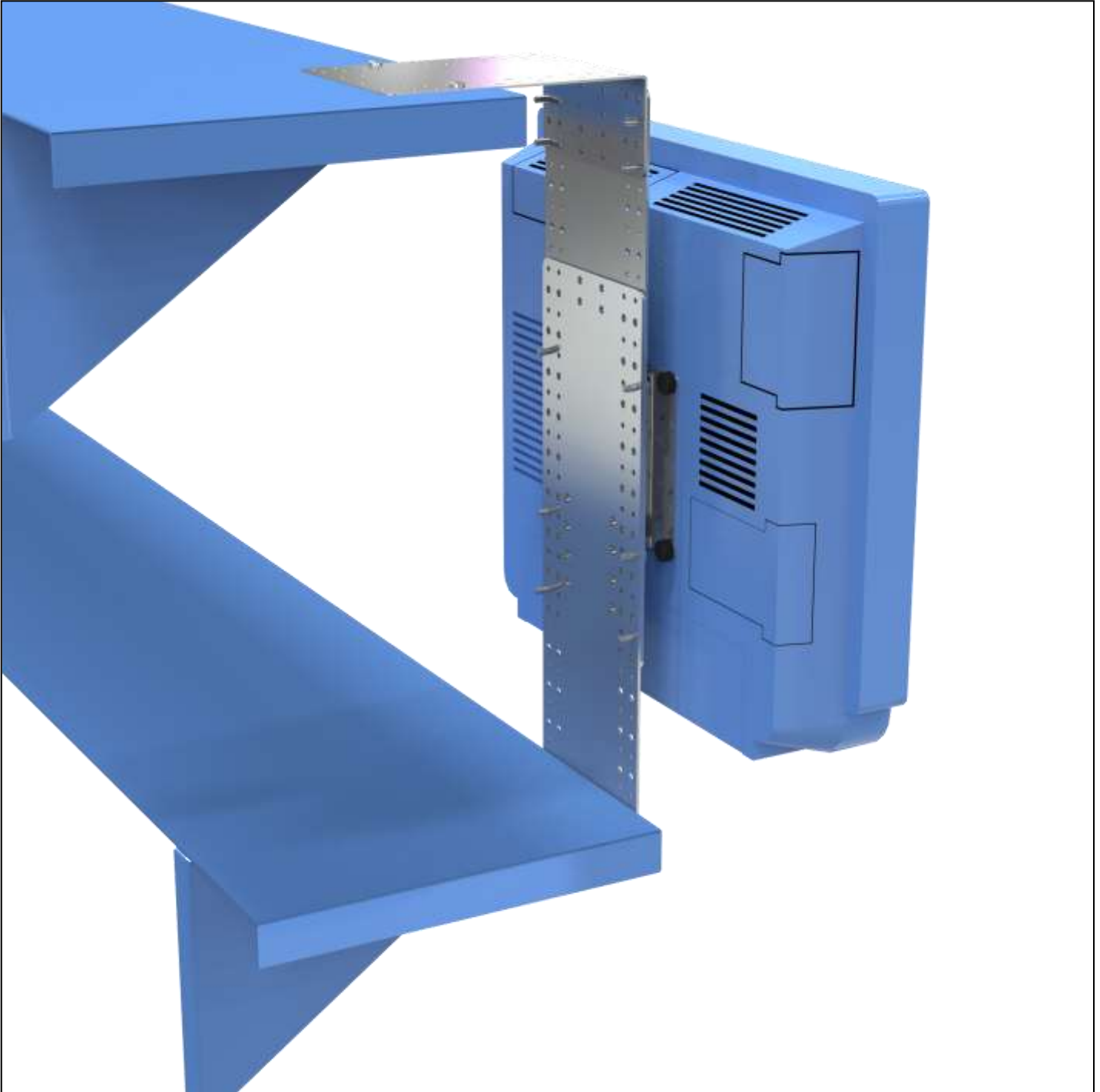

NOTE: 80912-SS shown with IBM 4838 15" monitor

info@practicalqualitysystems.com

WWW.PRACTICALQUALITYSYSTEMS.COM

(818) 993-1022

ALL PRODUCTS PATENT PENDING

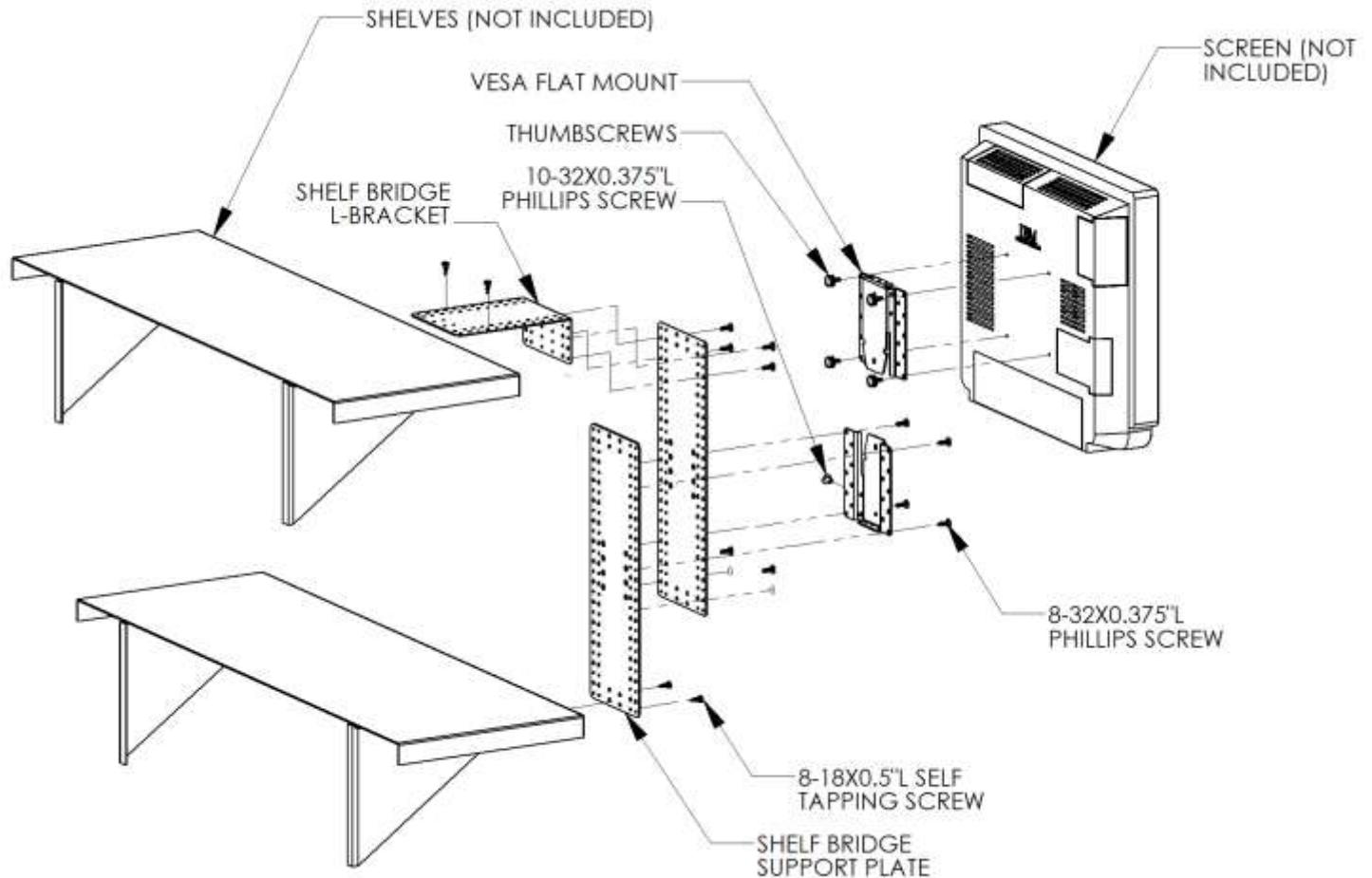
MODULAR SCREEN SHELF EDGE MOUNT PN 80912-SS

NOTE: *Shelf Edge Mount* PN 80912-211 bridging offset shelves, shown with IBM-4838 15" monitor.

PRODUCT SPECIFICATIONS:

- Supports a single 75/100mm VESA compatible touch screen, terminal or flat panel monitor up to 24" for mounting between shelves.
- A *Shelf Bridge L Bracket* can be used to create an offset mounting bridge wherever two shelves are found to be of different depths up to 5".
- *Shelf Bridge Support*, *Shelf Bridge L Bracket*, *Flat Mount Bracket* and all hardware is made of corrosion resistant stainless steel.
- Screen locations can be moved side to side after installation. No welding needed.
- The height of the screen can be adjusted with only a screwdriver.
- Screens are attached with thumbscrews for easy removal.
- Two identical and interchangeable *Shelf Bridge Support Plates* can be used together in a stacked configuration to create an adjustable "bridge" across two shelves that can be lengthened as needed to a span of up to 20".
- A single Bridge Support Plate is 13-1/4". The maximum span of two plates put together is approximately 24-1/2".
- 10-32 screws secure brackets in place at locking screw locations.

MODULAR SCREEN SHELF EDGE MOUNT PN 80912-SS

PRODUCT ASSEMBLIES

- For assembly instructions see the *User Manual* which can be downloaded from the *Product Resources* page on our website.

MOUNTING OPTIONS:

- All mounting systems can be mounted with any of the following mounting systems and are available with *Custom Fit Tilt* heads or mounting hole patterns for all non VESA compatible screens. Refer to the *Custom Fit Tilt Head* page on our website for a current list of all non VESA compatible tilt heads. The page can be found listed under the *Other Products* section. If we don't have a compatible pan and tilt head send us a sample of your screen and we'll create a *Custom Fit* solution for you.

