

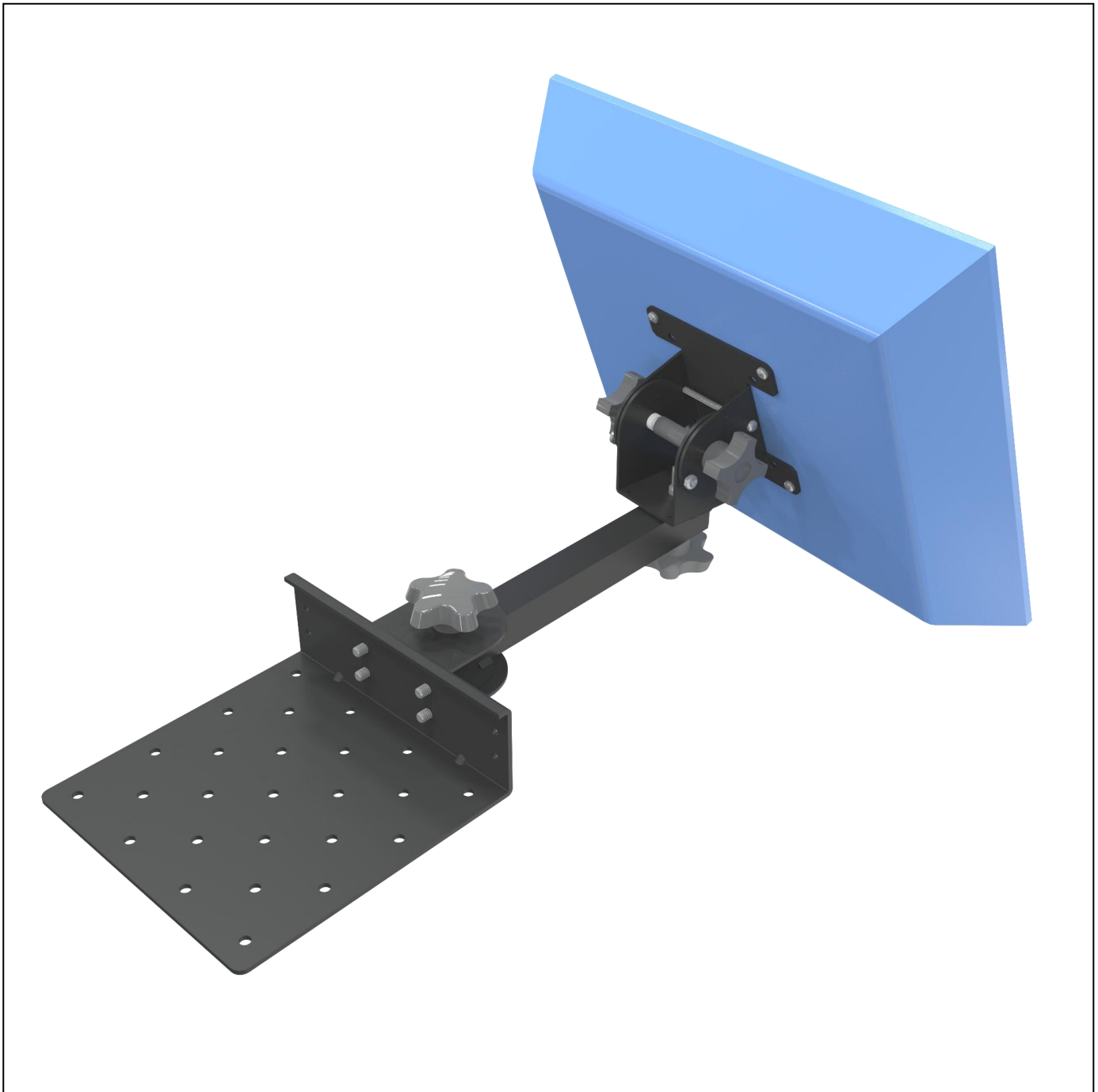

PRACTICAL QUALITY SYSTEMS
Fast Custom Manufacturing - Nationwide Installation Services

Under Counter Mount w/ 8" arm, and a screen pan and tilt head PN 80200



NOTE: 80200 with a 75/100mm VESA Pan and Tilt head shown. All mounting systems are also available for NON VESA compatible screens.

Under Counter Mount w/ 8" arm, and a screen pan and tilt head PN 80200

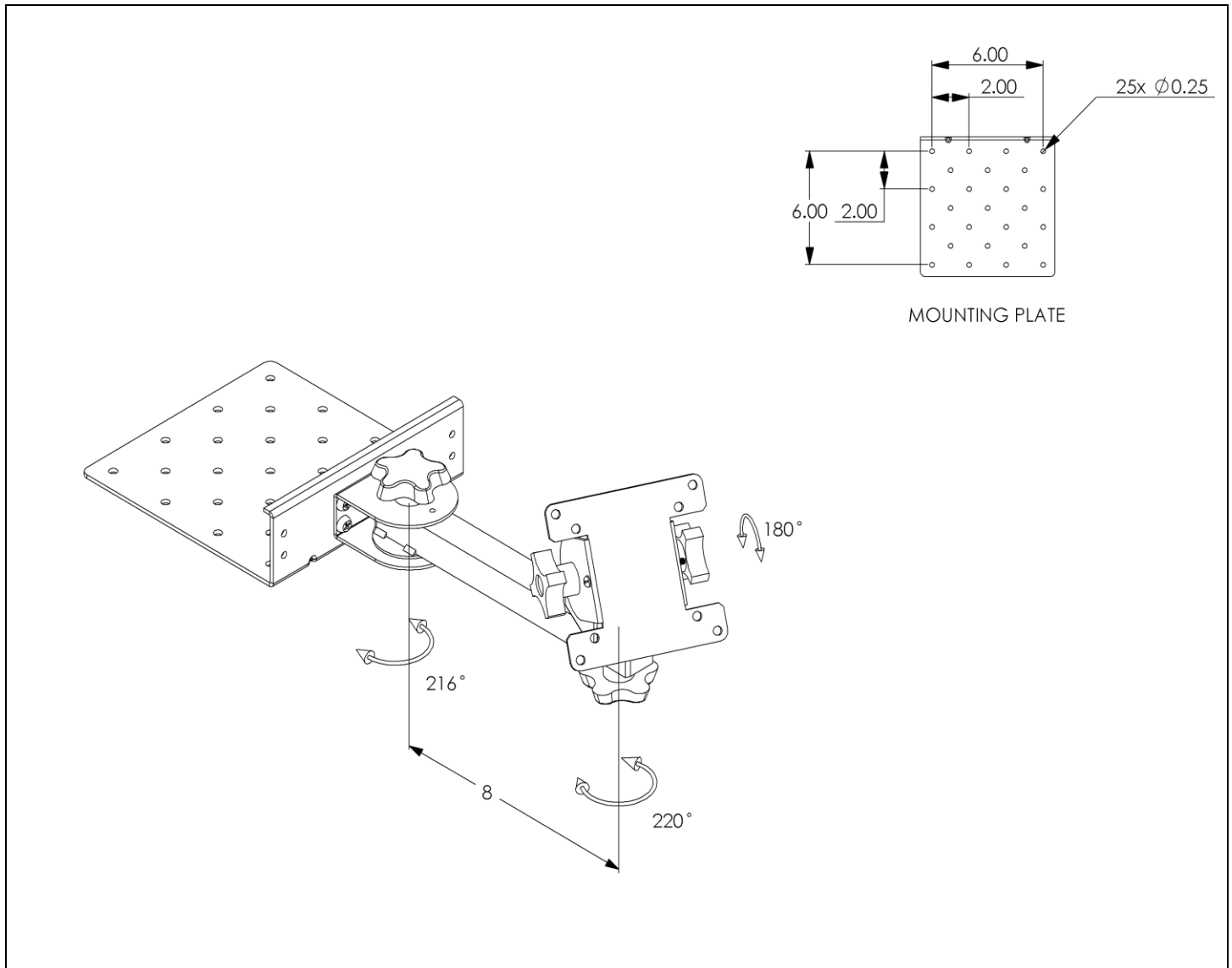

NOTE: 80200 with a 75/100mm VESA pan and tilt head shown. All assemblies with NON VESA compatible pan and tilt heads will appear differently.

PRODUCT SPECIFICATIONS

- Available with pan and tilt heads to support all VESA and NON VESA compatible touch screens, terminals or flat panel monitors. Refer to the *Custom Fit Pan and Tilt Heads* page on our website found in the *Other Products* section for the most current list of options. If we don't have a compatible pan and tilt head send us a sample of your screen and we'll create a *Custom Fit* solution for you.
- Attaches underneath a counter top, a shelf or any other flat horizontal surface.
- Pan and tilt head adjusts without tools to lock the screen at any position, side to side, or up and down.

Under Counter Mount w/ 8" arm, and a screen pan and tilt head PN 80200

- The position of the 8" arm adjusts without tools and permits the pan and tilt head to travel horizontally to allow a wide range of screen locations.
- The position of the arm can be locked more securely for the long term by tightening the arm locking screw with a Phillips screw driver.
- The *Under Counter* mounting plate permits attachment of a second optional arm and a *Universal Printer Mounting Tray* to support a printer right next to the terminal.
- This assembly is one of our modular mounting systems. This system includes many components which can be mixed and matched to create a custom support solution for any mounting location. Most of our modular mounting system assemblies can be easily reconfigured in the field for a different application by either adding or removing a few parts.
- Each arm supports up to 15 lbs.
- For assembly instructions see the *User Manual* which can be downloaded from the *Product Resources* page or from the info sheet on our website.
- To order this assembly use part number 80200.
- To order this assembly with a *Custom Fit*, NON VESA compatible screen tilt head; use part number 80200 and add the part number suffix found on the *Custom Fit Pan and Tilt Heads* page on our website. The page can be found listed under the *Other Products* section. If the website doesn't show a suffix that represents a type that is compatible with your screen pan and tilt head send us a sample of your screen and we'll create a *Custom Fit* solution for you.

Under Counter Mount w/ 8" arm, and a screen pan and tilt head PN 80200

MOUNTING OPTIONS:

- All of our screen pan and tilt heads can be used with any of the following mounting systems.

