

# PQS

PRACTICAL QUALITY SYSTEMS

*Fast Custom Manufacturing - Nationwide Installation Services*

UVHM-UC-VESA-UPMT

PN 80203

A two position under counter mounting plate with two 8" arms, a VESA tilt head and a universal printer mounting tray

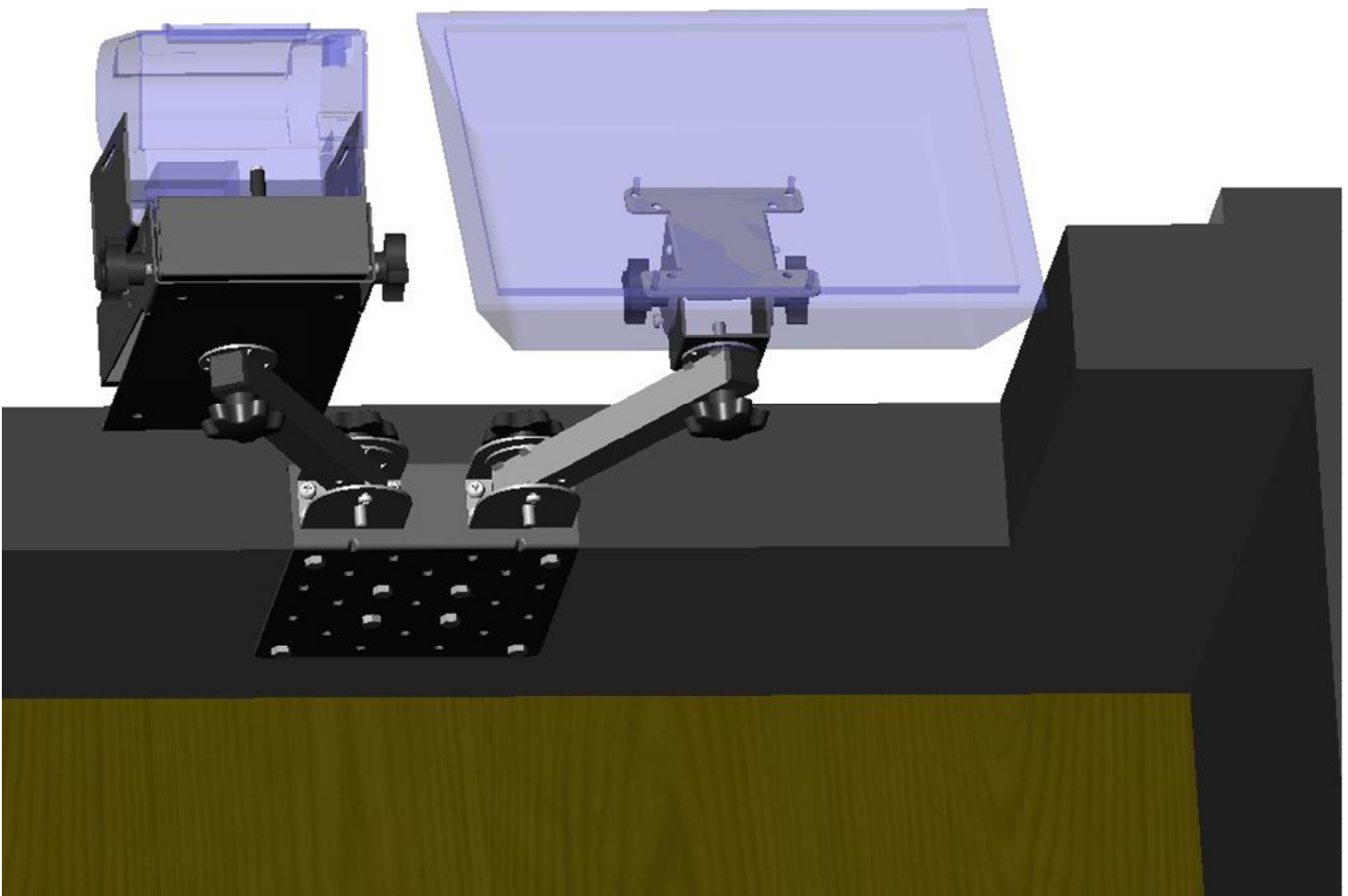

**A two position under counter mounting plate with two 8" arms, a VESA tilt head and a universal printer mounting tray**

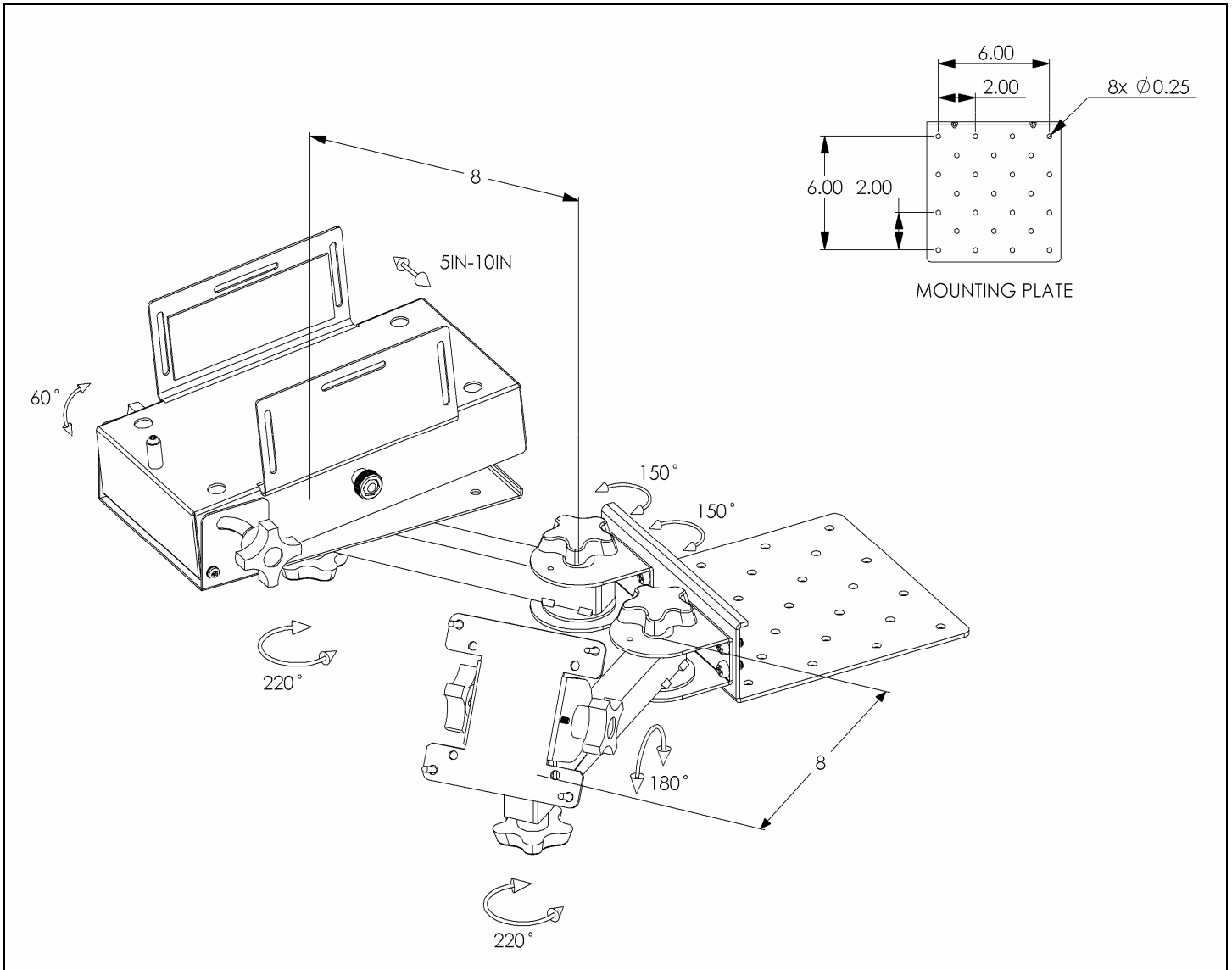

**A two position under counter mounting plate with two 8” arms, a VESA tilt head and a universal printer mounting tray**

## PRODUCT SPECIFICATIONS

- Supports a Micros WS5 terminal or any 75 or 100 mm VESA compatible touch screen, terminal or flat panel monitor and a printer.
- The assembly supports touch screens, terminals or flat panel monitors up to 20” (all images are shown with a 17” screen).
- Attaches underneath of a counter top, a shelf or any other flat horizontal surface.
- VESA tilt head adjusts without tools to lock the screen at any position, side to side, or up and down.
- The position of the tilt head can be locked more securely for the long term by tightening the tilt head locking screws with a Phillips screw driver.
- The sides of the printer tray adjust without tools to grip the sides of any printer from 5” to 9 ½” wide.
- The printer tray can be tilted forward, rotated and locked into position without tools.
- The positions of the 8” arms adjust without tools to permit the printer tray and tilt head to travel horizontally, allowing a range of positioning options.
- The position of the arm can also be locked more securely for the long term by tightening the arm locking screw with a Phillips screw driver.
- The UPMT also makes a great telephone mount.
- This assembly is part of the UVHM system which includes many components that can be mixed and matched to create a support solution for any mounting location. Most of the UVHM assemblies can be easily reconfigured in the field for a different application by either adding or deleting a few parts.
- Each arm supports up to 15 lbs.