

PQS

PRACTICAL QUALITY SYSTEMS
Fast Custom Manufacturing - Nationwide Installation Services

Work Table 45"W with a Lower Shelf and 2 Upper Shelves PN 81250

Includes a 45"W X 30"D Stainless steel table top assembly, 2- Side Support assemblies w/ 4- Leveling Legs, a 44.75"W X 14"D galvanized lower shelf assembly, a Lower Back Panel, an Upper Shelving System with 2- 64"H Vertical Shelf Standards, 2-Stainless steel topped 44.75"W X 14"D shelves, 4- Shelf Brackets and a hardware kit.



Need it installed? We have nationwide professional installation services available. Just contact us!

info@practicalqualitysystems.com

WWW.PRACTICALQUALITYSYSTEMS.COM

(818) 993-1022

ALL PRODUCTS PATENT PENDING

Introduction for all Work Tables

We currently manufacture two basic sizes of Work Tables; both are 30" deep and 30" tall and are available in widths of 45" and 72". Our Work Tables are constructed entirely of stainless and galvanized steel to resist corrosion and harsh environments. Designed to be extra strong; these tables are engineered with three interior structural support beams under the table top which is further reinforced with welded corners.

For the ultimate indestructible work surface, add the optional ¼" thick vinyl Table Top Protector. For 45" wide Work Tables order PN 50304, for 72" W Work Tables order PN 50305

Value is added across our entire line of Enclosures, Work Tables and Shelving Systems because they all have been designed to be modular and to be compatible with a wide range of optional equipment. These features insure maximum flexibility when integrating different components to render a custom solution.

Need more work space? Add a 30" wide Side Table PN 60089 to any 45" or 72" W Work Table.

All Work Tables can be configured with Caster Wheels or they can be Wall mounted.

All of our Enclosures and Work Tables can be bolted together side to side, corner to corner or back to back to create a large variety of customized configurations to fit your space.

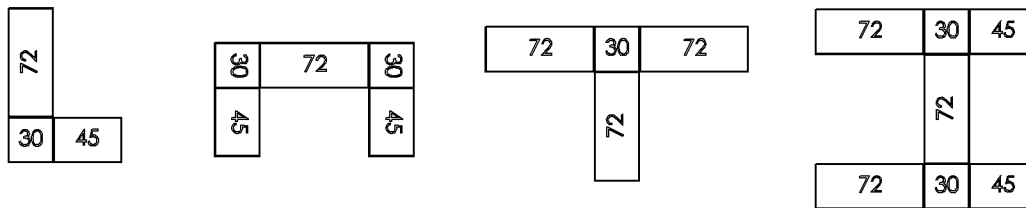

CONFIGURATION EXAMPLES

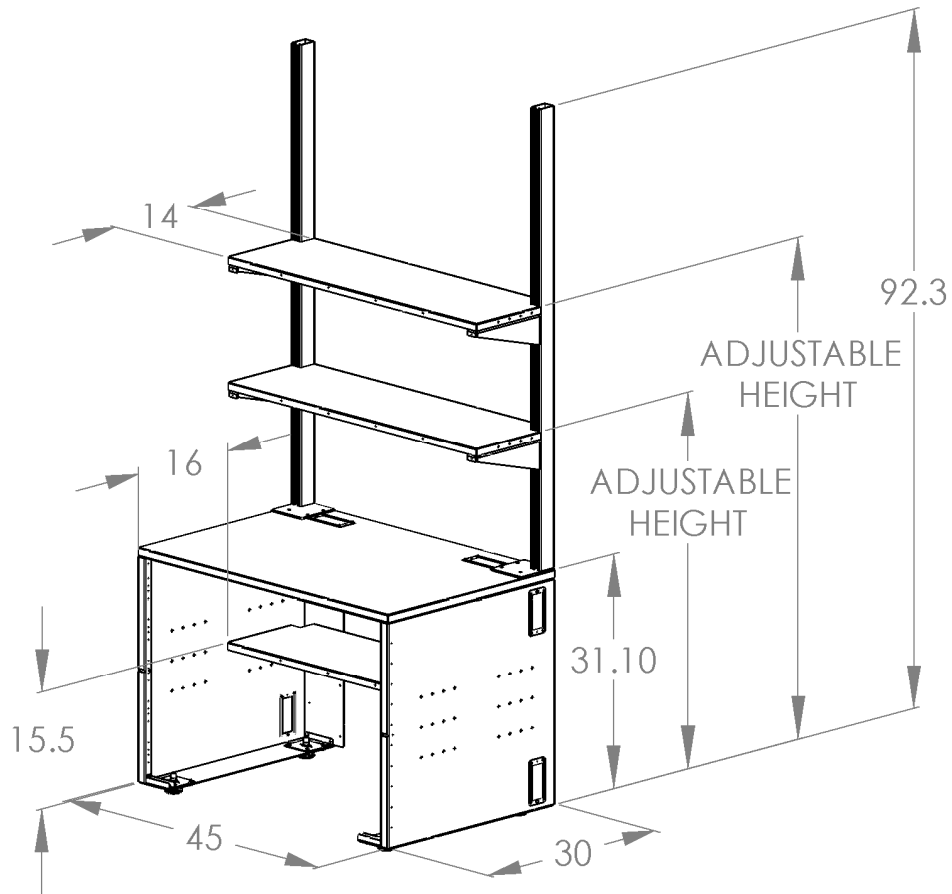
Product Specifications**General Measurements:** 45" W x 92"H x 30"D**Weight:**

45 W Work Table w/ Upper Shelving Bare = 243 lbs. Note: This weight does not include any options or accessories. Each Work Table will probably contain at least 50 lbs. of accessories.

Dimension Notes:

Refer to engineering drawings for exact dimensions. Please be advised some external assemblies may not be shown in all images.

Engineering Drawing Reference Notes

To view and manipulate 3D models of any assembly; visit www.edrawingsviewer.com and download the free eDrawings viewer software, then open the eDrawing format files (.EASM) found in our Engineering Drawings folders.

For more product dimensional specifications; download the Engineering Drawings folder for files in DWG, PDF and EASM formats on our website from the tool bar on the individual product pages or from our Product Resources page.

User Manual Reference

Refer to manual 10010401-UM for assembly and installation instructions

User manuals are available for download in PDF format on our website from the tool bar on the individual product pages or from our Product Resources page.

Standard Features:**45" wide Work Table Cable Path Openings**

All 45" wide Work Tables feature six large and convenient Cable Path Openings that are fully adjustable to make the installation of cabling and power cords quick and easy. There are two openings near the left and right corners of the rear of the Table Top and two openings near the bottom rear corners of both the left and right side support assemblies.

Heavy Duty Table top is pre machined for attaching options

The table top is made of heavy 16 Gauge Stainless Steel with welded corners. It has been pre marked with small indentations that mark the locations of the 5/16" holes that are needed for adding optional Vertical Shelf Standards to support shelves or an Upper Cabinet.

Side Support assemblies

The Side Supports are designed with integral support pillars for added strength. Each is engineered to be universal and can be configured to be installed either on the right or left side simply by changing where the Side Support Front Brace is attached. To relocate the Side Support Front Brace, remove the three screws that attach it to the Side Support, turn the Side Support upside down and reinstall the Front Brace. Each Side Support includes two adjustable cable paths. The back section where the supports meet the wall has been pre punched with a series of holes to make simple to attach the Side Supports to studs inside the wall that are spaced at the standard of 16" on center.

Lower Back Panel

The Lower Back Panels come in two widths: 45" wide (PN 50240) and 72" wide (PN 50268). The 72" wide Lower Back Panel allows Lower Cabinets to be installed on the right or left of a 72" wide assembly. The panel attaches to the Side Supports, the Lower Shelf, and the rear C-beam to enclose the entire lower rear of the assembly. It includes rows of mounting holes for attaching the panel to structural members which are 16" on center.

Insert Plates

There are four 1/4" thick steel "Insert Plates" installed in each of the four corners of the support beams in the Table top of all Work Tables and on side support assemblies. These plates create "hard points" that add extra strength for attachment of Side Supports, Leveling Legs, Caster Wheels or Shelving Systems.

Standard Features Continued:**Leveling Legs and Optional Caster Wheels**

All Work Tables feature adjustable Leveling Legs that allow quick and easy leveling on uneven surfaces. The foot of each leveling leg includes a movable mounting strap that swivels around the leg and permits simplified attachment to the mounting surface. If a mobile solution is desired, simply remove the Leveling Legs and add the optional Caster Wheel kit- PN 60103. These wheels are intended for temporary use and attach directly to the bottom of the Side Supports. They feature locking brake mechanisms and swivel a full 360 degrees to allow easy movement in any direction.

Included Options:**Lower Shelf for 45"W Work Tables**

Includes one Lower Shelf assembly with a galvanized steel top and Cable Path Openings at the left and right rear corners of the shelf. The shelf attaches between the Side Supports below the Enclosure and has three adjustable height positions. The top and bottom shelf positions create 18" tall spaces either above or below the shelf. The center shelf position creates two 14" tall spaces. Overall dimensions 44.75"W X 14"D. Add an optional Lower Galvanized Shelf Kit-PN 60039 to increase the depth of an existing half depth shelf from 14" shelf to 28" D.

Upper Shelving System 45" Wide

Includes an two galvanized Vertical Shelf Standards, two Stainless steel topped 45" W X 14"D shelf assemblies that feature two internal support beams, 4- Galvanized Shelf Brackets and a hardware kit.

List of all available options and accessories for Work Tables:

Select a preconfigured Work Table or use our line of Options and Accessories to create a customized solution that fits your exact needs.

Pull Out Work Surface

Full size File Drawers

Half Size Drawers (2)

All in One Drawer Set

Drawer Set with Combo Frame (3)

19" Rack Mount Drawer Kits for Lower Cabinets

Lock Bar Kits (2)

VESA Monitor and POS Printer Mounts for Enclosure interiors, Work Tables or Shelving Systems (4)

Cross bars for Shelving Systems for Monitor or Printer Mounts (3)

Bin Boxes (3)

Bin Box Mounting Bars for Bin Boxes for Shelving Systems (2)

Bin Box Mounting Bars for Enclosure interiors (3)

Shelving System 64" H for above Work Tables (2)

Additional Upper Shelf Kits (4)

Additional Lower Shelf Kits (2)

Side Table and Corner Junction

Wall Mount Kits for Enclosures and Work Tables (2)

Free Standing Kits for Counter Top Enclosures (2)

Caster Wheel Kit

Lower Cabinet Kits for Counter Top Enclosures (3)

Lower Cabinet Kits for Free Standing Enclosures or Work Tables (3)

Upper Cabinet Kits (2)

Fluorescent Strip Lights (2)

Multiple Outlet Power Strips 36"L (2)

Modular Ventilation Systems and Fans (2)

Table Top Protectors (2)