

PQS

PRACTICAL QUALITY SYSTEMS
Fast Custom Manufacturing - Nationwide Installation Services

Environmental Monitor Enclosure PN 80400-80401



Note: 80400 Environmental Enclosure for 17"-19" flat panel monitors shown. Also available for 20"-24" monitors.

info@practicalqualitysystems.com

WWW.PRACTICALQUALITYSYSTEMS.COM

(818) 993-1022

ALL PRODUCTS PATENT PENDING

Environmental Monitor Enclosure PN 80400-80401

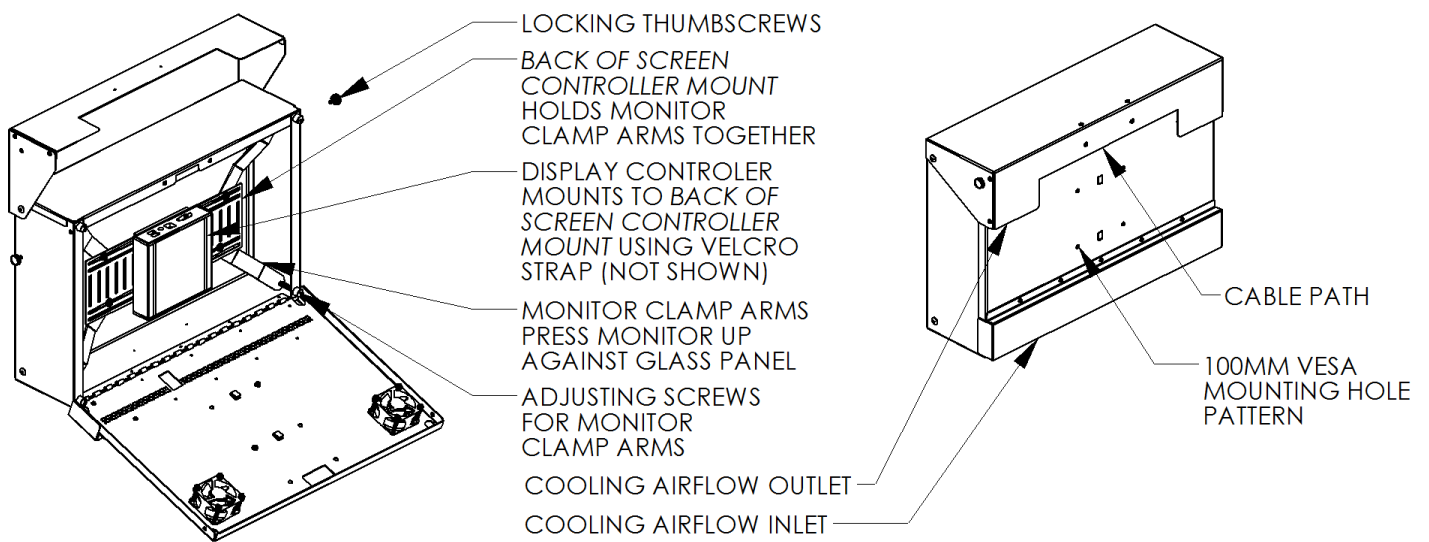
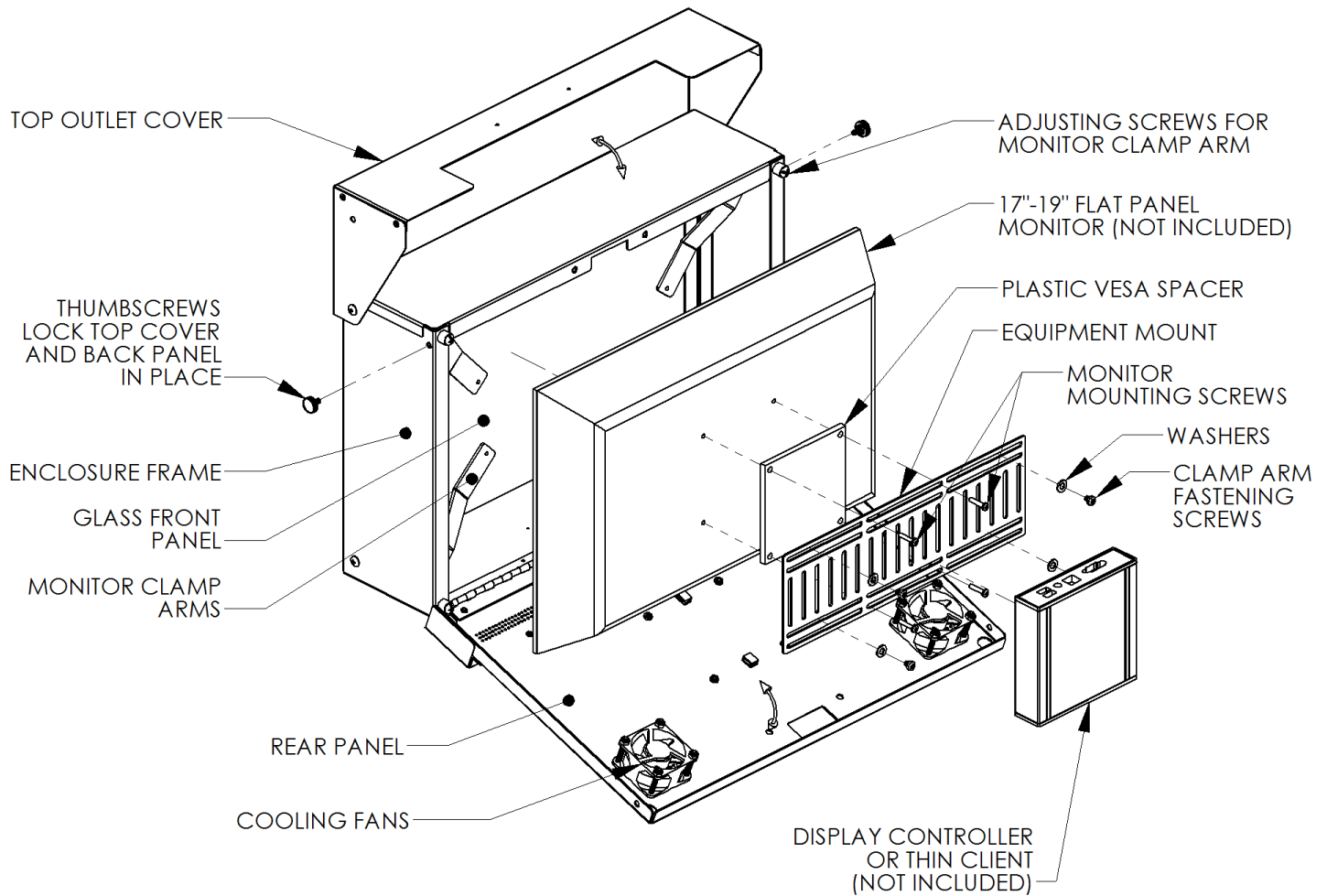

Environmental Monitor Enclosure PN 80400-80401

PRODUCT SPECIFICATIONS:

- *Environmental Monitor Enclosures (EME)* protects any flat screen monitor 17"-24," with either a 75mm or 100mm VESA mounting hole pattern, from potentially damaging hazards in harsh environments.
- Meets NEMA Type 2 rating- Enclosures constructed for indoor use to provide a degree of protection to personnel against access to hazardous parts; to provide a degree of protection of the equipment inside the enclosure against ingress of solid foreign objects (falling dirt); and to provide a degree of protection with respect to harmful effects on the equipment due to the ingress of water (dripping and light splashing).
- *EME's* support a combined maximum depth of approximately 4.75" for the monitor and display controller/thin client together.
- *EME's* support screens up to 20 lbs.
- A heavy duty hinged back panel opens without tools and allows full access to the interior without removing the enclosure from the mounting system.
- Includes a *Back of Screen Controller Mounting* system that supports a display controller or micro computer on the back of the screen.
- A unique system of four adjustable arms, swing out from each corner to secure the screen at the optimum position inside the enclosure. Adjustment screws allow for easy installation of monitors of varying thickness.
- The entire front panel is made of impact resistant clear plastic that protects the monitor's screen.
- Includes an active ventilation system to maintain air flow and reduce condensation.
- Includes an internal three outlet power strip.
- When the top cover is closed the rear vent section allows for convenient and concealable cable routing.
- This assembly can also be integrated to any of our *Heavy Duty* mounting products to create a support solution for any mounting location.
- For assembly instructions see the *User Manual* which can be downloaded from the *Product Resources* page on our website.
- To order this assembly for enclosing and supporting monitors:
 - Up to 13" H x 18" W use PN 80400 (EME 17-19in)
 - Up to 15" H x 22.5" W use PN 80401 (EME 20-24in)
- Optional Bump Bar mounting kits are available for mounting bump bars directly to the *EME's*.

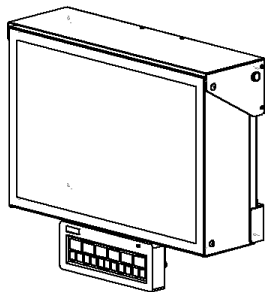

EME WITH MOUNT KIT FOR LOGIC
CONTROLS KB1700 BUMP BAR
(PN 80400-398)

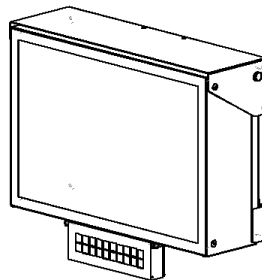

EME WITH MOUNT KIT FOR
QSR KP4000 BUMP BAR
(PN 80400-397)

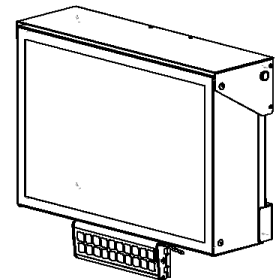

EME WITH MOUNT KIT FOR MICROS
MBB10 & MBB20 BUMP BARS
(PN 80400-399)

Environmental Monitor Enclosure PN 80400-80401

MOUNTING OPTIONS:

- Enclosures mount to any existing 100mm VESA compatible pan and tilt head (note: because of the weight of the enclosure, we recommend mounting to one of our **PQS Heavy Duty Mounting Systems**).

MOUNTING OPTIONS: 35LB CLASS MOUNTING PRODUCTS:

- PQS** offers several mounting options for medium duty applications. All mounts available with 100mm VESA patterns. Most are also available with 200x200 & 200x100mm VESA mounting patterns.

