

PQS

PRACTICAL QUALITY SYSTEMS
Fast Custom Manufacturing - Nationwide Installation Services

Shelving System 72"W with 5 Stainless Steel Shelves PN 81341

Attaches to any wall and includes 2- Galvanized 84" Vertical Shelf Standards, 5- Stainless steel topped 72"W X 14" D shelf assemblies, 10- Galvanized Shelf Brackets and a hardware kit.



Need it installed? We have nationwide professional installation services available. Just contact us!

info@practicalqualitysystems.com

WWW.PRACTICALQUALITYSYSTEMS.COM

(818) 993-1022

ALL PRODUCTS PATENT PENDING

Introduction for all Shelving Systems

We currently manufacture two basic sizes of Shelving Systems; both are 14" deep and are available in widths of 45" and 72". Our Shelving Systems are constructed entirely of stainless and galvanized steel to resist corrosion and harsh environments. Designed to be extra strong; all shelves are engineered with two interior structural support beams.

Value is added across our entire line of Enclosures, Work Tables and Shelving Systems because each has been engineered to be totally modular and compatible with our line of optional equipment. These features insure maximum flexibility when integrating individual components to render a custom solution.

Product Specifications

General Measurements: 72" W x 94"H x 14"D

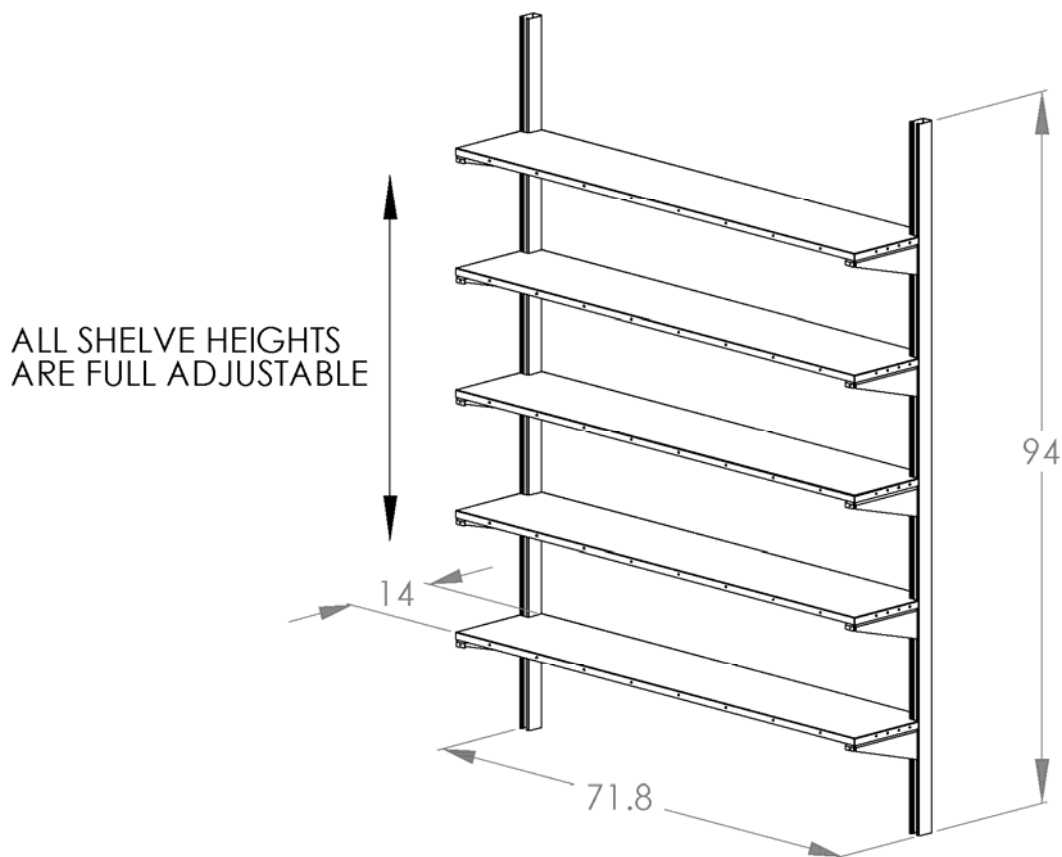

Weight:

72 W 5 Shelf Assembly Bare = approx 234 lbs. Note: This weight does not include any options or accessories.

Engineering Drawing Reference Notes

To view and manipulate 3D models of any assembly; visit www.edrawingsviewer.com and download the free eDrawings viewer software, then open the eDrawing format files (.EASM) found in our Engineering Drawings folders.

For more product dimensional specifications; download the Engineering Drawings folder for files in DWG, PDF and EASM formats on our website from the tool bar on the individual product pages or from our Product Resources page.

User Manual Reference

Refer to manual 10010601-UM for assembly and installation instructions

User manuals are available for download in PDF format on our website from the tool bar on the individual product pages or from our Product Resources page.

Standard Features:**The Vertical Shelf Standards**

The Vertical Shelf Standards are designed to offer the maximum in flexibility. Instead of having a limited number of predetermined shelf locations as with regular systems; these Shelf Standards are made of thick, galvanized steel channels that allow the Shelf Brackets to be attached anywhere along their entire length.

The Vertical Shelf Standards are also pre machined with slots running along the entire length of the back edge where the standards lie against the wall. These slots add mounting flexibility when installing the fasteners that will secure standards to the wall.

Adjusting the height of the shelves is easy, loosen the four mounting bolts, slide the shelf with the Shelf Brackets up or down to the new desired position, then just retighten the mounting bolts.

Shelf Kit 72” Wide

Includes a number of stainless steel topped 71” W X 14”D shelf assemblies that feature two internal support beams, 4- Galvanized Shelf Brackets and a hardware kit. See product short description for quantity.

List of all available options and accessories for Shelving Systems:

Select a preconfigured Shelving System or use our line of Options and Accessories to create a customized solution that fits your exact needs.

Pull Out Work Surface

Full size File Drawers

Half Size Drawers (2)

All in One Drawer Set

Drawer Set with Combo Frame (3)

19" Rack Mount Drawer Kits for Lower Cabinets

Lock Bar Kits (2)

VESA Monitor and POS Printer Mounts for Enclosure interiors, Work Tables or Shelving Systems (4)

Cross bars for Shelving Systems for Monitor or Printer Mounts (3)

Bin Boxes (3)

Bin Box Mounting Bars for Bin Boxes for Shelving Systems (2)

Bin Box Mounting Bars for Enclosure interiors (3)

Additional Upper Shelf Kits (4)

Additional Lower Shelf Kits (2)

Fluorescent Strip Lights (2)

Multiple Outlet Power Strips 36"L (2)

Modular Ventilation Systems and Fans (2)

Table Top Protectors (2)