

Bin Box 5 3/8" L x 4 1/8" W x 3" H PN 30025
Bin Box 7 3/8" L x 4 1/8" W x 3" H PN 30026
Bin Box 10 7/8" L x 5 1/2" W x 5" H PN 30027

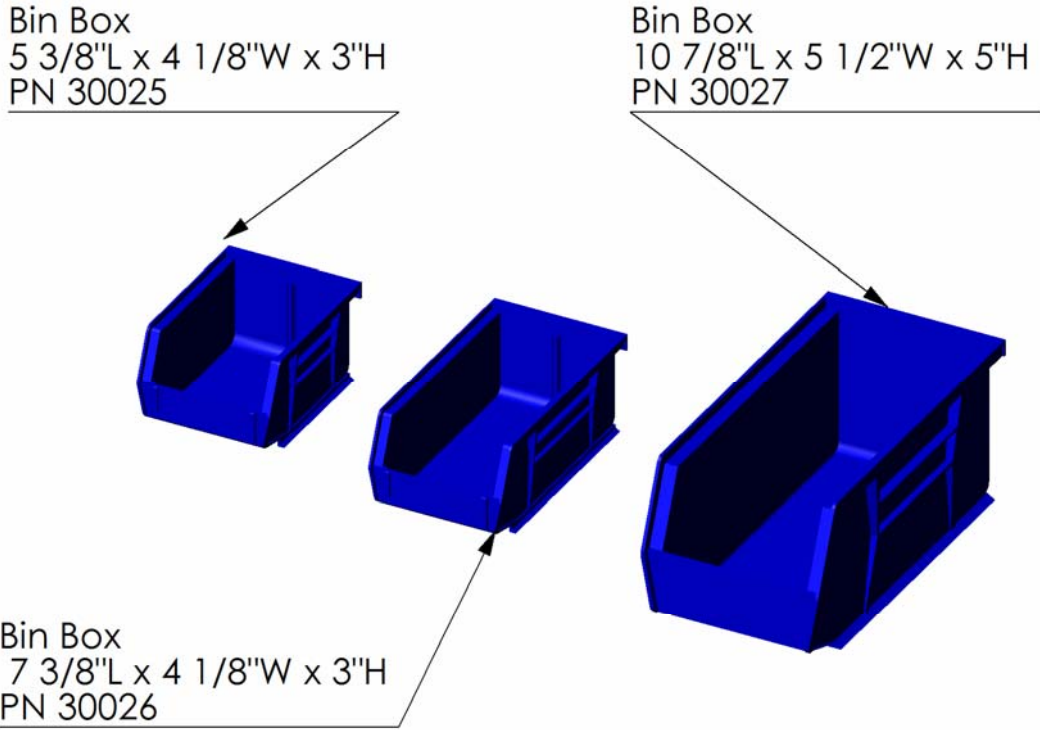

Product Specifications:

- Can be attached directly to any Bin Box Mounting Bar that is installed horizontally between any two shelf standards or on any enclosure rear panel.
- These bins have a built in hanging edge along the back and are molded of high-impact polypropylene.
- Their sturdy, one-piece construction is water, rust and corrosion-proof and they are unaffected by grease, oils, weak acids, or alkalis.
- They feature a curved-bottom hopper front which makes it easy to retrieve small items.
- They come in the color blue standard.

Engineering Drawing Reference Notes

To view and manipulate 3D models of any assembly; visit www.edrawingsviewer.com and download the free eDrawings viewer software, then open the eDrawing format files (.EASM) found in our Engineering Drawings folders.

For more product dimensional specifications; download the Engineering Drawings folder for files in DWG, PDF and EASM formats on our website from the tool bar on the individual product pages or from our Product Resources page.

User Manual Reference

Refer to manual 10010702-UM for assembly and installation instructions

User manuals are available for download in PDF format on our website from the tool bar on the individual product pages or from our Product Resources page.