

PQS

PRACTICAL QUALITY SYSTEMS

Fast Custom Manufacturing - Nationwide Installation Services

UVHM-FM-WS4

A single position flat mounting plate with a 3" or 6" riser, one 8" arm and a WS4 tilt head

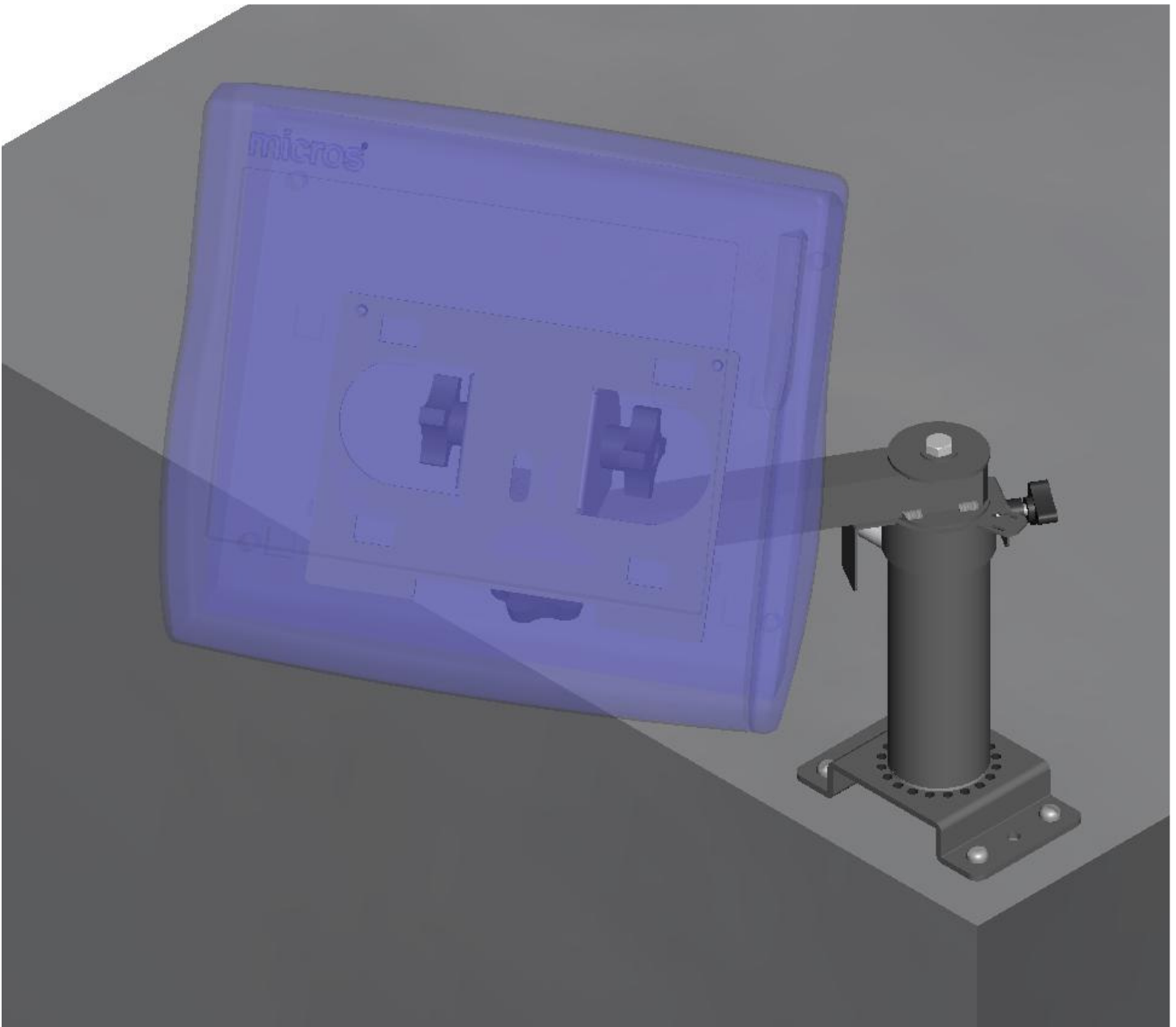

All Products Patent Pending

UVHM-FM-WS4

A single position flat mounting plate with a 3" or 6" riser, one 8" arm and a WS4 tilt head

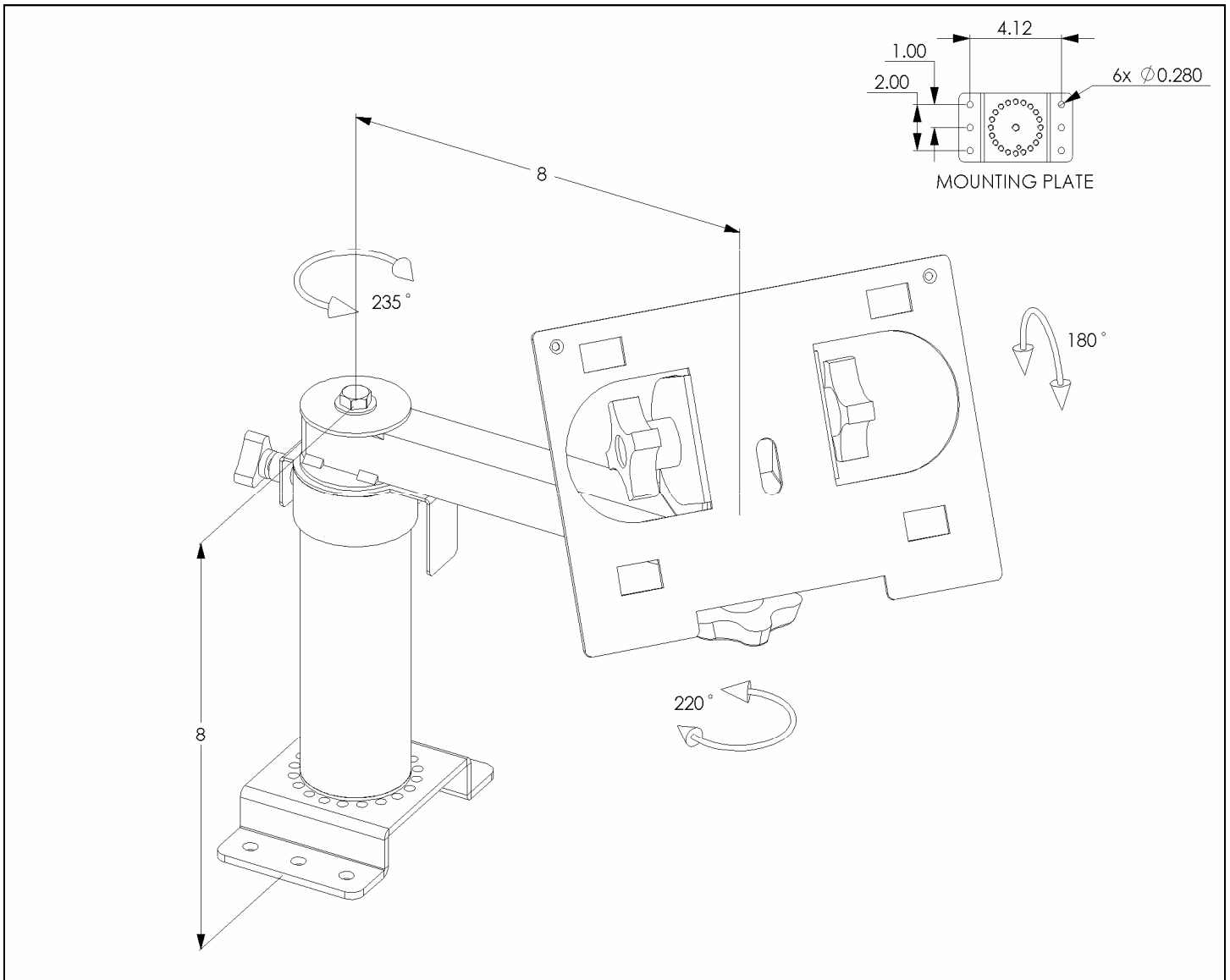

PRODUCT ASSEMBLIES

- UVHM-FM-R6-WS4: PN 80082
A single position flat mounting plate with a 6" riser, an 8" arm and a WS4 tilt head
- UVHM-FM-R3-WS4: PN 80083
A single position flat mounting plate with a 3" riser, an 8" arm and a WS4 tilt head

UVHM-FM-WS4

A single position flat mounting plate with a 3” or 6” riser, one 8” arm and a WS4 tilt head

PRODUCT SPECIFICATIONS

- Supports a MICROS WS4 terminal.
- Attaches to a counter top, shelf or any other flat horizontal surface.
- WS4 tilt head adjusts without tools to lock the screen at any position, side to side, or up and down.
- In some cases it is recommended to install a screen on a 6 inch riser and printer on a 3 inch riser.
- A 3” or 6” riser elevates the 8” arm above the mounting surface and permits the tilt head to travel horizontally to allow a wide range of screen locations.
- Add an optional P3 plate, a riser, and an arm with a UPMT to support a printer right next to the terminal.
- Integral stop details on the riser and arm can be located at any setting to prevent cable damage when the arm supporting the screen or the printer is rotated around the riser.
- The arms can rotate freely or be locked in any position horizontally without tools at the riser cap.
- The tilt head includes integral stop details that limit a full rotation to the right or left to prevent cable damage.
- The tilt head can be easily removed from the arm and attached directly to the top of the riser.
- The riser cap incorporates a cable tie point to secure the cables so that they will travel safely as the arm is rotated.
- The position of the tilt head can also be locked more securely for the long term by tightening the tilt head locking screws with a Phillips screw driver.
- This assembly is part of the UVHM system which includes many components that can be mixed and matched to create a support solution for any mounting location. Most of the UVHM assemblies can be easily reconfigured in the field for a different application by either adding or deleting a few parts.
- Please specify either 3" or 6" riser(s) when ordering.
- Each arm supports up to 15 lbs.