

PQS

PRACTICAL QUALITY SYSTEMS
Fast Custom Manufacturing - Nationwide Installation Services

Custom Fit Flat Wall Mount for Partner Tech SP1000 PN 80910-403

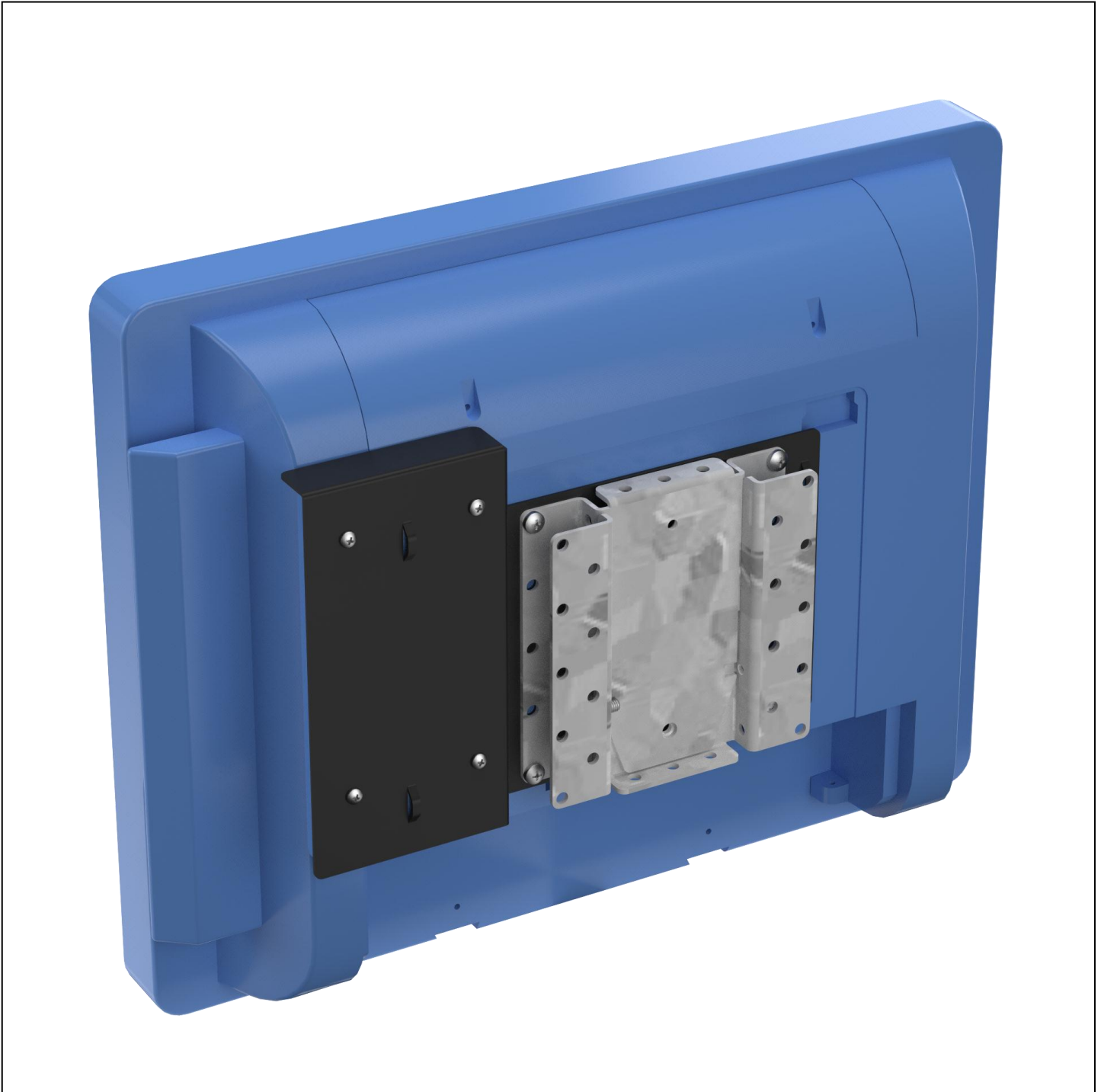

NOTE: 80910-403 shown with a Partner Tech SP1000 terminal, and its external SATA hard drive installed.

info@practicalqualitysystems.com

WWW.PRACTICALQUALITYSYSTEMS.COM

(818) 993-1022

ALL PRODUCTS PATENT PENDING

Custom Fit Flat Wall Mount for Partner Tech SP1000 PN 80910-403

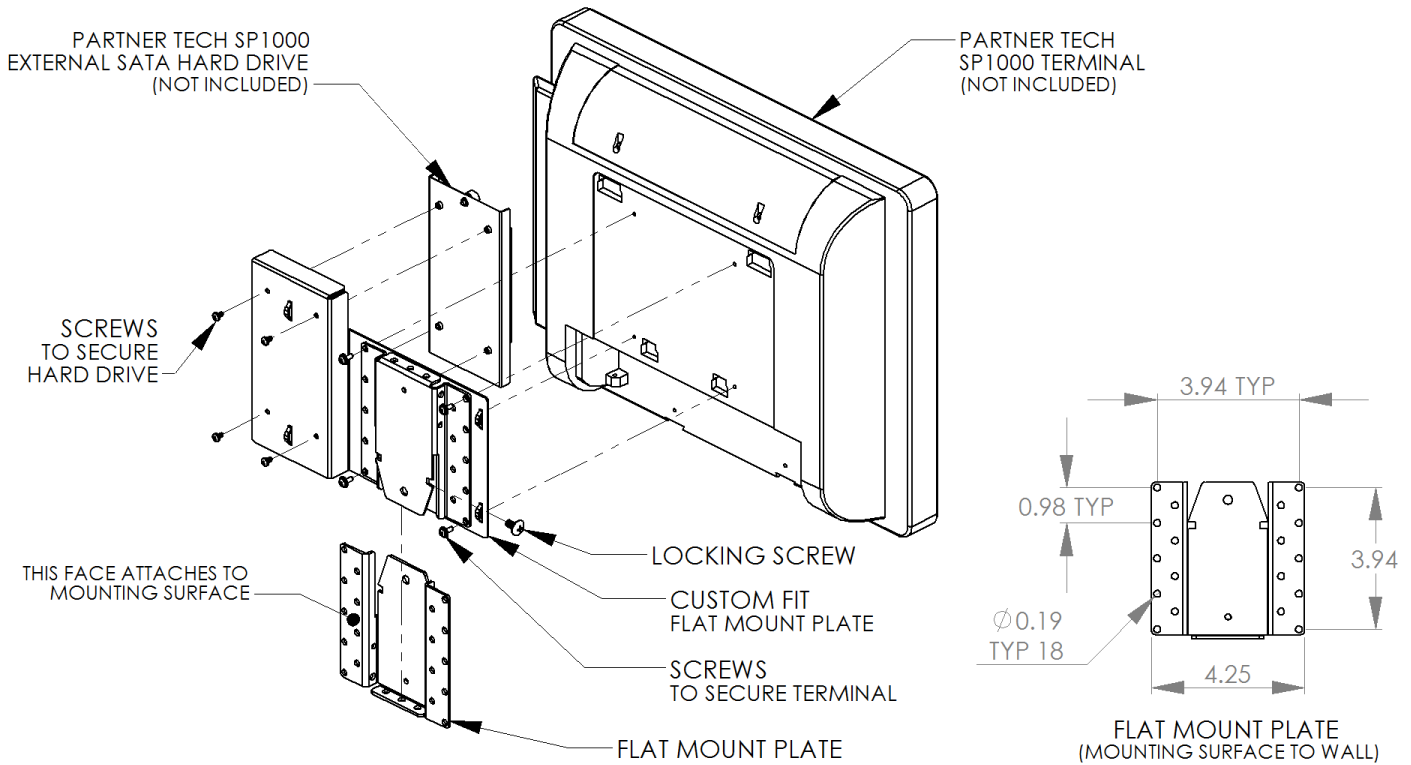

PRODUCT SPECIFICATIONS

- Supports a Partner Tech SP1000 touch screen Terminal.
- Attaches to a wall or any other flat vertical surface.
- The *Custom Fit* mount provides a semi-enclosed secure mounting location for the Partner Tech SP1000 external SATA hard drive.
- The terminal and external SATA hard drive are secured using thumbscrews for easy removal.
- 10-32 screws secure brackets in place at locking screw locations.
- Optional *USB Speaker Bar System* for the Partner Tech SP1000 can be mounted directly to the back of the terminal (See PN 80990).
- PQS also offers a flat mount bracket for dual Partner Tech SP1000 terminals (see PN 80911-403).
- For assembly instructions see the *User Manual* which can be downloaded from the *Product Resources* page on our website.
- All mounting systems are available with *Custom Fit* Pan and Tilt Heads for all non VESA compatible screens. Refer to the *Custom Fit Pan and Tilt Heads* page on our website for a current list of all non VESA compatible pan and tilt heads. If we don't currently have a pan and tilt head to fit your screen, we can create one for you.

OPTIONAL USB SPEAKER BAR SYSTEM (PN 80990)

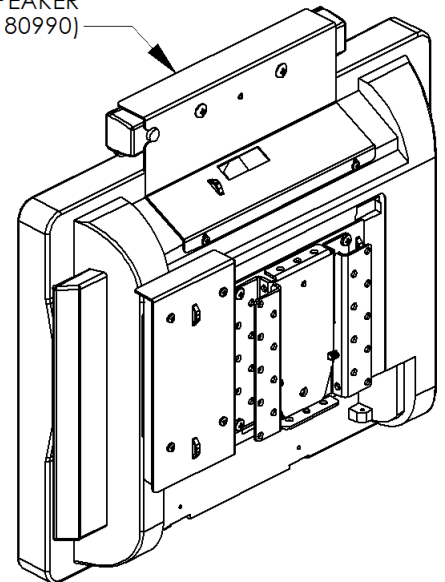

Custom Fit Flat Wall Mount for Partner Tech SP1000 PN 80910-403

MOUNTING OPTIONS:

- PQS also offers flat mount brackets for monitors with 75/100mm (PN 80910) & 100/200mm (PN 80913) VESA compatible mounting configurations.
- This assembly is one of our modular mounting systems. This system includes many components which can be mixed and matched to create a custom support solution for any mounting location. Most of our modular mounting system assemblies can be easily reconfigured in the field for a different application by either adding or removing a few parts.
- All of our screen pan and tilt heads including our *Custom Fit* products can be used with any of the following mounting systems.

