

PQS

PRACTICAL QUALITY SYSTEMS

Fast Custom Manufacturing - Nationwide Installation Services

PED-1 Pedestal mounting system

PN 80150

A multi armed system that supports the maximum amount of equipment in a minimum amount of space

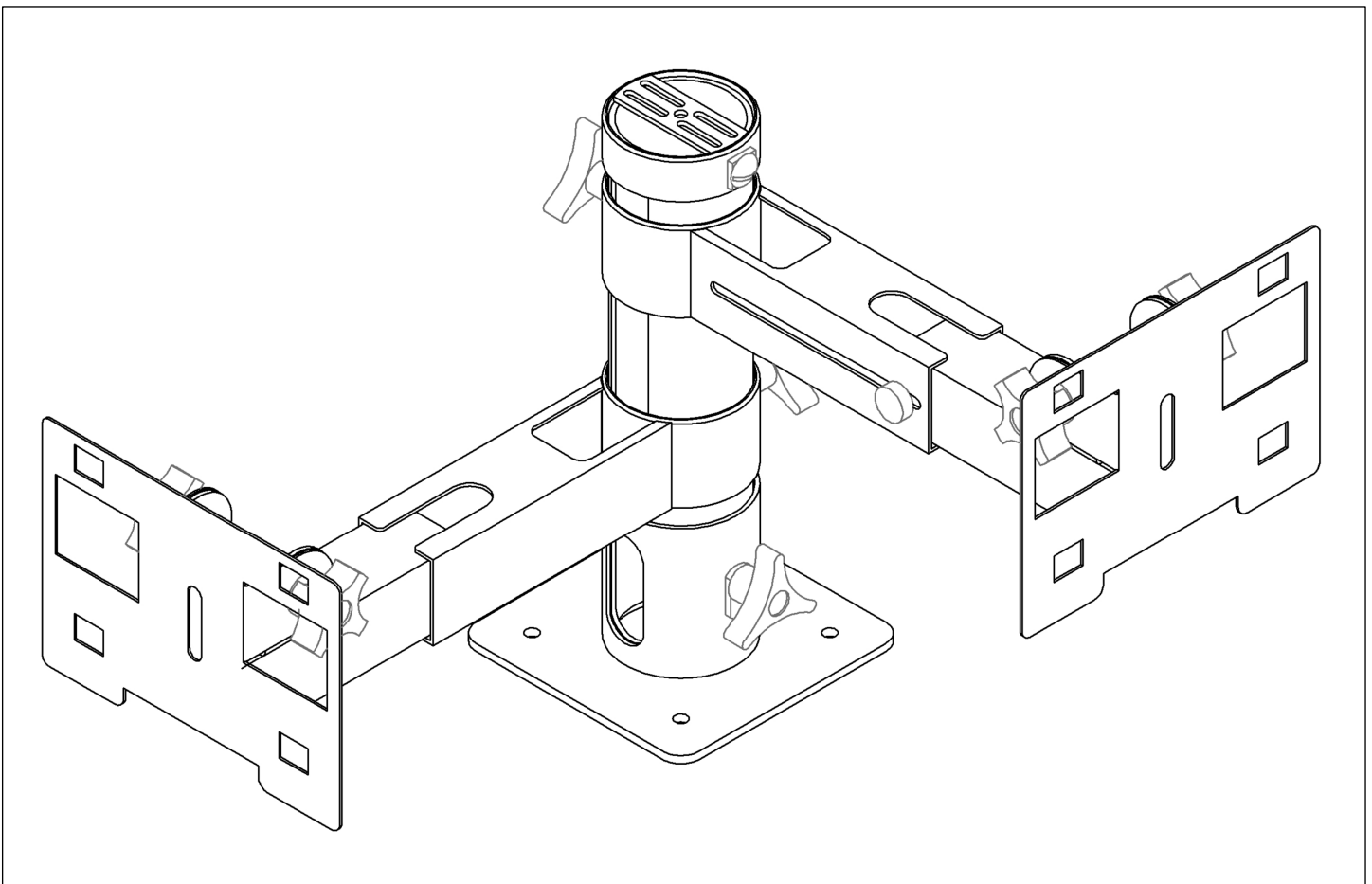

A multi armed system that supports the maximum amount of equipment in a minimum amount of space

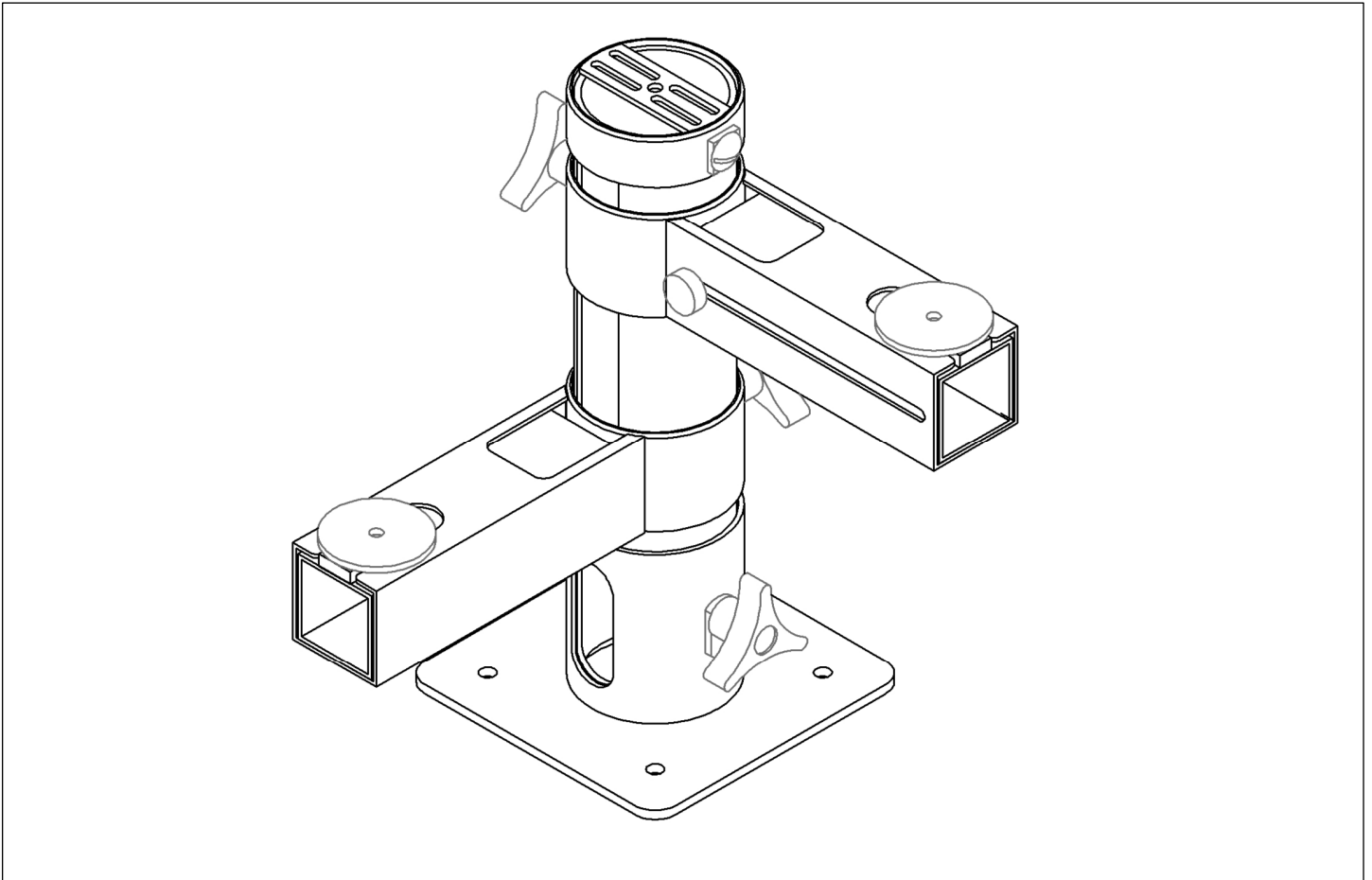

A multi armed system that supports the maximum amount of equipment in a minimum amount of space**PRODUCT SPECIFICATIONS**

- Our PED-1 system is a total solution for mounting all of your POS equipment designed to maximize use of the available counter top space. With this system you can now have two complete terminals and all of their peripheral equipment supported above only six square inches of counter top space.
- The center pedestal section is hollow to permit all of the associated cabling to be routed vertically within it and it features an opening along its entire length. This feature allows the associated cabling to enter at any point along the pedestal and then it can exit at the base from the side or straight out through the bottom of the base.
- The supporting arms can rotate 360° around the pedestal and they can be raised and lowered to be locked down in any position along its entire height. The supporting arms are also telescopic and can extend out from 5" to 10" and will support up to thirty pounds each.
- Our optional cash drawer pedestal mounting base (CDPMB) option uses a standard cash drawer as a base for the PED 1 system. With this solution, no tools are needed for installation and no fasteners are installed into the counter top.
- All of our UMT mounting trays can be attached directly to the end of the supporting arms and then can be tilted or rotated.
- Our WS4 and VESA tilt heads permit touch screens or monitors to be rotated, tilted and then locked down at any desired position.
- The top cap of the pedestal permits the mounting of pole displays or signage.
- Center sections are available in 18 and 24 inch lengths. Longer custom lengths can also be ordered as needed.
- It is even possible to extend the center section from floor to ceiling to create a freestanding solution to support multiple terminals, printers and cash drawers.