

A 19" wall mountable equipment rack that is 12" deep and has 4U of rack space

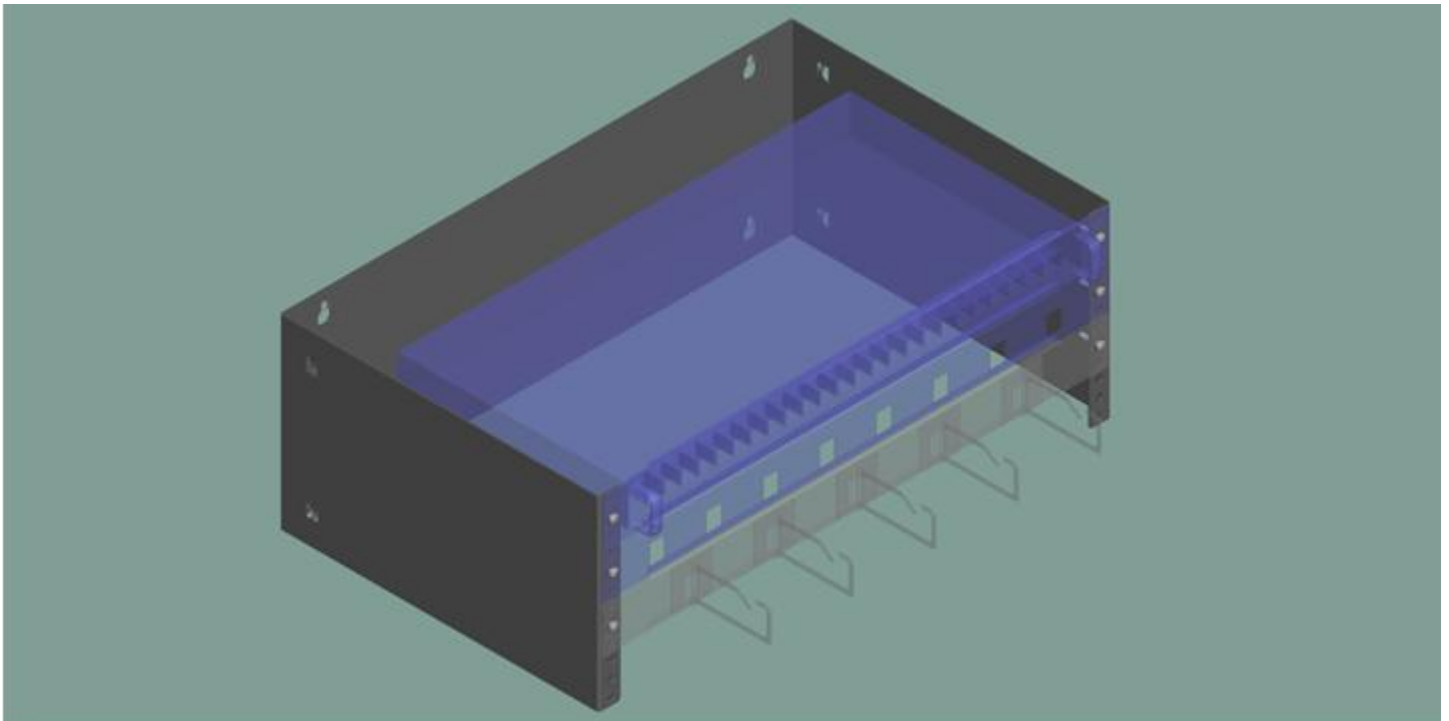

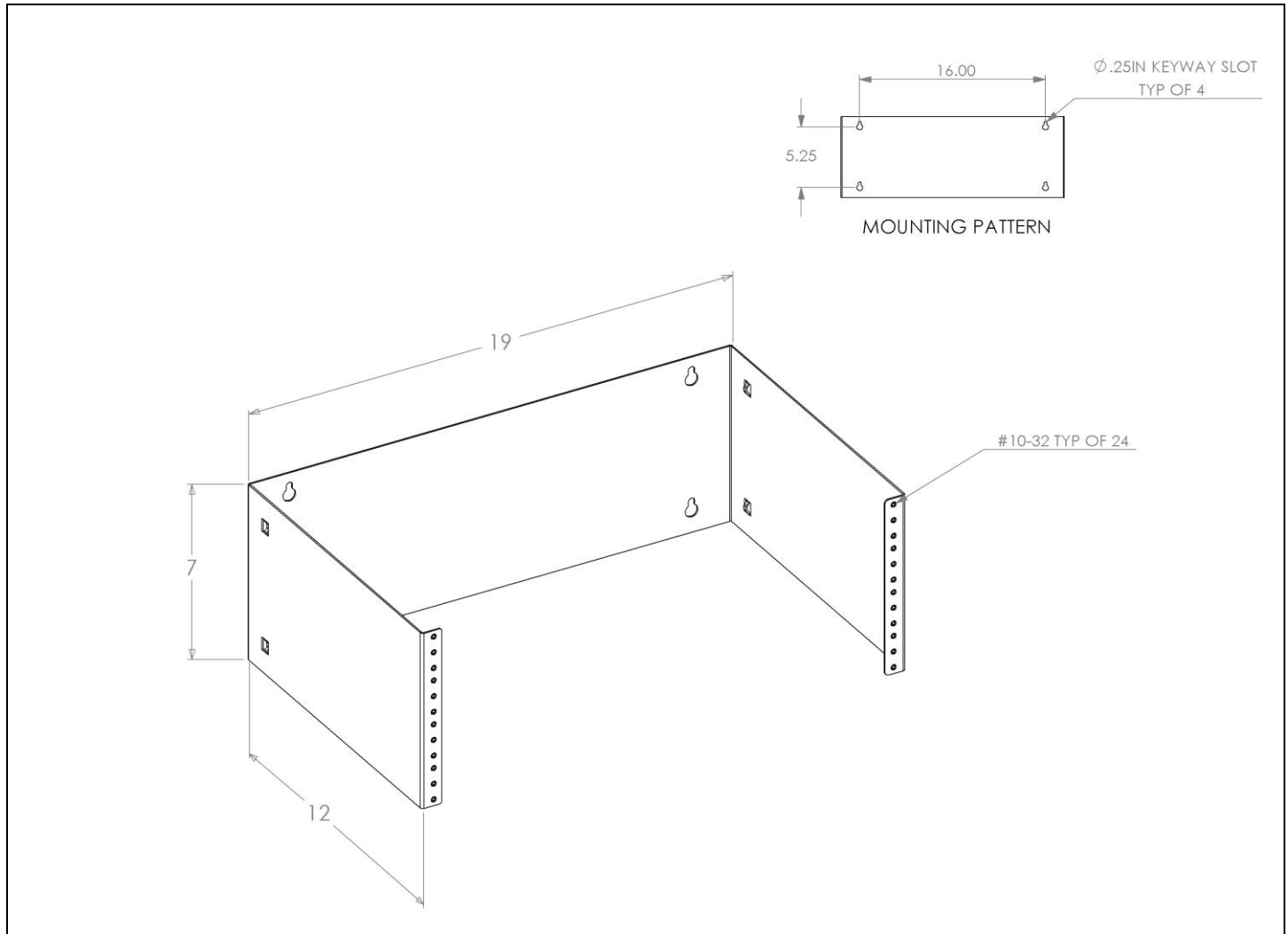

PRODUCT SPECIFICATIONS

- We designed our 19-12-4U WMB 19" wall rack mount bracket to support network switches or other equipment up to 12" deep.
- The 19-12-4U WMB has 4U's (or equipment units) of standard 19" rack mounting space. That's enough to support a standard network data switch, a 24 port network patch panel, a cable management detail and still have 1U of rack space open.
- The 19-12-4U WMB wall rack mount bracket includes several convenient integral cable tie points along the back.
- Use with our optional WRS18-10 wire rack shelf that is 10" deep, and is the perfect location to install peripheral devices such as network switches, hubs, modems, router, etc. that are NOT rack mountable. The WRS18-10 wire rack shelf is designed to attach directly to the wall either above or below the WMB 19-12-4U 19" wall rack mount bracket.
- Add an optional 8P1UKPP 8 port patch panel with standard RJ11 jacks to create a patch panel for all of your telephone cabling and install all of your peripheral components such as modems, routers, etc. in the adjacent WRS18-10 wire rack shelf for a totally organized data / telecom center.