

# PQS

## PRACTICAL QUALITY SYSTEMS

*Fast Custom Manufacturing - Nationwide Installation Services*

### UVHM-UC-R-VESA

A one position under counter mounting plate with one 3" or 6" riser, an 8" arm and a VESA tilt head

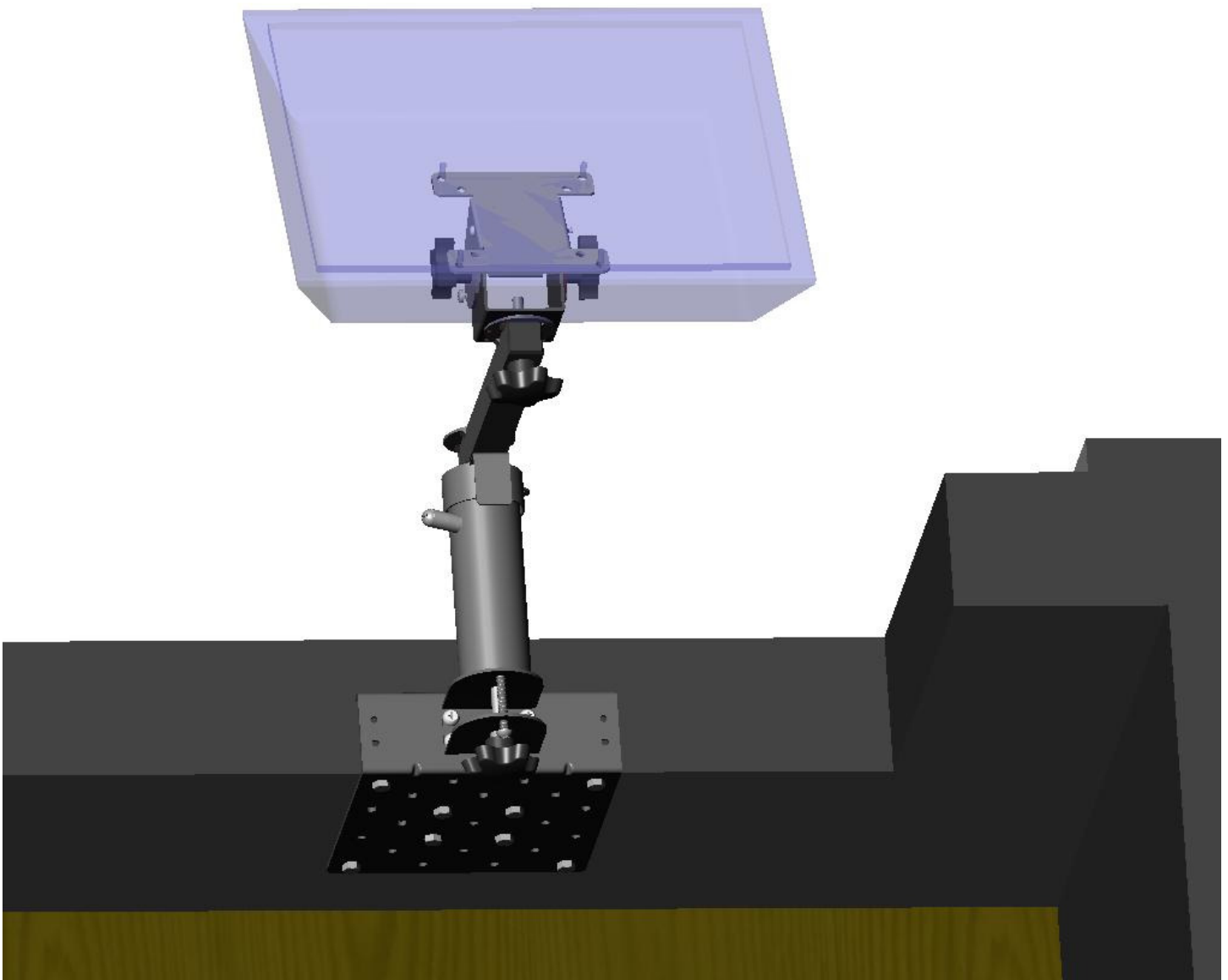

## UVHM-UC-R-VESA

A one position under counter mounting plate with one 3" or 6" riser, an 8" arm and a VESA tilt head

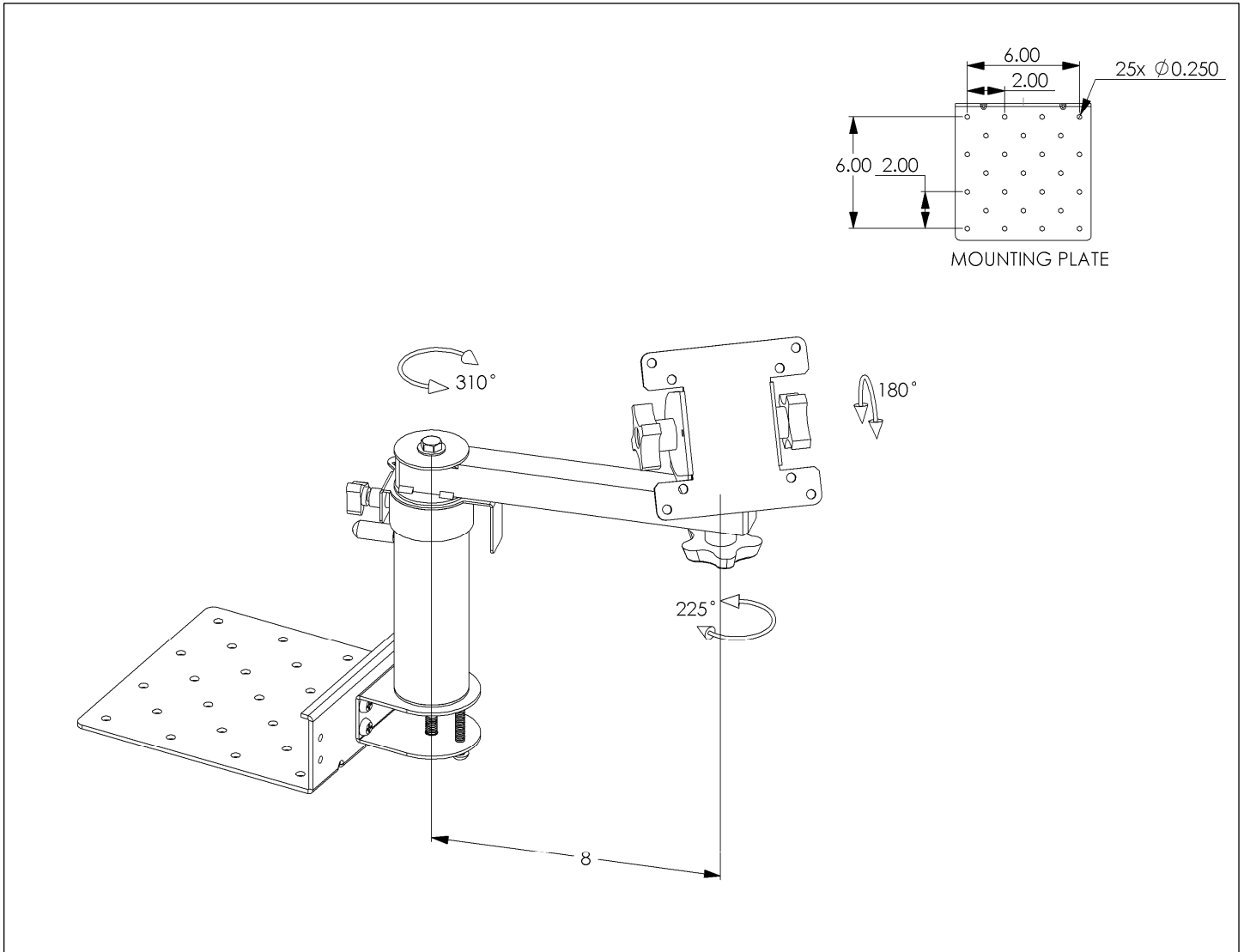

### PRODUCT ASSEMBLIES

- UVHM-UC-R6-VESA: PN 80240  
A single position under counter mounting plate with one 6" riser, one 8" arm and a VESA tilt head
- UVHM-UC-R3-VESA: PN 80241  
A single position under counter mounting plate with one 3" riser, one 8" arm and a VESA tilt head

## UVHM-UC-R-VESA

### **A one position under counter mounting plate with one 3” or 6” riser, an 8” arm and a VESA tilt head**

#### PRODUCT SPECIFICATIONS

- Supports a Micros WS5 terminal or any 75 or 100 mm VESA compatible touch screen, terminal or flat panel monitor.
- The assembly supports touch screens, terminals or flat panel monitors up to 20” (all images are shown with a 17” screen).
- Attaches underneath of a counter top, a shelf or any other flat horizontal surface.
- VESA tilt head adjusts without tools to lock the screen at any position, side to side, or up and down.
- The position of the tilt head can be locked more securely for the long term by tightening the tilt head locking screws with a Phillips screw driver.
- In some cases it is recommended to install a screen on a 6 inch riser and printer on a 3 inch riser.
- The 3” or 6” risers elevate the 8” arms above the mounting surface and allow the screen to travel horizontally and permit a wide range positioning locations.
- Integral stop details on the riser and arm can be located at any setting to prevent cable damage when the arm supporting the screen is rotated around the riser.
- The arms can rotate freely or be locked in any position horizontally without tools at the riser cap.
- The tilt head includes integral stop details that limit a full rotation to the right or left to prevent cable damage.
- The tilt head or printer can be easily removed from the arm and attached directly to the top of the riser.
- The riser cap incorporates a cable tie point to secure the cables so that they will travel safely as the arm is rotated.
- This assembly is part of the UVHM system which includes many components that can be mixed and matched to create a support solution for any mounting location. Most of the UVHM assemblies can be easily reconfigured in the field for a different application by either adding or deleting a few parts.
- Please specify either 3" or 6" riser(s) when ordering.
- Each arm supports up to 15 lbs.