

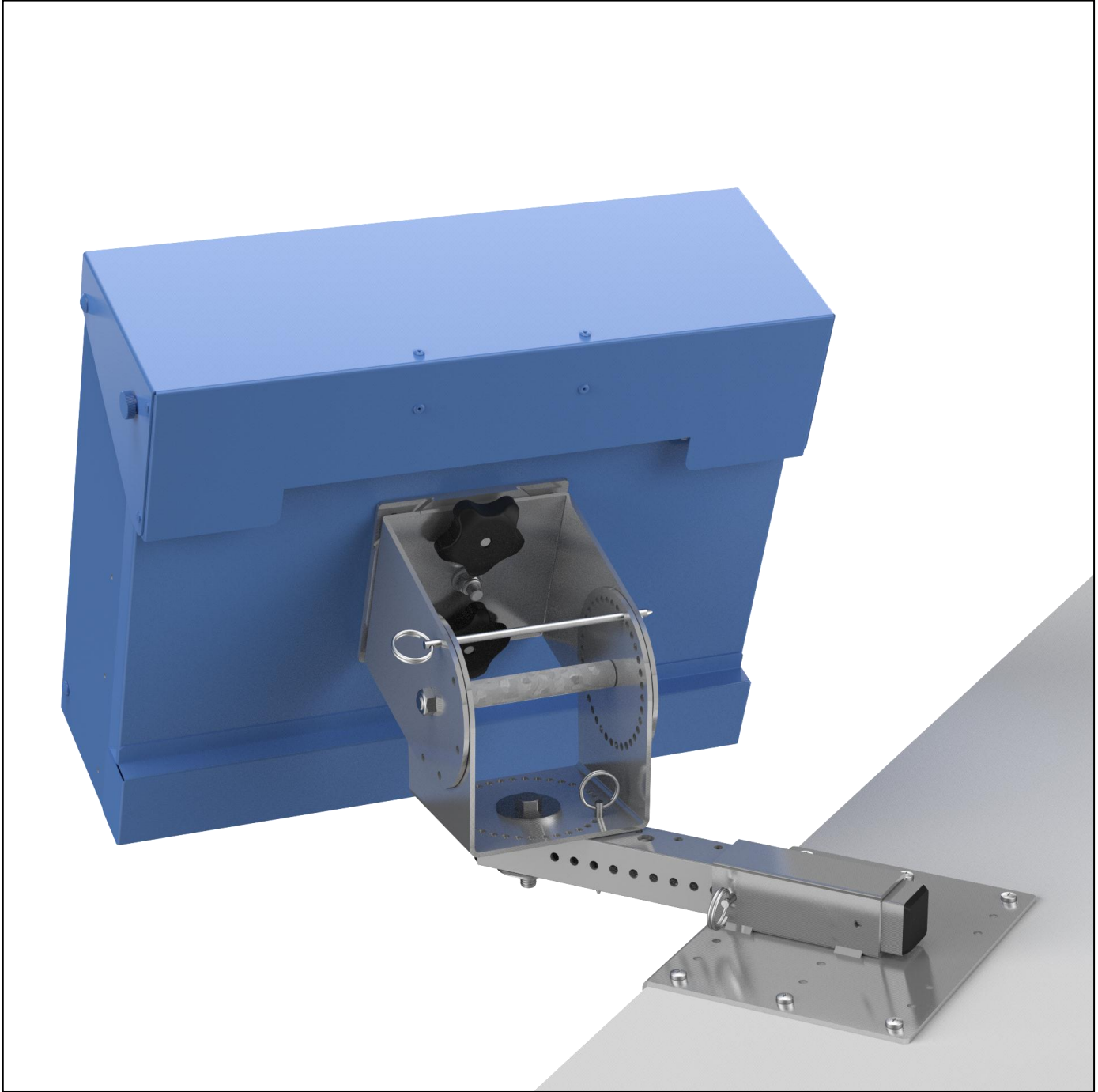

PRACTICAL QUALITY SYSTEMS
Fast Custom Manufacturing - Nationwide Installation Services

35 LB Shelf Edge Mount w-100mm VESA Pan & Tilt Head PN 80973



NOTE: 35LB Shelf Edge Mount with a 100mm VESA Pan and Tilt head shown with PQS APK Enclosure (PN 80402) Also available with 200x200mm and 200x100mm VESA pan and tilt heads.

info@practicalqualitysystems.com

WWW.PRACTICALQUALITYSYSTEMS.COM

(818) 993-1022

ALL PRODUCTS PATENT PENDING

35 LB Shelf Edge Mount w-100mm VESA Pan & Tilt Head PN 80973

PRODUCT SPECIFICATIONS

- For NON VESA compatible pan and tilt heads use 80973 and add the part number suffix found on the *Custom Fit Pan and Tilt Heads* page on our website. The page can be found listed under the "Other Products" section.

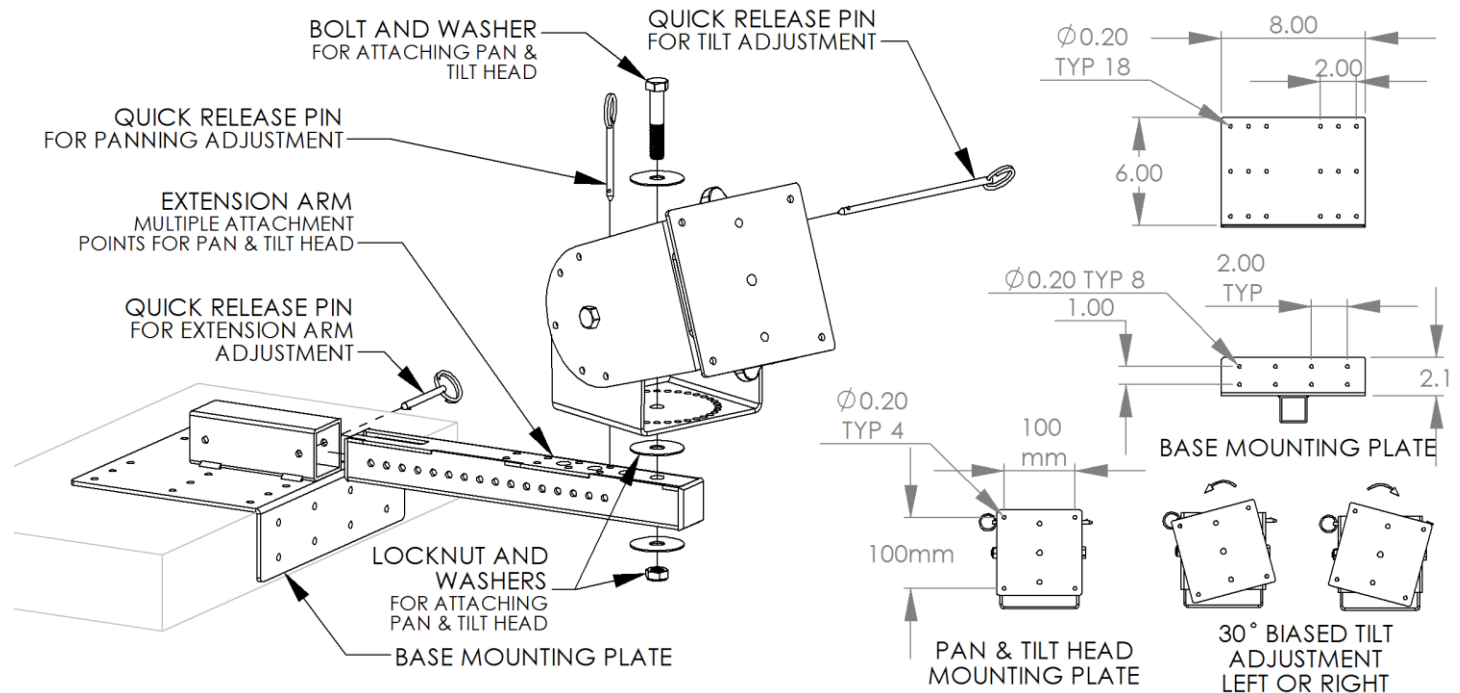

- If the website doesn't show a suffix that represents your compatible pan and tilt head then send us a sample of your screen and we'll create a *Custom Fit* solution for you.
- PQS** offers several mounting options for medium duty applications. All mounts available with 100mm VESA patterns.
- The assembly supports touch screens, terminals or flat panel monitors up to 35LBs.
- Attaches to a shelf or any flat horizontal surface edge.
- The VESA pan and tilt head adjusts without tools to lock the screen at any position, side to side, or up and down allowing for a wide range of screen locations.
- Available with pan and tilt heads to support all VESA and NON VESA compatible touch screens, terminals or flat panel monitors.
- To order this assembly with a 75/100mm VESA compatible screen pan and tilt head; use part number 80973.
- To order this assembly with a *Custom Fit*, NON VESA compatible screen tilt head; use part number 80973 and add the part number suffix found on the *Custom Fit Pan and Tilt Heads* page on our website. The page can be found listed under the *Other Products* section. If the website doesn't show a suffix that represents a type that is compatible with your screen pan and tilt head; send us a sample of your screen and we'll create a *Custom Fit* solution for you.

35 LB Shelf Edge Mount w-100mm VESA Pan & Tilt Head PN 80973

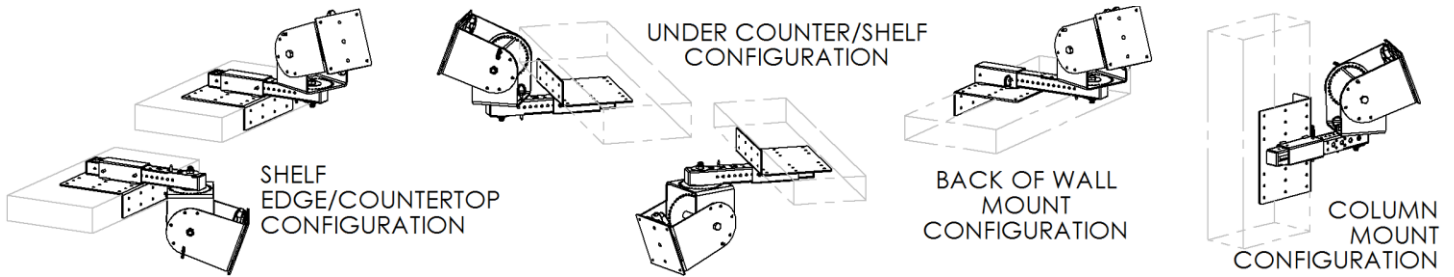

INSTALLATION INSTRUCTIONS

- This assembly can be oriented and installed in a number of different configurations.
- The installation instructions below are similar for all configurations.

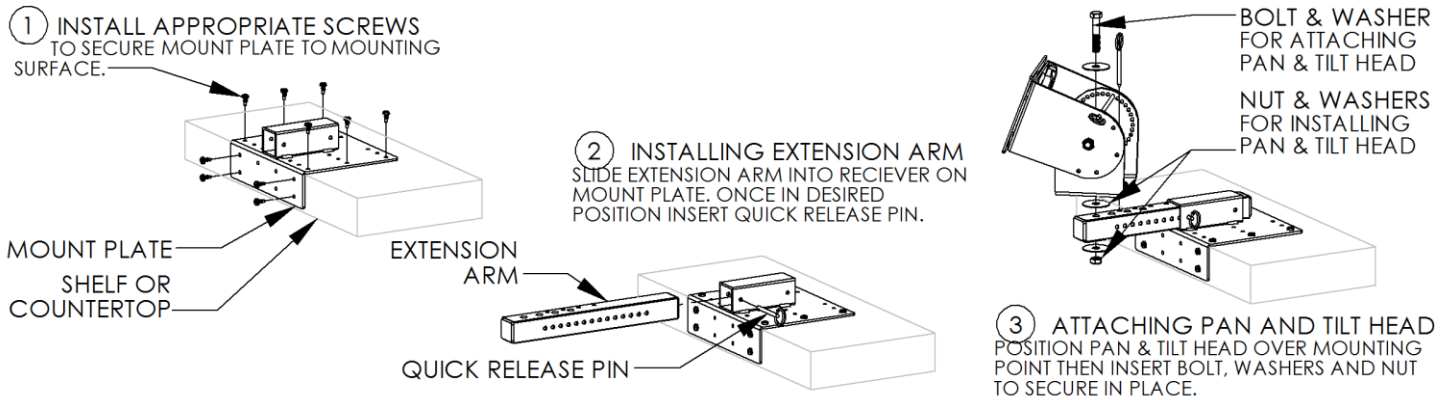

MOUNTING OPTIONS: 35LB CLASS MOUNTING PRODUCTS:

- **PQS** offers several mounting options for medium duty applications. All mounts available with 100mm VESA patterns.

