

# PQS

**PRACTICAL QUALITY SYSTEMS**  
*Fast Custom Manufacturing - Nationwide Installation Services*

## Environmental Monitor Enclosure with QSR Bump Bar Mount PN 80400-397 & 80401-397

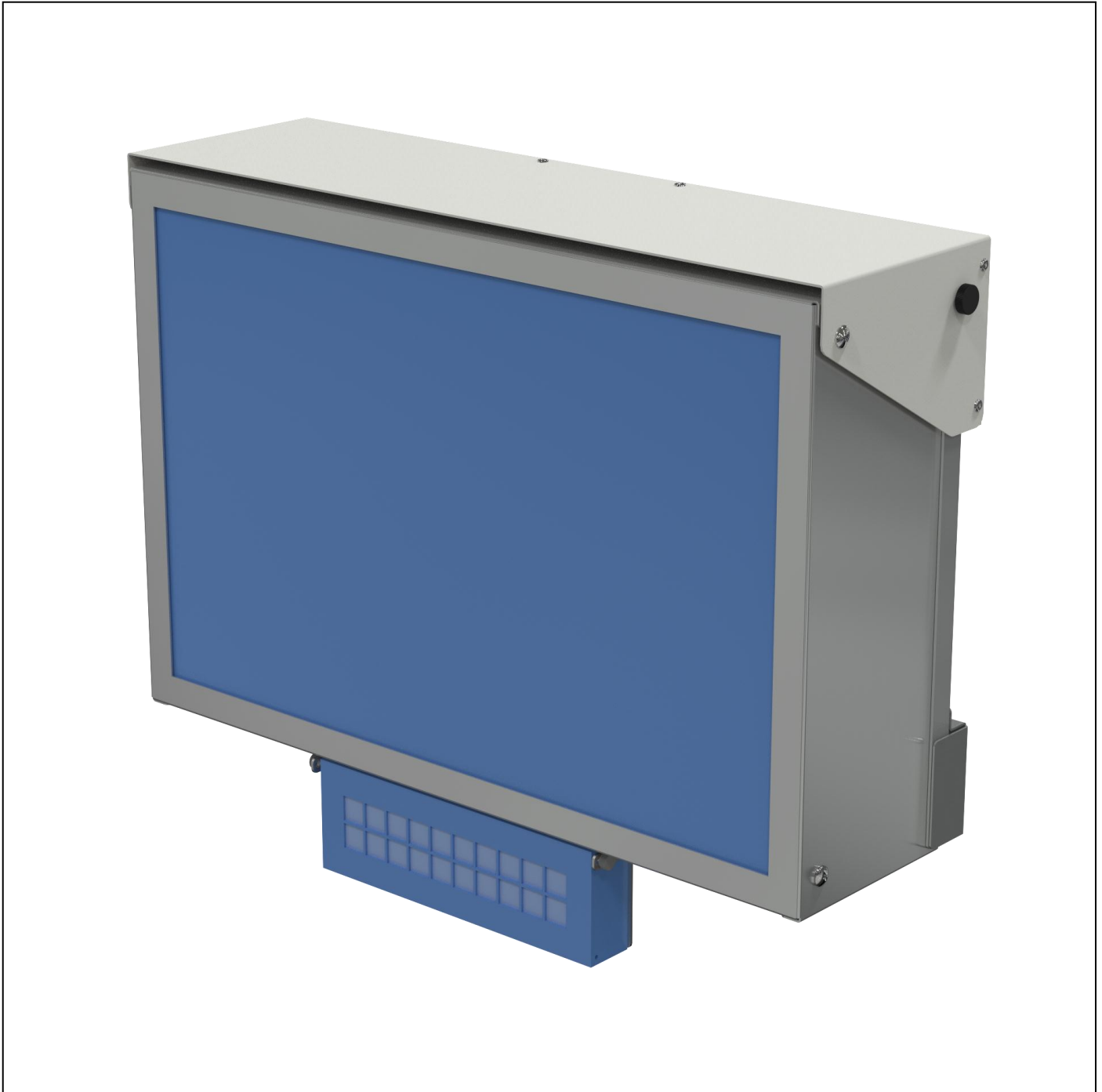

Note: 80400-397 Environmental Enclosure for 17"-19" flat panel monitors shown with QSR Bump Bar. Also available for 20" to 24" monitor.

[info@practicalqualitysystems.com](mailto:info@practicalqualitysystems.com)

[WWW.PRACTICALQUALITYSYSTEMS.COM](http://WWW.PRACTICALQUALITYSYSTEMS.COM)

(818) 993-1022

**ALL PRODUCTS PATENT PENDING**

### Environmental Monitor Enclosure with QSR Bump Bar Mount PN 80400-397 & 80401-397

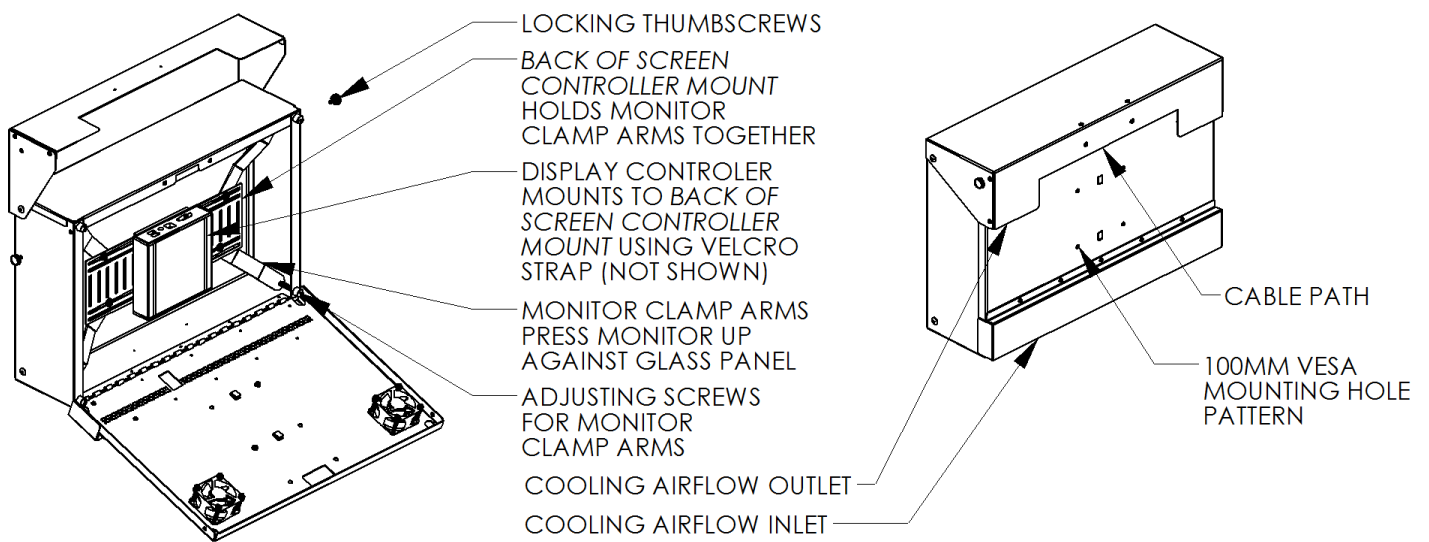
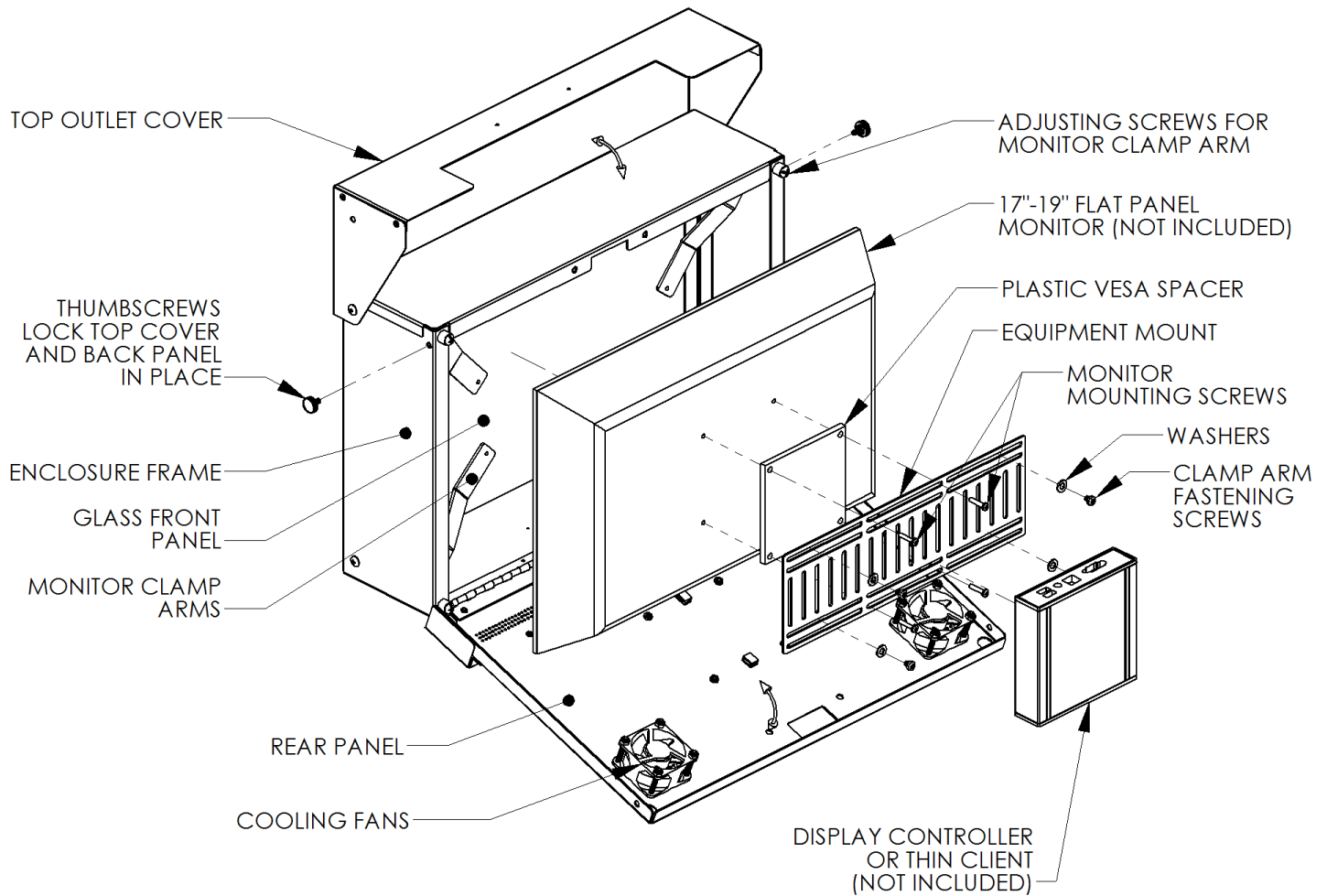

## Environmental Monitor Enclosure with QSR Bump Bar Mount PN 80400-397 & 80401-397

### PRODUCT SPECIFICATIONS:

- *Environmental Monitor Enclosures (EME)* protects any flat screen monitor 17"-24," with either a 75mm or 100mm VESA mounting hole pattern, from potentially damaging hazards in harsh environments.
- Meets NEMA Type 2 rating- Enclosures constructed for indoor use to provide a degree of protection to personnel against access to hazardous parts; to provide a degree of protection of the equipment inside the enclosure against ingress of solid foreign objects (falling dirt); and to provide a degree of protection with respect to harmful effects on the equipment due to the ingress of water (dripping and light splashing).
- *EME's* support a combined maximum depth of approximately 4.75" for the monitor and display controller/thin client together.
- *EME's* support screens up to 20 lbs.
- A heavy duty hinged back panel opens without tools and allows full access to the interior without removing the enclosure from the mounting system.
- Includes a *Back of Screen Controller Mounting* system that supports a display controller or micro computer on the back of the screen.
- A unique system of four adjustable arms, swing out from each corner to secure the screen at the optimum position inside the enclosure. Adjustment screws allow for easy installation of monitors of varying thickness.
- Includes *Bump Bar Mounting System* for QSR bump bars.

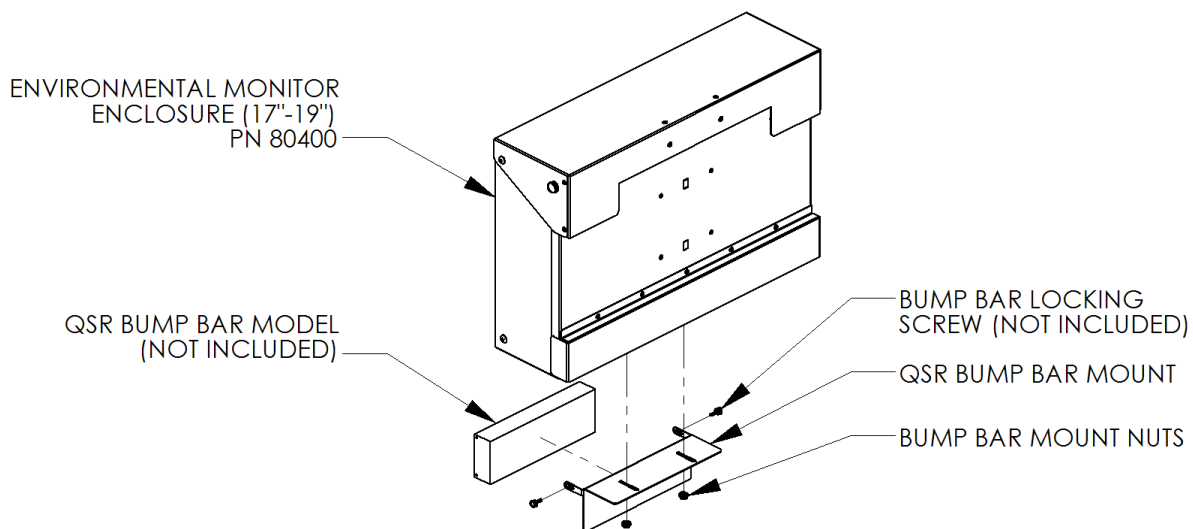

Note: 80400-397 *Environmental Monitor Enclosure* for 17"-19" flat panel monitors shown with *QSR Bump Bar*.

- The entire front panel is made of impact resistant clear plastic that protects the monitor's screen.
- Includes an active ventilation system to maintain air flow and reduce condensation.
- Includes an internal three outlet power strip.
- When the top cover when is closed the rear vent section allows for convenient and concealable cable routing.
- This assembly can also be integrated to any of our *35LB Mounting Products* to create a support solution for any mounting location.
- For assembly instructions see the *User Manual* which can be downloaded from the *Product Resources* page on our website.

## Environmental Monitor Enclosure with QSR Bump Bar Mount PN 80400-397 & 80401-397

- To order this assembly for enclosing monitors and supporting bump bars:
  - Up to 13" H x 18" W use PN 80400-397 (EME 17-19in)
  - Up to 15" H x 22.5" W use PN 80401-397 (EME 20-24in)

Also available without bump bar support mounts:

- Up to 13" H x 18" W w/o bump bar mount use PN 80400 (EME 17-19in)
- Up to 15" H x 22.5" W w/o bump bar mount use PN 80401 (EME 20-24in)

### MOUNTING OPTIONS:

- Enclosures mount to any existing 100mm VESA compatible pan and tilt head (note: because of the weight of the enclosure, we recommend mounting to one of our **PQS 35LB Mounting Systems**).

### MOUNTING OPTIONS: 35LB CLASS MOUNTING PRODUCTS:

- **PQS** offers several mounting options for our *Environmental Monitor Enclosures* and other medium duty applications. Most are also available with 200x200 & 200 x 100mm VESA mounting patterns.

