

PQS

PRACTICAL QUALITY SYSTEMS
Fast Custom Manufacturing - Nationwide Installation Services

35LB Over/Under Counter/Shelf Mount w-100mm VESA Pan & Tilt Head PN 80970



35LB Over/Under Counter/Shelf Mount PN 80971 with a 100mm VESA Pan and Tilt head. Shown with 15" monitor in over and in under mount configurations. Also available with 200x200mm and 200x100mm VESA pan and tilt heads.

info@practicalqualitysystems.com

WWW.PRACTICALQUALITYSYSTEMS.COM

(818) 993-1022

ALL PRODUCTS PATENT PENDING

35LB Over/Under Counter/Shelf Mount w-100mm VESA Pan & Tilt Head PN 80970

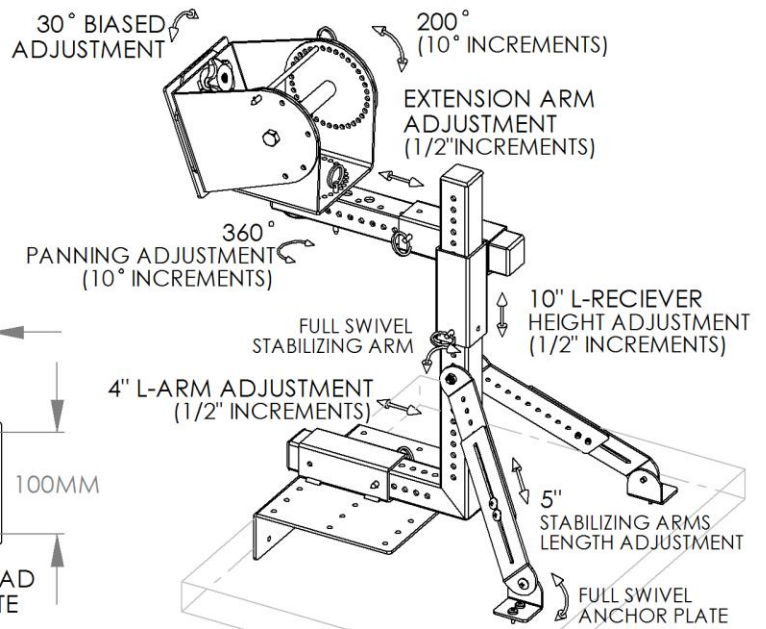
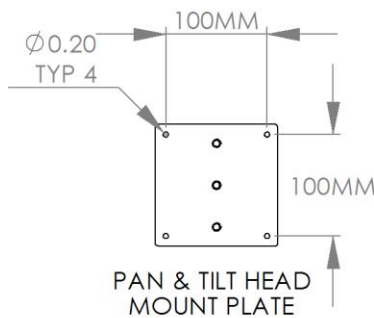
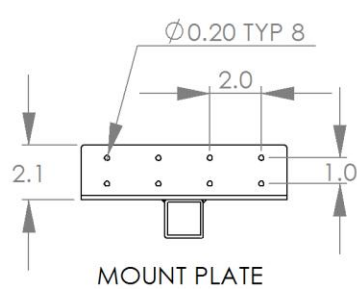
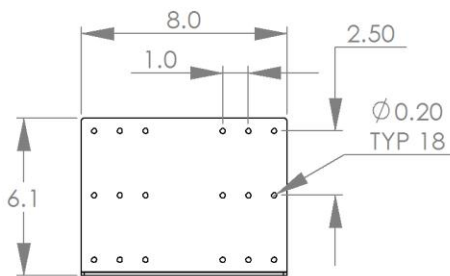
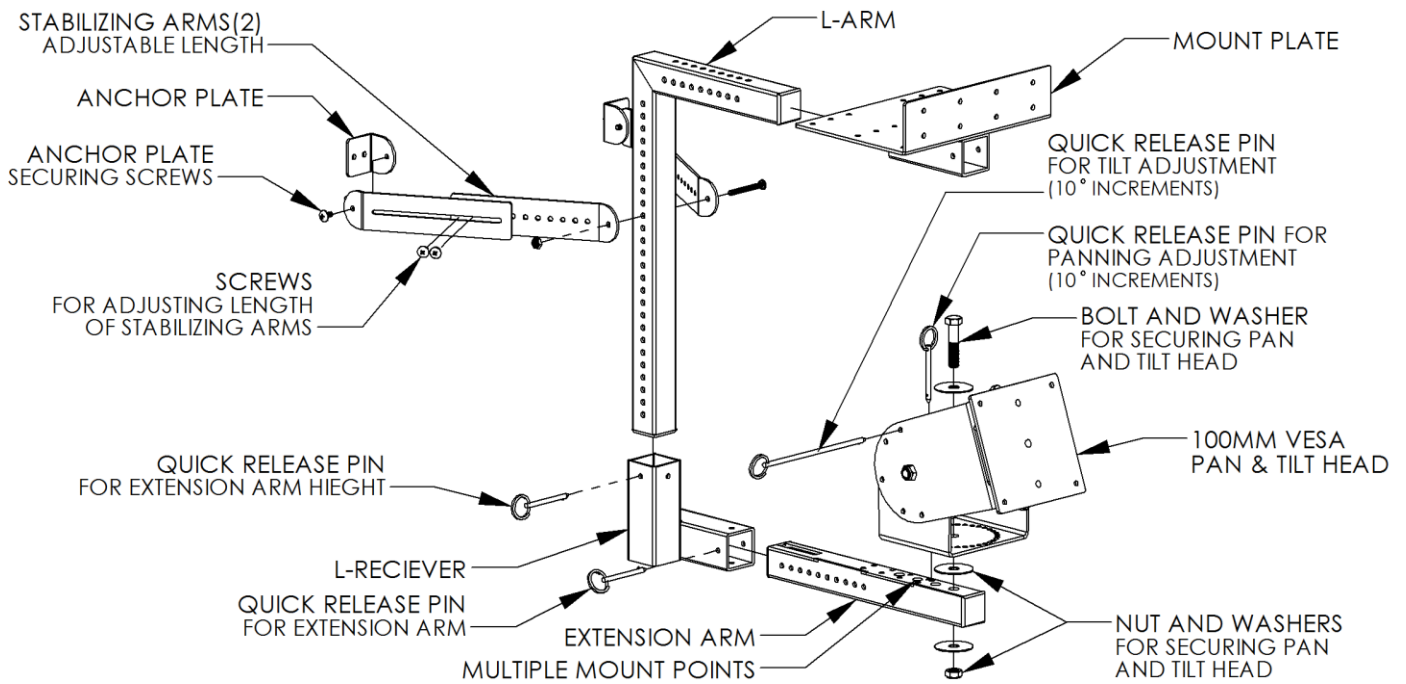

NOTE: 35LB Pendant/Pedestal Mount w/100mm VESA Pan and Tilt Head shown in pendant and pedestal mount configurations. All assemblies with NON VESA compatible pan and tilt heads will appear differently. Also available with 200x200mm AND 200x100mm VESA pan and tilt heads.

35LB Over/Under Counter/Shelf Mount w-100mm VESA Pan & Tilt Head PN 80970

PRODUCT SPECIFICATIONS

- This unconventional yet innovative design solves several mounting problems with a single system. This mounting system allows screens or enclosures to be positioned at multiple locations over or under any standard stainless steel shelf or counter top found in commercial kitchens.
- Three telescopic arm assemblies work together to allow the height of the pan and tilt head to be placed at numerous different positions after the mounting plate has been installed.
- Features six-way adjustability that can be securely locked into any position without tools.
- The telescopic arms feature multiple positioning holes at 1" increments that allow the overall length of the arms to be adjusted. This feature allows the screen or enclosure to be pulled out from or pushed back to the edge of the shelf or counter top or raised and lowered as desired for easy repositioning after the mounting system has been installed.
- Includes two stabilizing arms add structural bracing and can be adjusted after the mounting is installed.
- This mounting system is made entirely of heavy gauge steel and is finished in a bright, metallic, baked on finish that emulates the look of stainless steel.
- Pan and tilt head supports any 100mm VESA compatible screen. For mounting NON VESA compatible screens please refer to the *Custom Fit Pan and Tilt Heads* page on our website found in the *Other Products* section for the most current list of options. If we don't have a compatible pan and tilt head send us a sample of your screen and we'll create a *Custom Fit* solution for you.
- Pan and tilt head adjusts without tools to lock the screen at any position, side to side, or up and down.
- Pan and tilt head also features biased tilt adjustment of 15° towards each direction and locks into position without tools.
- The length of the assembly can be adjusted in 1" increments and locked in place by simply reinserting the quick release pins.
- The assembly supports screens up to 35lbs.
- Mounting Plate attaches to any flat horizontal or vertical surface.

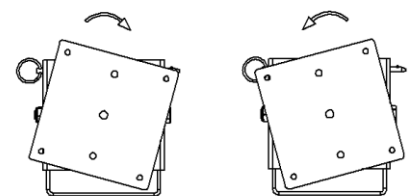
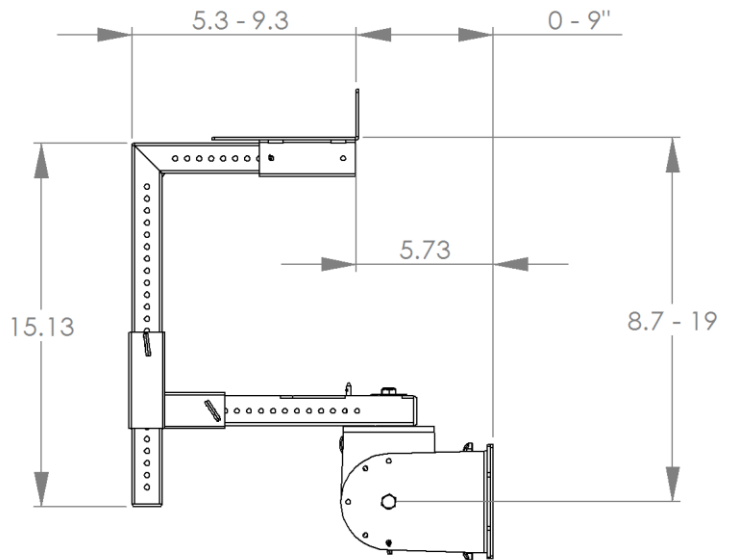

15° BIASED TILT ADJUSTMENT LEFT OR RIGHT

35LB Over/Under Counter/Shelf Mount w-100mm VESA Pan & Tilt Head PN 80970

INSTALLATION INSTRUCTIONS

① INSTALLING BASE PLATE
USE APPROPRIATE FASTENERS
TO ATTACH BASE PLATE TO
MOUNTING SURFACE

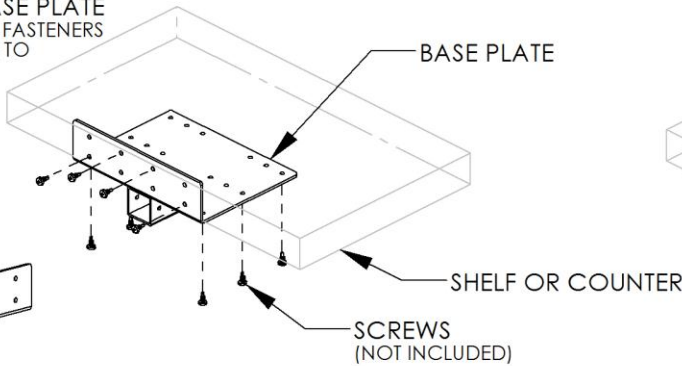

② ATTACHING L-ARM
INSERT L-ARM INTO RECEIVER
ON MOUNT PLATE. INSERT PIN TO
SECURE IN PLACE

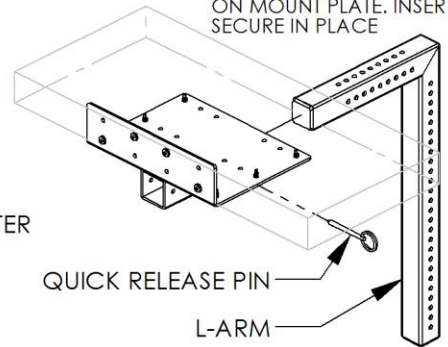

⑤ ATTACH PAN & TILT HEAD
INSERT TO AS SHOWN. SECURE
USING QUICK RELEASE PIN.

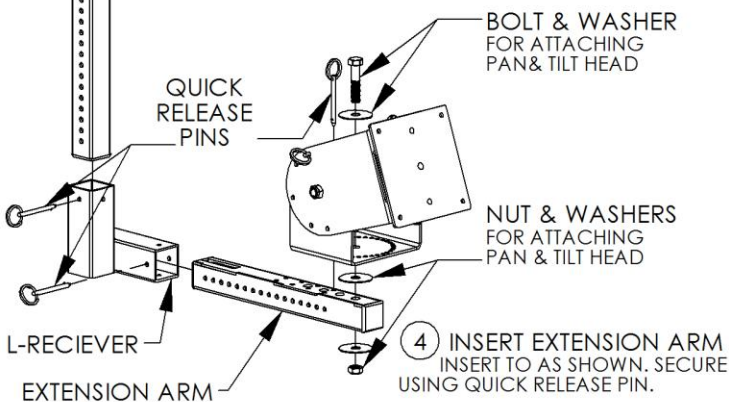

⑥ INSTALL STABILIZING ARMS
USE INCLUDED HARDWARE TO
ATTACH STABILIZING ARMS AS SHOWN.

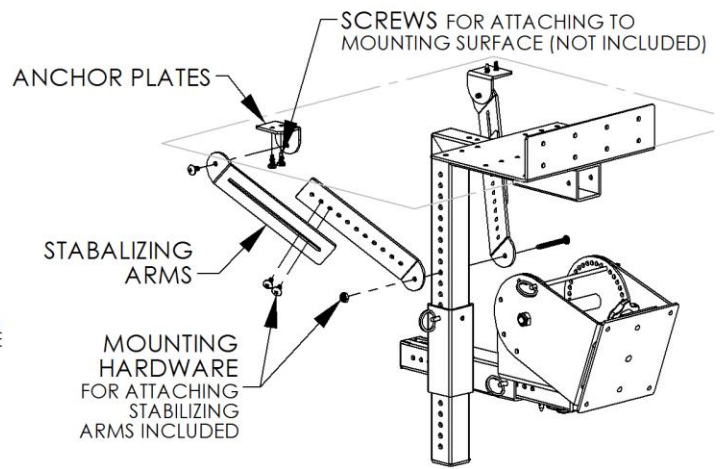

④ INSERT EXTENSION ARM
INSERT TO AS SHOWN. SECURE
USING QUICK RELEASE PIN.

③ ATTACH L-RECEIVER
INSERT TO L-ARM AS SHOWN.
SECURE USING QUICK RELEASE PIN.

MOUNTING CONFIGURATIONS

MOUNTING UNDER
A COUNTER/SHELF

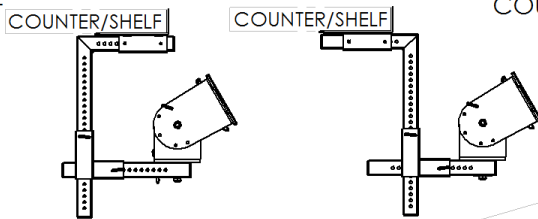

MOUNTING OVER
COUNTER/SHELF

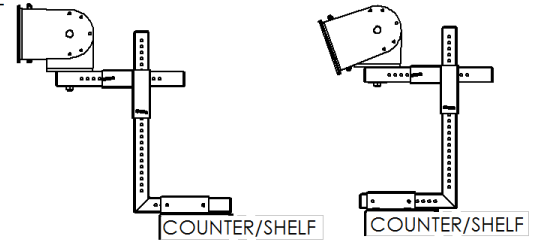

OTHER POSSIBLE CONFIGURATIONS

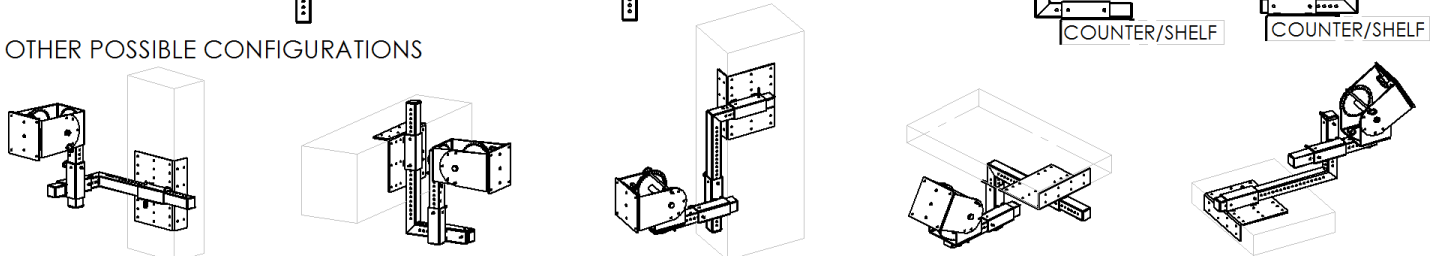

35LB Over/Under Counter/Shelf Mount w-100mm VESA Pan & Tilt Head PN 80970

PRODUCT ASSEMBLIES

- To order this assembly use part number 80970.
- For NON VESA compatible pan and tilt heads use 80970 and add the part number suffix found on the *Custom Fit Pan and Tilt Heads* page on our website. The page can be found listed under the “Other Products” section.
- If the website doesn’t show a suffix that represents your compatible pan and tilt head then send us a sample of your screen and we’ll create a *Custom Fit* solution for you.
- **PQS** offers several mounting options for medium duty applications. All mounts available with 100mm VESA patterns. Most are also available with 200x200 & 200x100mm VESA mounting patterns.

35LB CLASS MOUNTING PRODUCTS:

