

The logo for Practical Quality Systems (PQS) features the letters 'PQS' in a bold, black, sans-serif font. The letters are contained within a white rounded rectangle with a thick black border. This white rectangle is set against a larger blue rounded rectangle that also has a thick black border.

PRACTICAL QUALITY SYSTEMS

Fast Custom Manufacturing - Nationwide Installation Services

Technical Support (818) 993-1022

www.practicalqualitysystems.com

PRODUCT MANUAL FOR UVHM-SM SERIES ASSEMBLIES

UVHM-SM-R6-VESA

PN 80020

A single position side mounting plate with a 6" riser, an 8" arm and a VESA tilt head

UVHM-SM-R3-VESA

PN 80021

A single position side mounting plate with a 3" riser, an 8" arm and a VESA tilt head

UVHM-SM-R6-WS4

PN 80022

A single position side mounting plate with a 6" riser, an 8" arm and a WS4 tilt head

UVHM-SM-R3-WS4

PN 80023

A single position side mounting plate with a 3" riser, an 8" arm and a WS4 tilt head

UVHM-SM-R6-UPMT

PN 80024

A single position side mounting plate with a 6" riser, an 8" arm and a universal printer mounting tray

UVHM-SM-R3-UPMT

PN 80025

A single position side mounting plate with a 3" riser, an 8" arm and a universal printer mounting tray

UVHM-SM-R6-VESA-R6-UPMT

PN 80026

A two position plate with two 6" risers, two 8" arms, a VESA tilt head and a universal printer mounting tray

UVHM-SM-R3-VESA-R3-UPMT

PN 80027

A two position plate with two 3" risers, two 8" arms, a VESA tilt head and a universal printer mounting tray

UVHM-SM-R6-VESA-R3-UPMT

PN 80028

A two position plate with one 6" and one 3" riser, two 8" arms, a VESA tilt head and a universal printer mounting tray

UVHM-SM-R6-WS4-R6-UPMT

PN 80029

A two position plate with two 6" risers, two 8" arms, a WS4 tilt head and a universal printer mounting tray

UVHM-SM-R3-WS4-R3-UPMT

PN 80030

A two position plate with two 6" risers, two 8" arms, a WS4 tilt head and a universal printer mounting tray

UVHM-SM-R6-WS4-R3-UPMT

PN 80031

A two position plate with one 6" and one 3" riser, two 8" arms, a WS4 tilt head and a universal printer mounting tray

TABLE OF CONTENTS

Section	Page
1.1 Identifying, configuring and locating the mount for your application	1
1.2 Basic installation steps	1
2.1 Installing the SM mounting plate	1
2.2 Reattaching the arm(s) to the mounting plate	1
3.1 Basic steps for installing a screen with VESA standard mounting holes	2
3.2 Attaching the VESA tilt head to a VESA standard flat panel monitor, touch screen or terminal	2
3.3 Basic steps for installing a screen such as a WS4 which has a proprietary tab or keyhole mounting system on the back of the screen	2
3.4 Basic steps for installing a printer tray	2
4.1 Attaching a tilt head or printer tray to the end of the arm	2
4.2 Adjusting the side to side position of a tilt head or printer tray	3
5.1 Adjusting the up and down position of the tilt head	3
5.2 Locking the tilt head position for the long term	3
6.1 Adjusting the tilt head stop	4
7.1 Adjusting the side to side position of the arms on top of the riser	4
8.1 Adjusting the riser stop	4
9.1 Installing and adjusting the UPMT (Universal Printer Mounting Tray)	5
9.2 Printer tray cabling tips for assemblies with risers	5
9.3 Monitor or touch screen cabling tips for assemblies with risers	5

LIST OF FIGURES

Figure	Page
1 – P1 and P3 mounting plates and positions	5
2 – UVHM-SM-R6-VESA	6
3 – An 8” arm and VESA tilt head	6
4 – An 8” arm and WS4	7
5 – An 8” arm and a UPMT	7
6 – UVHM-SM-R6-VESA	8

PRODUCT MANUAL FOR UVHM-SM SERIES ASSEMBLIES

1.1 Identifying, configuring and locating the mount for your application

PLEASE NOTE: these instructions are for multiple similar product assemblies, refer to the “List of Figures” page to locate an exploded view of the assembly that you are using.

All of these assemblies are SM (Side Mount with Riser) types which include either the P1 mounting plate which supports one riser with one arm, or the P3 mounting plate which can support either one or two separate risers with arms (See Figure 1).

1.2 Basic installation steps

1. Preassemble the mount for the desired configuration with the tilt head and/or printer tray attached, but without the equipment installed (See Figure 2).
2. Hold the assembly with the mounting plate against the mounting surface to determine its best location.
3. Pivot the arms so that they can be rotated through their entire range of motion and does not conflict with the surrounding surfaces. Be sure to take into consideration the additional space that the equipment will need once it is attached to the end(s) of the arm(s).
4. Consider where the riser stop should best be located to permit the optimum range of motion. If the riser stop position needs to be adjusted, refer to section 8.1 and adjust the riser stop position as needed before attaching the mounting plate to the mounting surface.
5. Once the mounting location has been determined, mark the locations for the fasteners through the holes on the mounting plate. Follow the installation instructions that are appropriate for your application.

2.1 Installing the SM mounting plate

1. The SM mounting plates (See Figure 1) feature either one or three repeating patterns of 1/4"-20 threaded holes for the insertion of the four mounting screws that attach the SB (Stand Off) brackets with the risers and arms to the mounting plate. The mounting screw pattern allows the SB brackets with the risers and arms to be removed and remounted to the plate. The risers provide the first pivot point for the arms allowing them a full range of side to side motion. The arms are attached to the top of the riser with a 5/16" bolt that is secured with thread locking compound and is not intended to be removed or adjusted in the field.
2. Remove the tilt heads and/or the printer tray from the arm(s).
3. Remove the arm(s) with the SB brackets from the mounting plate.
4. Securely attach the mounting plate to the mounting surface with four or more fasteners that are appropriate for the mounting surface material.

2.2 Reattaching the arm(s) to the mounting plate

1. The SB brackets with the riser(s) should still be attached to the ends of the arm(s). Hold the riser so that the arm is on top, and the SB bracket is on the bottom, and align the holes in the SB bracket with one of the patterns of threaded holes on the mounting plate.
2. Loosely install the four 1/4"-20 Philips securing screws through the SB bracket (See Figure 6), and into the threaded holes in the P3 mounting plate. Do not fully tighten the screws until all of the screws are threaded into the plate.

PRODUCT MANUAL FOR UVHM-SM SERIES ASSEMBLIES

3.1 Basic steps for installing a screen with VESA standard mounting holes

1. Remove the tilt head from the end of the arm (See Figure 6).
2. Install the mounting plate complete with the riser(s) and arm(s).
3. Install the VESA tilt head to the back of the screen.
4. Install the tilt head and the screen together as a unit onto the end of the arm.

3.2 Attaching the VESA tilt head to a VESA standard flat panel monitor, touch screen or terminal

1. Place the unit with the screen facing down on a smooth flat surface and remove the VESA mounting screws from the back of the monitor. If the screws are not present, refer to the unit manual, or contact the manufacturer to obtain the correct type and length of screws.
2. Lay the VESA tilt head flat on top of the back of the screen, and align the four holes in the VESA tilt head with the pattern of four threaded holes on the back of the screen.
3. Loosely install the four screws through the VESA tilt head and into the threaded holes on the back of the screen. Do not fully tighten the screws until all of the screws are threaded into the back of the screen.

3.3 Basic steps for installing a screen such as a WS4 which has a proprietary tab or keyhole mounting system on the back of the screen

1. Remove the tilt head from the end of the arm.
2. Install the mounting plate complete with the riser(s) and arm(s).
3. Install the tilt head on the end of the arm (See Figure 4).
4. Install the screen onto the tilt head. If you are installing a WS4 terminal, use the same small thumb screws which secured the terminal to the base, to secure it to the tilt head.

3.4 Basic steps for installing a printer tray

1. Remove the printer tray from the end of the arm.
2. Install the mounting plate complete with the riser(s) and arms.
3. Install the printer tray on the end of the arm (See Figure 5).
4. Install the printer on the printer tray.

4.1 Attaching a tilt head or printer tray to the end of the arm

1. Lay the anti-slip washer on the top of the end of the arm (See Figure 6).
2. Check that the bottom of the tilt head is flat, and that the four point tilt knobs are tightened enough so that the tilt head cannot move easily.
3. Carefully lift the monitor or printer tray and center the bottom hole of the tilt head or tray over the hole in the end of the arm.
4. Gently lower the monitor until the bottom of the tilt head is resting slightly on the end of the arm. Do not release your grip on the monitor or printer tray.

PRODUCT MANUAL FOR UVHM-SM SERIES ASSEMBLIES

5. Hold the five-pointed knob so that the threaded shaft is pointing up and it is under the end of the arm. Guide the knob shaft up through the hole in the end of the arm, and through the anti-slip washer until it contacts the center of the threaded hole in the bottom of the tilt head or printer tray.
6. Carefully turn the knob to thread it into the bottom of the tilt head or tray until the bottom of it is pulled snugly against the top of the end of the arm.
7. Verify that the end of the knob's threaded shaft can be seen inside of the nut on the bottom of the tilt head or printer tray. Do not release your grip on the monitor until you have verified that the tilt head or printer tray is correctly attached to the end of the arm.

4.2 Adjusting the side to side position of a tilt head or printer tray

1. Carefully and firmly grasp the monitor or printer at the top center of the unit to support its entire weight.
2. Slightly loosen the large five point knob below the end of the arm just enough so that the tilt head or printer tray will turn (See Figures 3, 4 and 5).
3. While still firmly holding the monitor or printer, slowly rotate it to the desired position and then tighten the locking knob securely.

5.1 Adjusting the up and down position of the tilt head

1. Carefully and firmly grasp the monitor at the top center of the screen to support its entire weight.
2. Slightly loosen both of the four point knobs on both sides of the tilt head just enough so that the monitor can be moved up and down slightly (See Figure 3).
3. While still firmly holding the monitor, slowly raise or lower it to the desired position, and then tighten both of the locking knobs securely.

5.2 Locking the tilt head position for the long term

In most cases, firm tightening of the three locking knobs on the tilt head will sufficiently hold the desired side to side and up and down position of the screen. If your application requires additional security to hold the desired screen position, the tilt head can be more securely locked by slightly tightening the tilt head locking screws.

PLEASE NOTE: if the factory setting of the locking screws is changed, they must be reset to return the tilt head to normal function.

Follow the steps below to lock the tilt head in place for the long term:

1. Adjust the tilt head as described in the instructions to hold the screen at the desired position.
2. Tighten the three locking knobs as firmly as possible using only your hands (See Figure 3).
3. Using a standard Philips type screwdriver, gently tighten the two locking screws on the sides of the tilt head, and the single locking screw on the end of the arm under the bottom of the tilt head.

To reset the original position of the tilt head locking screws:

1. Support the entire weight of the screen. Doing one at a time, carefully loosen the locking screws until only three threads of the end of the screw shaft can be seen protruding through the metal next to the anti-slip washer (See Figure 3).
2. The correct length of the protruding end of the locking screw is set when there is no weight on the tilt head, and the knob is tightened slightly until there is no space between the metal surfaces and

PRODUCT MANUAL FOR UVHM-SM SERIES ASSEMBLIES

the anti-slip washers. With this knob pretension set, the protruding end of the locking screw should be set just back of where it would contact the opposing metal surface by approximately 1/32.”

6.1 Adjusting the tilt head stop

The tilt head stop keeps the tilt head from doing a full rotation around the end of the arm (See Figure 2). This protects the cabling that connects to the equipment from being wrapped around the tilt head and possibly becoming damaged. The tilt head is set at the factory to prevent the arm from being rotated one entire revolution to the left. If this setting does not work for your application, the riser stop can be easily removed from the bottom of the tilt head with a Philips screwdriver and installed on the other side.

7.1 Adjusting the side to side position of the arms on top of the riser

1. Slightly loosen the three point knob on the side of the riser cap enough so that the arm will move freely (See Figure 2).
2. Carefully move the equipment with the arm to the new position and then retighten the five point knob to secure the arm.

8.1 Adjusting the Riser stop

The riser stop keeps the arm from doing a full rotation around the riser (See Figure 2). This protects the cabling that connects to the equipment from being wrapped around the riser and possibly becoming damaged. The riser stop is set at the factory to prevent the arm from being rotated one entire revolution to the left. If this setting does not work for your application, the riser stop can be easily adjusted.

Adjusting the riser stop for the “optimum range of motion:”

1. Consider the entire range of motion possible for the arms that support the equipment.
2. Establish all of the best locations where the equipment will be moved to and used.
3. This is the “optimum range of motion” for your application.
4. If unrestricted, the arm would make a complete circle around the riser. The “optimum range of motion” occupies at least one half of the circle. The riser stop should be placed exactly opposite to the middle of the optimum range on the other half of the circle.

To adjust the position of the riser stop:

1. Disconnect any cabling that is connected to the equipment.
2. Using a Philips screwdriver, remove the riser stop screw and plastic spacer from the side of the riser (See Figure 2).
3. Using a Philips screwdriver, slightly loosen the riser locking screw on the bottom of the SB bracket just enough so that the riser can be rotated.
4. Grasp the riser carefully and slowly rotate it the minimum amount so that the stop is located on the opposite side of the middle of the “optimum range of motion” for your application.
5. Carefully retighten the riser locking screw just enough to keep the riser from turning under normal use.
6. Reinstall the riser stop screw and spacer in the side of the riser.
7. Test the range of motion and adjust as necessary.

PRODUCT MANUAL FOR UVHM-SM SERIES ASSEMBLIES

9.1 Installing and adjusting the UPMT (Universal Printer Mounting Tray)

The width of the UPMT will expand to support printers from 5" to 9 1/2" wide. To extend or retract the sides of the tray, turn one of the small round knobs on either of the sides on the middle of the tray until the desired width is adjusted (See Figure 5).

The tray will tilt from the level position to 30 degrees forward. To adjust the forward tilt, carefully loosen the two three-pointed knobs which are on each side of the front of the tray. Raise or lower the rear of the tray to the desired tilt angle and tighten the knobs to secure the tilt position. Be advised, some types of printers will erroneously indicate that they are low on printing paper when they are tilted too far forward.

9.2 Printer tray cabling tips for assemblies with risers

Route the data and power cables and connect them loosely to the printer. After testing your printer for correct operation, use small plastic cable ties, or hook and loop ties, to attach the cables to the metal tie loops at the rear of the printer tray, be sure that the cable connectors will not be strained when the printer repositioned. Then with more ties, form the printer cables into a single bundle to create a cable leash that extends from the rear of the printer tray, to the tie point on the top of the riser cap (See Figure 2), and then down to a point near the mounting plate location. Be sure to leave enough slack cable so that the printer can be moved through its entire range of motion around the end of the arm, AND so that the arm can be moved around the top of the riser cap.

9.3 Monitor or touch screen cabling tips for assemblies with risers

Route the data, power, and other cables and connect them loosely to the screen. After testing your screen for correct operation, attach the cables to the plastic roller behind the middle of the tilt head, so that the cable connectors will not be strained when the screen is repositioned. Using small plastic cable ties, or hook and loop ties, form the cables into a single bundle to create a cable leash that extends from the rear of the tilt head, to the tie point on the top of the riser cap, and then down to a point near the mounting plate location. Be sure to leave enough slack cable so that the equipment can be moved through its entire range of motion around the end of the arm, AND so that the arm can be moved around the top of the riser cap.

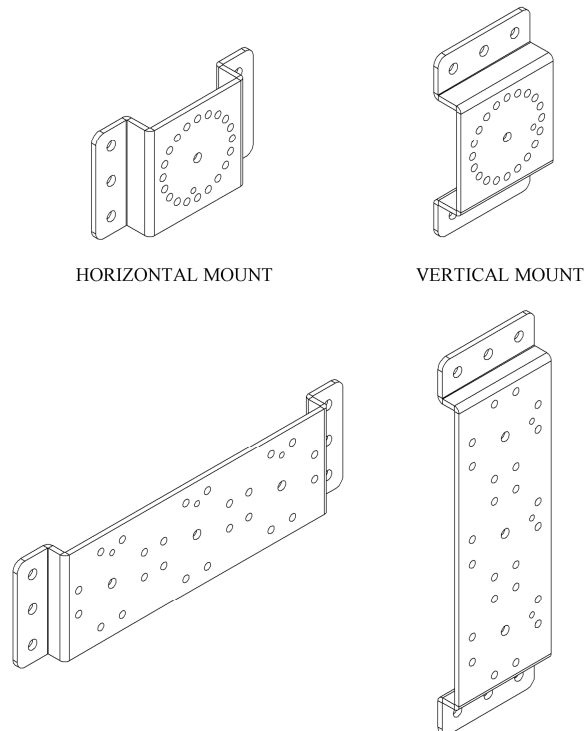

Figure 1 - P1 and P3 mounting plates and positions

PRODUCT MANUAL FOR UVHM-SM SERIES ASSEMBLIES

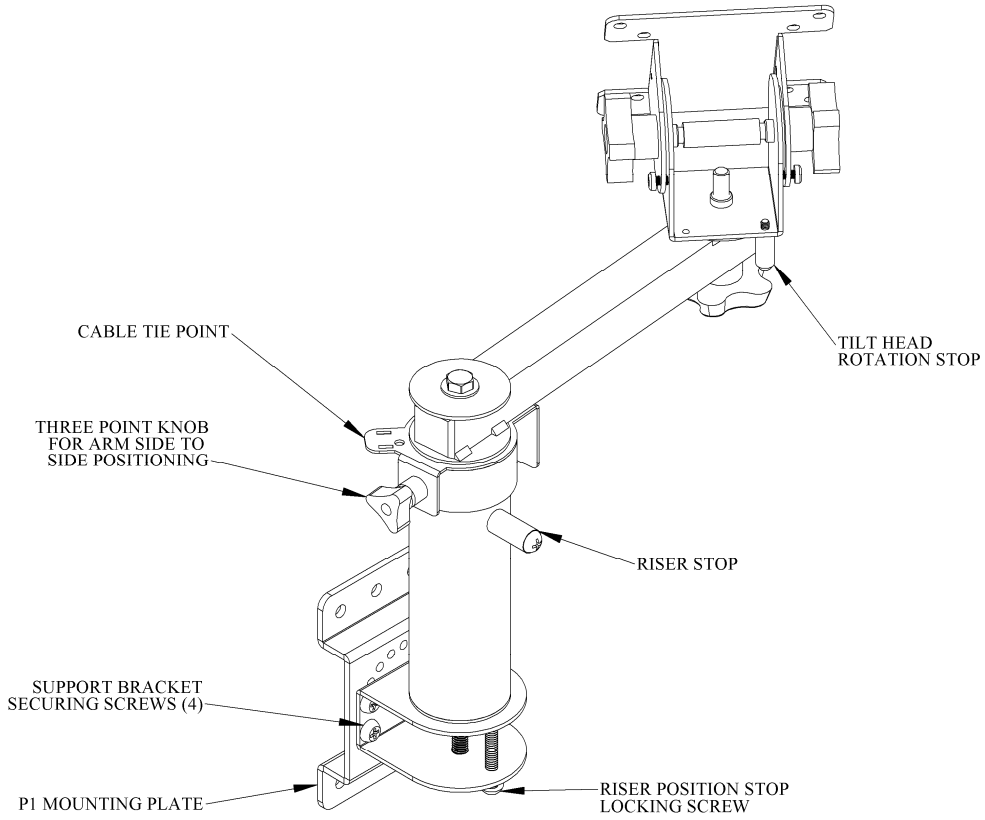

Figure 2 - UVHM-SM-R6-VESA

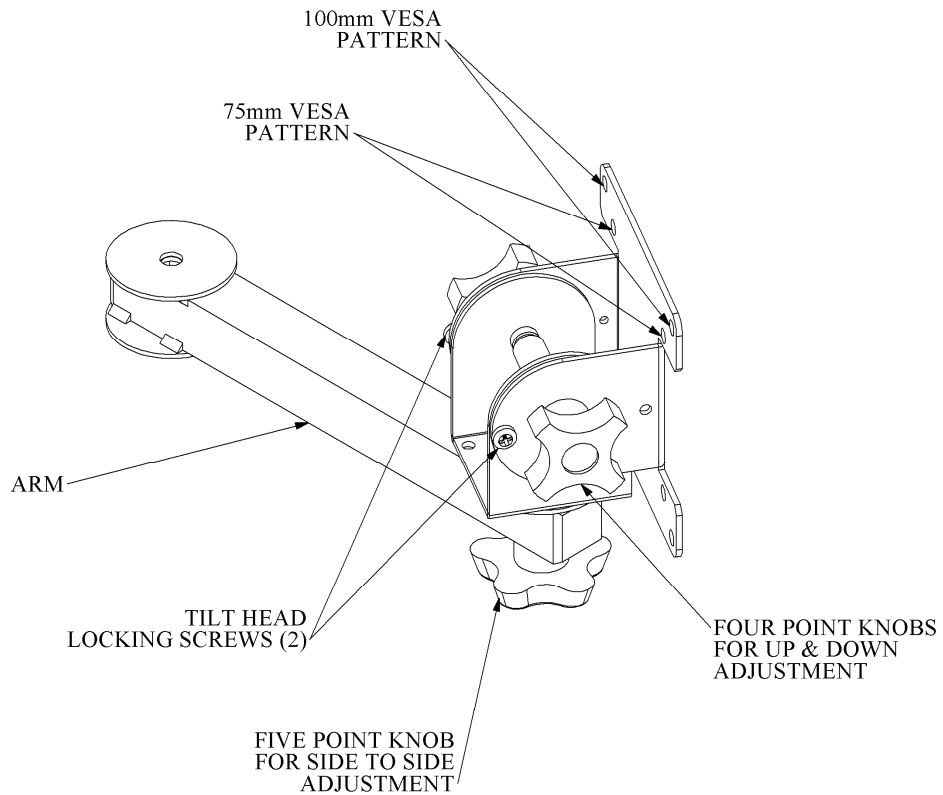

Figure 3 - An 8" arm and VESA tilt head

PRODUCT MANUAL FOR UVHM-SM SERIES ASSEMBLIES

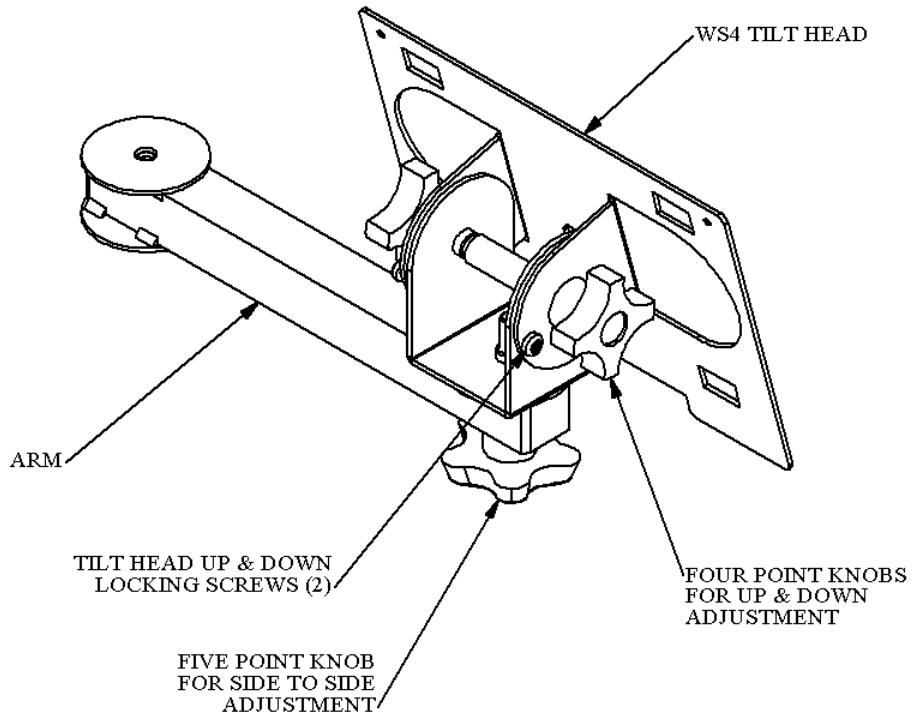

Figure 4 - An 8" arm and WS4

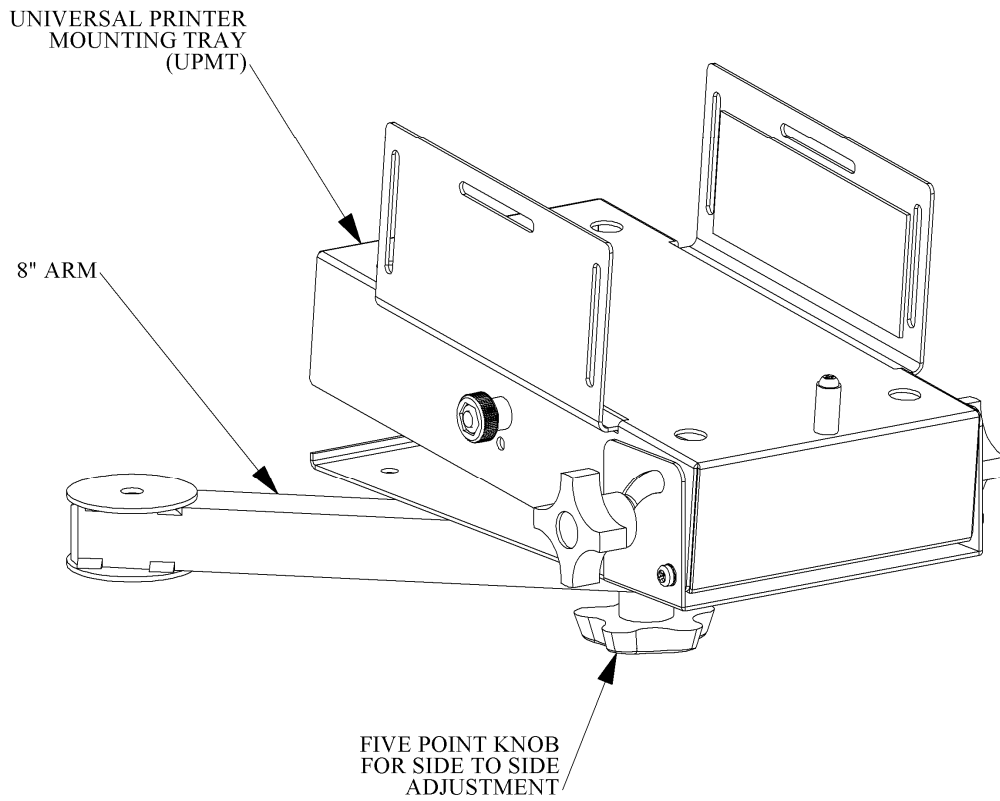

Figure 5 - An 8" arm and a UPMT

PRODUCT MANUAL FOR UVHM-SM SERIES ASSEMBLIES

UVHM-SM-R6-VESA: PN 80020

A single position side mounting plate with a 6" riser, an 8" arm and a VESA tilt head

ITEM#	PART#	DESCRIPTION	QTY.
1	70003	BOLT, 5/16-18 x 1.75" LG HEX HD	1
2	70038	WASHER, .75" ID x .312" ID x .05" Thk	2
3	70011	SQUARE END PLUG	2
4	70018	SPACER, Plastic, .50 ODx.257 IDx.375LG	1
5	70009	KNOB, 1/4-20 x .50 LG, TRI TIP	1
6	70019	SCREW, PHILLIPS RND HD 1/4-20x1.75"LG	2
7	70014	SPACER 1/2" OD x 5/16" ID x 1-1/8" L	1
8	50127	UVHM SINGLE MOUNT PLATE	1
9	50046	UVHM STANDARD STANDOFF BRACKET	1
10	70061	BOLT, .313-18 x 2.25" LG	1
11	70035	SLEEVE, 1/2" OD x 5/16" ID x 1-1/2" L	1
12	70023	KNOB, 5/16-18 x 1.75" L 4 POINT	2
13	70020	SCREW, PHILLIPS Bttn Hd, 10-32x1/4"	2
14	50048	8" MOUNT ARM	1
15	50157	RISER CAP	1
16	70000	BOLT, 1/4-20 x .50" LG, RND PHILLIPS	5
17	50162	UVHM 6" RISER ASSEMBLY	1
18	70022	SILICONE WASHER	3
19	50030	VESA TILT HEAD	1
20	50028	TILT HEAD BASE	1
21	70021	KNOB, 5/16-18 x 2.0" LG, 5 POINT STAR	1

For other UVHM-SM assemblies please refer to the UVHM-SM product manual cover page.

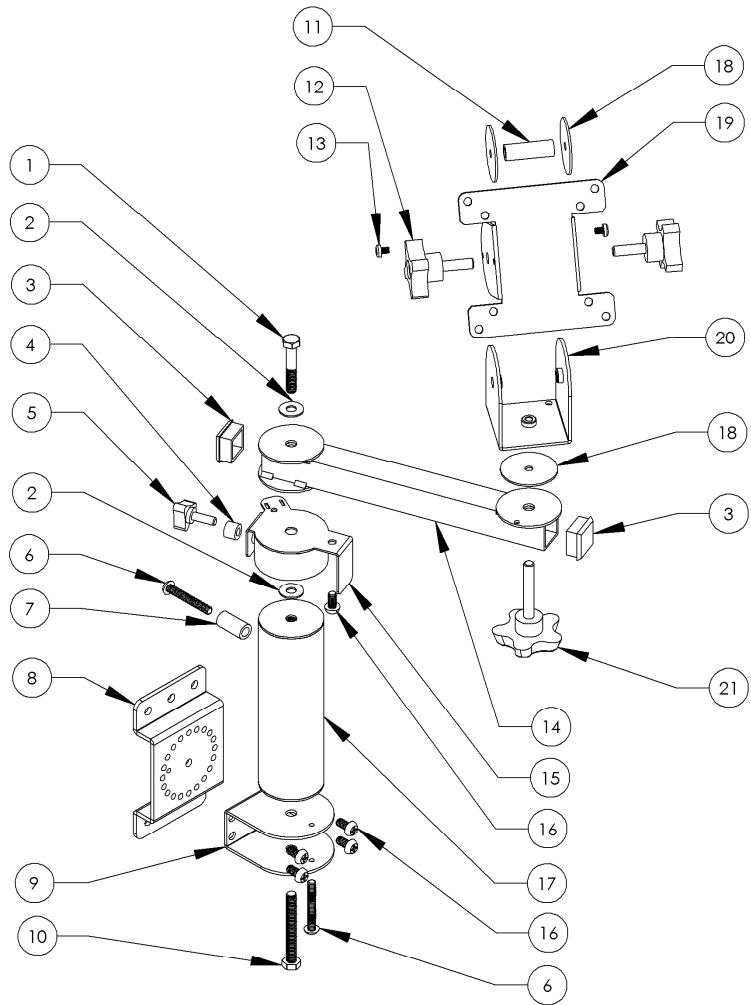

Figure 6 - UVHM-SM-R6-VESA