

Technical Support (818) 993-1022

www.practicalqualitysystems.com

FPAM PRODUCT MANUAL

FPAM PN 80500
VESA compatible Flat Panel Accessory Mount

TABLE OF CONTENTS

Section	Page
1.1 Using the hardware kit to attach bump bars or other equipment to the FPAM mounting plate	1
1.2 Installing a bump bar below the front of the screen	1
2.1 Attaching a UVHM VESA tilt head to the FPAM and screen	2
2.2 Attaching a MICROS RDC controller or similar unit to the FPAM	2
3.1 Installing the assembled screen and FPAM with attached equipment to a UVHM arm	2

LIST OF FIGURES

Figure	Page
1 – FPAM	3
2 – FPAM with Bump bar attached	3

Installation Instructions for the FPAM (Flat Panel Accessory Mount)

FPAM **PN 80500** Micros p/n: 600526-038 (PQS p/n: FPAM-K-MK1)
VESA compatible Flat Panel Accessory Mount

NOTE: If you are using the FPAM with a UVHM mounting system, please refer to the UVHM installation instructions to correctly install the mount.

NOTE: If you are NOT installing a bump bar, begin with the section 2.1 titled “Attaching a UVHM VESA tilt head to the FPAM and screen.”

NOTE: The FPAM mounting plate can be attached to the rear of any 75 or 100mm VESA compatible monitor or touch screen. It can be used to support accessories such as bump bars, card swipes, speakers, etc. The mounting plate can be laid across the VESA pattern and rotates to position the plate so that it can be used to support accessory items below, above, and to either side of the screen.

1.1 Using the hardware kit to attach bump bars or other equipment to the FPAM mounting plate

1. Examine the contents of the optional FPAM hardware kit (See Figure 1). Note that the arms and tee tangs of the hardware kit can be custom configured to attach a wide variety of bump bars, card swipes, speakers, etc. to the mounting plate.
2. Determine the configuration of the hardware kit that works best to secure your bump bar or other equipment to the mounting plate.
3. Assemble the adjustable arms with or without the tee tangs to align with the chassis screws of your particular bump bar or other equipment.

1.2 Installing a bump bar below the front of the screen

1. Place the monitor or touch screen with the screen facing down on a smooth flat surface and remove the VESA mounting screws from the back of the monitor. **PLEASE NOTE:** you may need to obtain longer screws and/or some small washers to connect the VESA tilt head and the FPAM to the back of the screen.
2. If you are using a monitor speaker bar, install it to your screen before proceeding.
3. Place the bump bar so that it is facing down, and the top of the bump bar is located directly against the bottom center of the screen.
4. Place the FPAM mounting plate on top of the center of the back of the screen and bump bar.
5. Align the four VESA mounting holes on the back of the screen with two of the slots on the FPAM mounting plate. Loosely insert two VESA mounting screws through the slots in the FPAM mounting plate and into the VESA mounting holes on the back of the screen.
6. Assemble the hardware kit to create two arms so that the slots in the arms or tee tangs align with the chassis screw holes on the sides, bottom, or back of the bump bar (See Figure 2). The other ends of the arms align with the slots on the FPAM mounting plate.
7. Carefully remove the chassis screws on the bump bar and then re-install the screws through the slots in the tee tangs or arms to attach them to the bump bar. **NOTE:** some small washers and/or longer screws may be needed to correctly attach the arms or tee tangs to the bump bar chassis screw holes.
8. Align the opposite ends of the arms with the slots on the FPAM mounting plate and secure them with screws and lock nuts from the hardware kit.
9. Remove the two screws which are loosely holding the FPAM mounting plate to the back of the screen.

Installation Instructions for the FPAM (Flat Panel Accessory Mount)

2.1 Attaching a UVHM VESA tilt head to the FPAM and screen

1. Place the VESA tilt head on top of the FPAM mounting plate. Align the VESA mounting holes in the tilt head with the slots in the FPAM mounting plate and the four VESA mounting holes on the back of the screen.
2. Loosely insert all four screws through the holes in the tilt head, through the slots in the FPAM, and into the VESA mounting holes in the back of the screen and verify that everything is properly aligned.
3. Carefully tighten the VESA mounting screws to secure the tilt head and the FPAM with the attached equipment to the back of the screen.

2.2 Attaching a MICROS RDC controller or similar unit to the FPAM

1. Install the hook and loop strapping through the top slot of the FPAM bracket and around the back of the bracket to the first empty slot above the VESA tilt head. The controller unit can be installed directly against the tilt head by routing the strapping around the roller within the middle of the back of the tilt head, and around the strapping screw at the top of the back of the tilt head.
2. Once the hook and loop strapping is installed through the slots in the FPAM mounting plate, place the controller unit so that the cable connections are oriented towards the sides of the FPAM bracket.
3. Pull the hook and loop strapping down snugly and then press the mating faces of the strapping firmly together to secure the controller unit to the FPAM mount.
4. If you are using a bump bar, verify that it is aligned properly with the bottom of the screen, and make any final adjustments to the arms and tee tangs.

3.1 Installing the assembled screen and FPAM with attached equipment to a UVHM arm

1. Place an anti-slip washer on top of the single washer end of the UVHM arm. Carefully lift the screen with the FPAM and equipment, and align the hole in the end of the top of the arm with the threaded hole on the bottom of the VESA tilt head. Install the five point knob through the bottom of the arm, through the anti slip washer, and into the threaded hole located in the bottom of the tilt head. Tighten the five point knob snugly to remove excess free play between the tilt head and the end of the arm.
2. Turn the screen so that you can access the cable connections on the sides of the controller unit and connect the associated cables for the power, touch screen, network data, bump bar, etc.
3. Rotate the completed assembly to the desired side to side position. Tighten the clamping knobs on the top of the SB (Stand Off) bracket at the mounting plate and at the bottom of the VESA tilt head to secure those positions. Tilt the completed assembly to the desired viewing angle and use the two four-point knobs on the sides of the VESA tilt head to secure the monitor at the desired tilt position.

Installation Instructions for the FPAM (Flat Panel Accessory Mount)

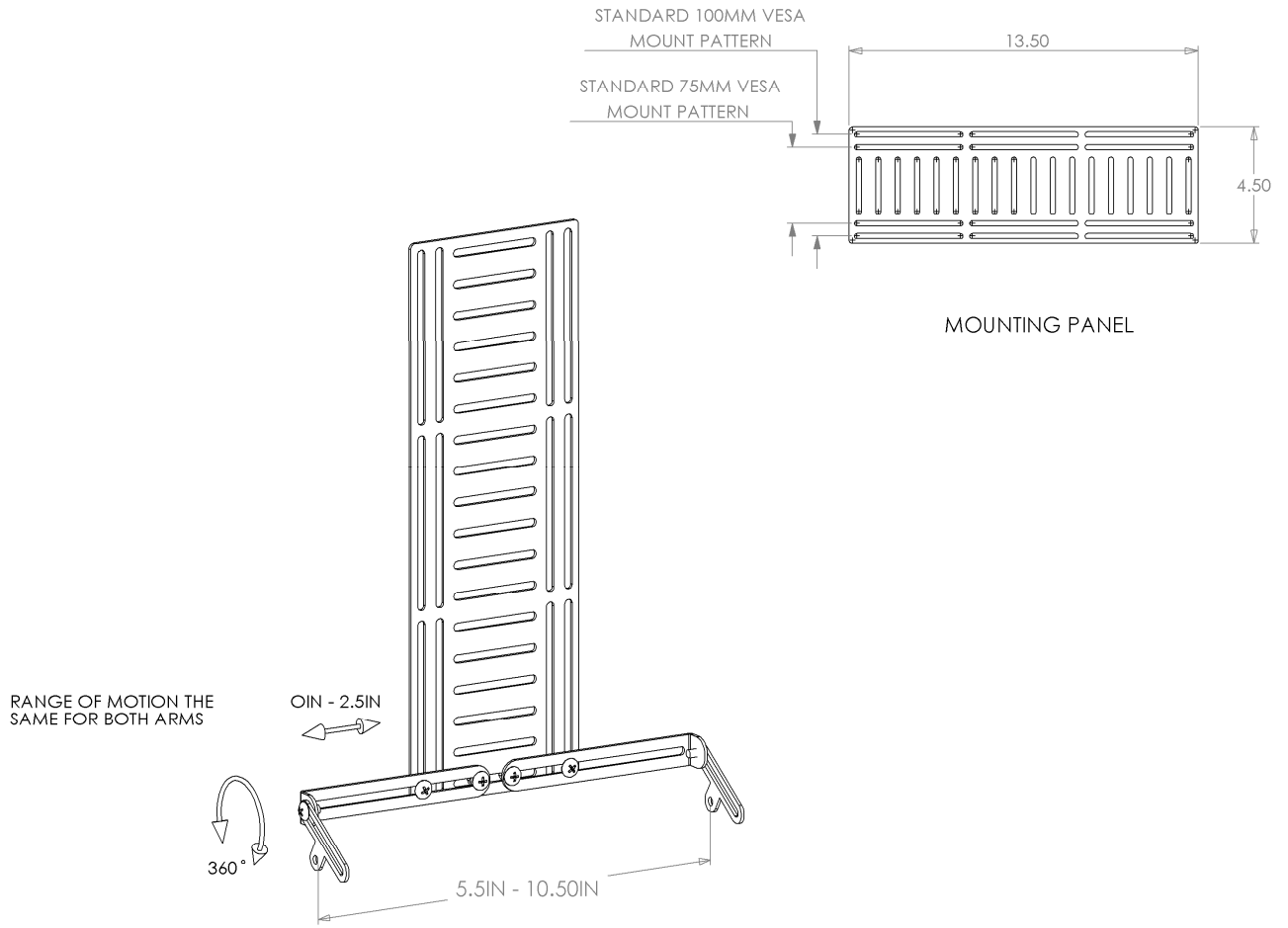

Figure 1 - FPAM

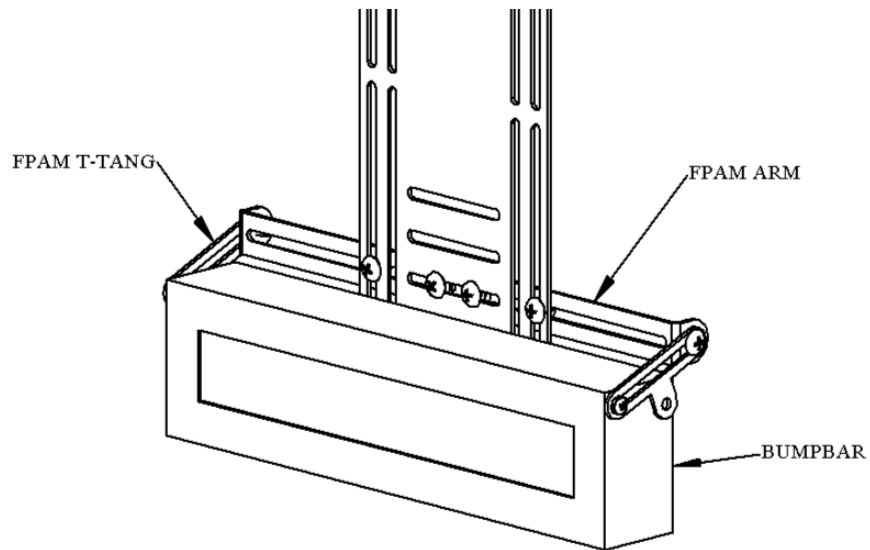

Figure 2 - FPAM with bump bar attached