

Shelving System Group 2 User Manual:

This manual is for the following product assemblies:

- 81360 Shelving System 45"W, Work Table, Lower Shelf, Upper Shelf, Upper Cabinet
- 81361 Shelving System 72"W, Work Table, Lower Shelf, Upper Shelf, Upper Cabinet



PN 81360



PN 81361

Shelving System Group 2 User Manual:.....1

Introduction3

Safety Information.....4

Tools Needed5

How to use Self Tapping Screws.....6

Basic Steps.....7

 Unpack the Shelving System.....7

 Inspect the Shelving System, Accessories, and Hardware Kits.....7

 Installing Lower Shelf on the wall with the Wall Mount Brackets7

 Attaching the wall mount brackets to the wall8

 Installing the Work Table on the Wall Mount Brackets11

 Installing the Vertical Shelf Standards above a Work Table12

 Installing shelves on Vertical Shelf Standards13

 If your Shelving System has an Upper Cabinet: Upper Cabinet Overview15

 Pre assembly for the Upper Cabinet.....16

 Install the cabinet top.....17

 Installing the Upper Cabinet sides and back section20

 Installing the bottom of the Upper Cabinet.....21

 Installing the 72" W Upper Cabinet Doors Assemblies23

 Installing the 45" W Upper Cabinet Doors Assemblies24

Optional Steps25

 Adjusting the Height of a Shelf.....25

 Installing cabling through cable path openings on a Work Table.....26

 Installing flexible grommet material around cable path openings27

Product Short Descriptions28

Product Specifications 45" W x 92"H x 30"D29

Product Specifications 72" W x 92"H x 30"D30

Engineering Drawing Reference Notes:30

Identifying External Components.....31

Warranty Information34

Service and Support35

Introduction

This manual is designed to assist you in unpacking, assembling, installing, and using your PQS equipment safely and efficiently. Please refer to the cover of this manual for the applicable configurations.

PQS products are modular and can be configured in numerous ways for a variety of applications. This manual contains information about the general setup of your PQS product, but cannot cover the multitude of configurations possible with this modular system. Please refer to the table of contents to reference the part or procedure that is most closely associated with your desired setup.

If you are viewing this manual in electronic format:

Using the 'bookmarks' tool in Adobe Acrobat is an efficient way to navigate this PDF document. Click the bookmarks tab to the left of the screen to view thumbnails of each page. The table of contents items are linked to their respective sections. Clicking on a TOC item will bring you to the appropriate section. You can also use ctrl+ f to bring up a search dialogue so you can search for key words or part numbers.

The information in this manual is subject to change without notice. PQS is not liable for errors contained herein or for incidental or consequential damages in connection with the furnishing, performance, or use of this material.

Because PQS products are always being improved, the illustrations and descriptions in this manual may differ from the products you receive.

This document contains proprietary information that is protected by copyright. No part of this document may be photocopied, reproduced, or translated into another language without the prior written consent of PQS.

©2009 Practical Quality Systems. All rights reserved. PQS is a registered trademark. All other trademarks belong to their respective companies.

Common notifications in this manual:

Messages like those below indicate special information:



WARNING: Failure to follow instructions that appear in these cautionary boxes could result in the injury or death of personnel and/ or damage to equipment and loss of data.



Tip: Instructions that appear next to a light bulb icon are designed to make the assembly of your unit go more easily and to help you avoid losing time due to mistakes.

Safety Information

This part of the manual provides an overview of safety guidelines to be observed when assembling, installing and using your PQS equipment.

Keep a printed copy of this User's Manual, especially the following safety information, in or near the Enclosure, Work Table, or Shelving System .

WARNINGS

- Improper use of this product may lead to serious injury or death. Read and understand all instructions prior to the assembly or use of this product.
- Be advised that some parts of the product components may have sharp edges, please handle all pieces carefully.
- Hire a professional electrician to connect permanent power circuits to equipment assemblies. It is advised against to route electricity to or within the unit without expert knowledge.
- Have each unit individually grounded to the Telecommunication Ground Circuit (TGC) or signal reference grid to protect equipment and personnel from dangerous electrical charges. If you do not know how to do this, hire a professional electrician.
- If you will be housing electronics in a PQS Enclosure or Cabinet, make sure that there is adequate ventilation to keep your electronics at a safe operating temperature. Refer to the section titled "Modular Ventilation Systems Overview" for further reference.
- Be sure to use sufficient personnel to move the products safely. Most assembly and installation steps will require more than one person to comfortably and safely complete the task. Do not attempt to move large parts by yourself. Obtain adequate assistance to prior to moving heavy parts or hire professional equipment riggers if necessary.
- Make sure loose items are removed from within the unit prior to moving it. Items shifting within assemblies can cause instability.
- Move equipment on installed casters with extreme care. Sudden changes in direction, forces, or the surface over which the product is being moved can cause the unit to fall over. Never push on the sides. Casters are only for moving your unit to the desired location. Once in place, attach the leveling feet and secure the unit in place.
- A standalone unit should be level, stable, and anchored to the floor.
- Two or more units can be coupled together to enhance their stability. Even when coupled, anchor each individual unit to the floor and wall.
- Consult you local building codes for seismic regulations regarding securing heavy equipment and ensure that your Enclosure, Work Table, or Shelving System is secured according to your local laws.
- Before loading equipment into or onto an Enclosure or Worktable, be sure that it is stable and level. Always anchor the leveling feet or the frame to the floor.
- When servicing equipment in rack mount drawers:

- If you have multiple rack mount drawers, only unlock and extend the drawer you are servicing.
 - Extending multiple racks at once may cause the entire unit to fall over. Extend only one rack mount drawer at a time.
 - Extend rack mount drawers slowly. Sudden deployment of the rack could cause tipping.
 - Always load heavy items at the bottom of the rack mount drawer first, and add lighter equipment on higher levels. Putting heavy items high up is dangerous.
- There is a safety risk when equipment is mounted on a shelf installed more than 30 inches above the floor. Unsecured equipment may slide off of shelves and injure personnel. Be sure equipment on shelves over 30 inches from the ground is secured to the frame of your Enclosure, Work Table, or Shelving System.
- PQS products can be configured in many ways. The amount of force required to make the units unstable is different in each configuration. Read and fully understand all safety considerations in this entire manual before you assemble your configuration.
- There are task specific safety notes throughout this manual. Please read the entire manual and observe the warnings for each specific step.

Tools Needed

You may need some or all of these tools and possibly others depending on your particular assembly:

Socket Wrench	7/16", 9/16", 1/2" Heads
Power Drill	For fastening self tapping screws and drilling holes
Standard Drill Bits	For drilling holes when mounting accessories
Screwdriver Bit	#2 Phillips Head
Flat File	For taking down any sharp edges on sheet metal
Blue Painter's Tape	For marking mounting positions on shelving standards
Scissors	For cutting flexible grommet stripping to length
Marker	For marking any holes to be drilled when mounting accessories
Measuring Tape	For verifying shelf heights
Round File	For deburring any holes you've drilled
Level	For help adjusting leveling legs and shelves

How to use Self Tapping Screws

Many of the parts of the product assemblies are attached with Self Tapping Screws that must be installed into predrilled pilot holes. You'll need an electric screw gun or drill and a #2 Phillips Screw Driver to install these screws.

1-Observe the construction of the screws. Note that the point of the screw is shaped and operates like its own drill bit. Also note the length of the threaded shaft portion of the screw and that the head of the screw is a Type #2 Phillips.

2- Install the correctly sized Phillips screw driver bit into the chuck of the electric screw gun or drill. These screw driver bits are often magnetized to hold the head of the metal screw in place while driving it into the metal. Set the clutch of the drill to about half of its total range. If the clutch begins to slip before the screw is fully installed; increase the clutch setting slightly and try it again.

3- Start by placing a screw in the bit and then carefully align the point of the screw directly against one of the pre drilled pilot holes. Be sure to hold the drill straight and apply only enough pressure to guide the screw and keep it centered in the pilot hole.

4-Press the trigger of the drill to slowly begin the rotation of the screw. As the tip of the screw begins to drill into the surface of the metal, you may slightly increase the pressure against the screw. Keep even pressure on the screw as the screw point penetrates the surface of the metal and the threaded shaft of the screw is drawn into the newly made hole. Stop the drill when the head of the screw contacts the surface of the metal.

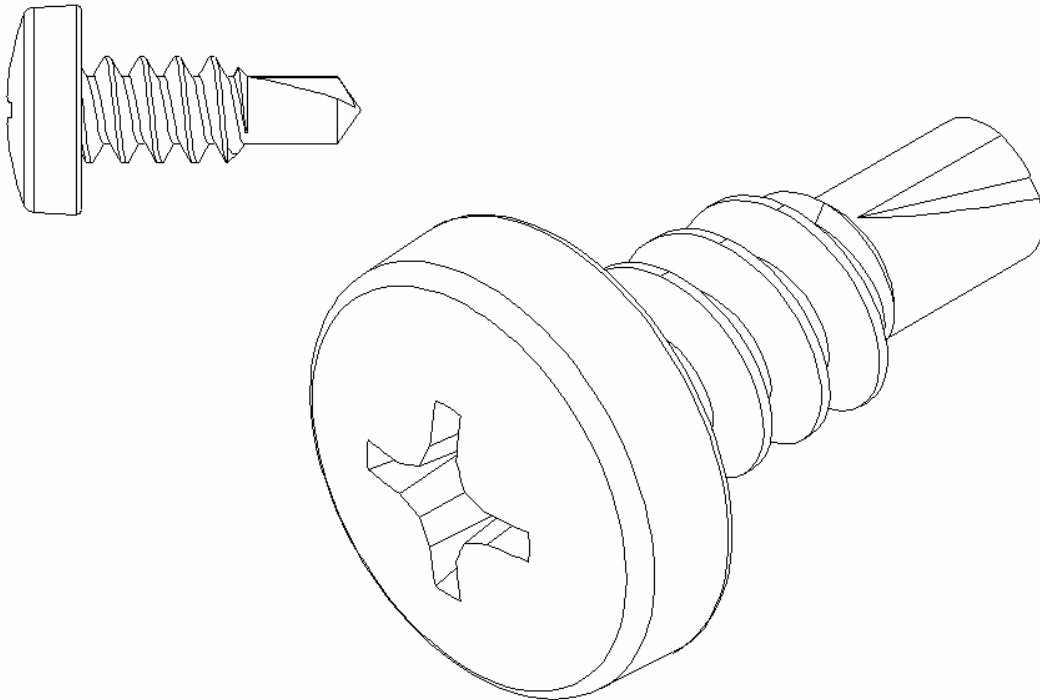

Basic Steps

Unpack the Shelving System

The Shelving System will arrive on a pallet or skid. It is recommended that the unpacking of the pallet or skid be done in close proximity to where the final installation will be. The Shelving System pieces will be strapped to the pallet or skid with plastic shipping wrap. This instruction manual should be attached to the top of the shipment.

1. Read this manual in its entirety paying particular attention to safety warnings throughout.
2. Carefully remove the shipping wrap with a knife cutter.
3. Remove the components from around the outside of the shipment and lay them aside.

Inspect the Shelving System, Accessories, and Hardware Kits

With all of the components laid out, take some time to identify all of the pieces you ordered. It is recommended that you become familiar with all of the parts before you begin the installation.

1. Refer to the product descriptions near the end of this manual for a basic list of components that are included in your assembly. Verify that all the components are present.
2. Inspect all of the pieces to ensure there aren't any defects or damage that occurred during shipping.
3. Identify the hardware kits. These bags contain the fasteners that you will need for the final assembly of your product. They will be marked with their hardware kit number and contents.

Installing Lower Shelf on the wall with the Wall Mount Brackets

***Note: The 45" Wide configuration is pictured in this section, but the installation of the 72" Wide model is very similar. The shelf of the 72" version is proportionally longer, and you will use the outside set of mounting holes rather than the inside set (See picture below).**

1. Lay the brackets down with the side that will mount to the wall laying flat on the floor.
2. Attach the simple shelf to one of the brackets by loosely threading the 4 ¼" screws from Hardware Kit # 75704 through the outside of the bracket where there are 4 holes in a line and into the threaded holes on the shelf. Make sure the solid face of the shelf is facing the top of the bracket where you will be mounting the Enclosure or Work Surface.

Note that the brackets are both the same and can be attached on either the left or the right depending on which way they are turned.

3. Attach the other bracket in the same way.
4. Once all of the screws are partially threaded and the shelf is in the correct orientation, tighten all of the screws down.

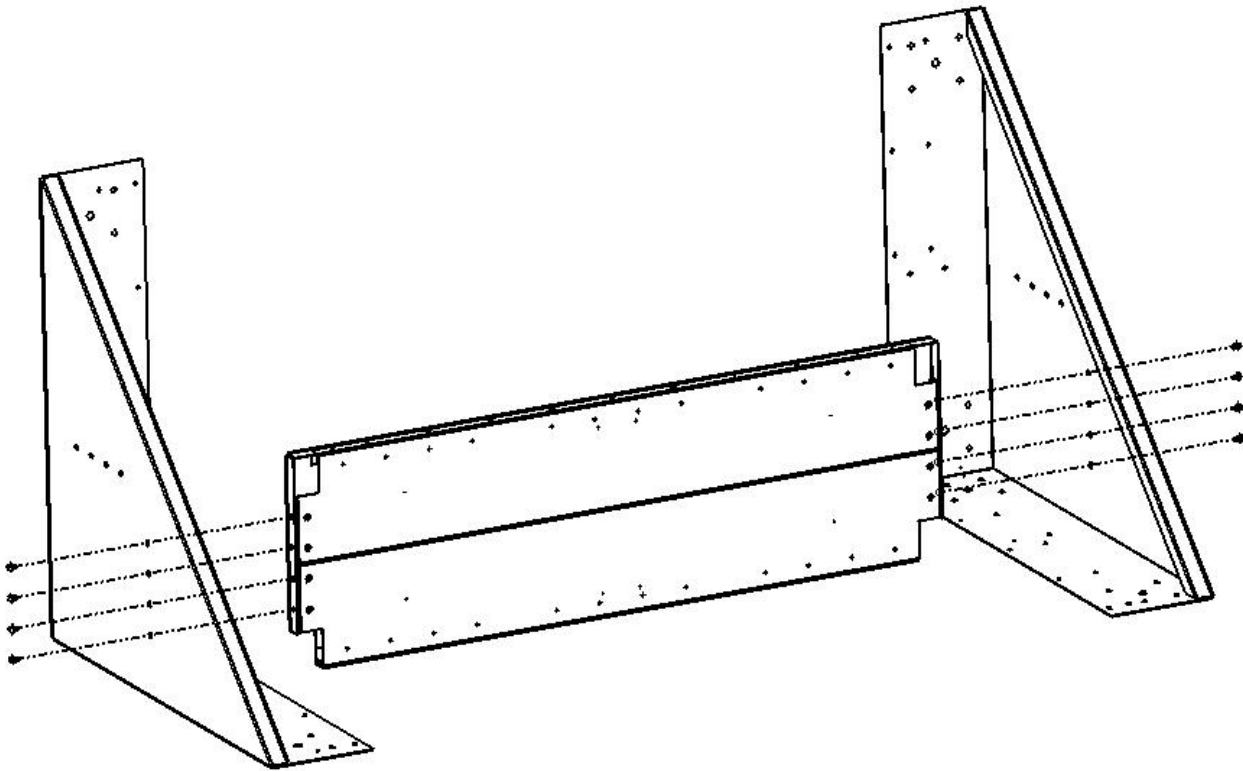

Once the shelf is securely attached, it will help 'square up' the brackets for wall attachment.

Attaching the wall mount brackets to the wall



WARNING The brackets must be fastened to a solid wall or studs, backing, or other structure within a hollow wall.

Each bracket must be fastened using the 5 vertical hole pattern shown in this section.

1. Find the studs or other structure that you will be mounting brackets to and mark the height on the wall.
2. Examine the wall mount brackets and note the series of mounting holes along the back sections where the brackets will lie flat against the wall.
3. Acquire a 10 count of the type of 1/4" diameter bolt that is appropriate for the surface you are mounting into. It is recommended that you also acquire accompanying fender washers.

4. If you are installing the brackets on a hollow wall, note that the series of mounting holes along the back sections where the brackets lie against the wall are spaced to align with studs that are spaced 16" on center.

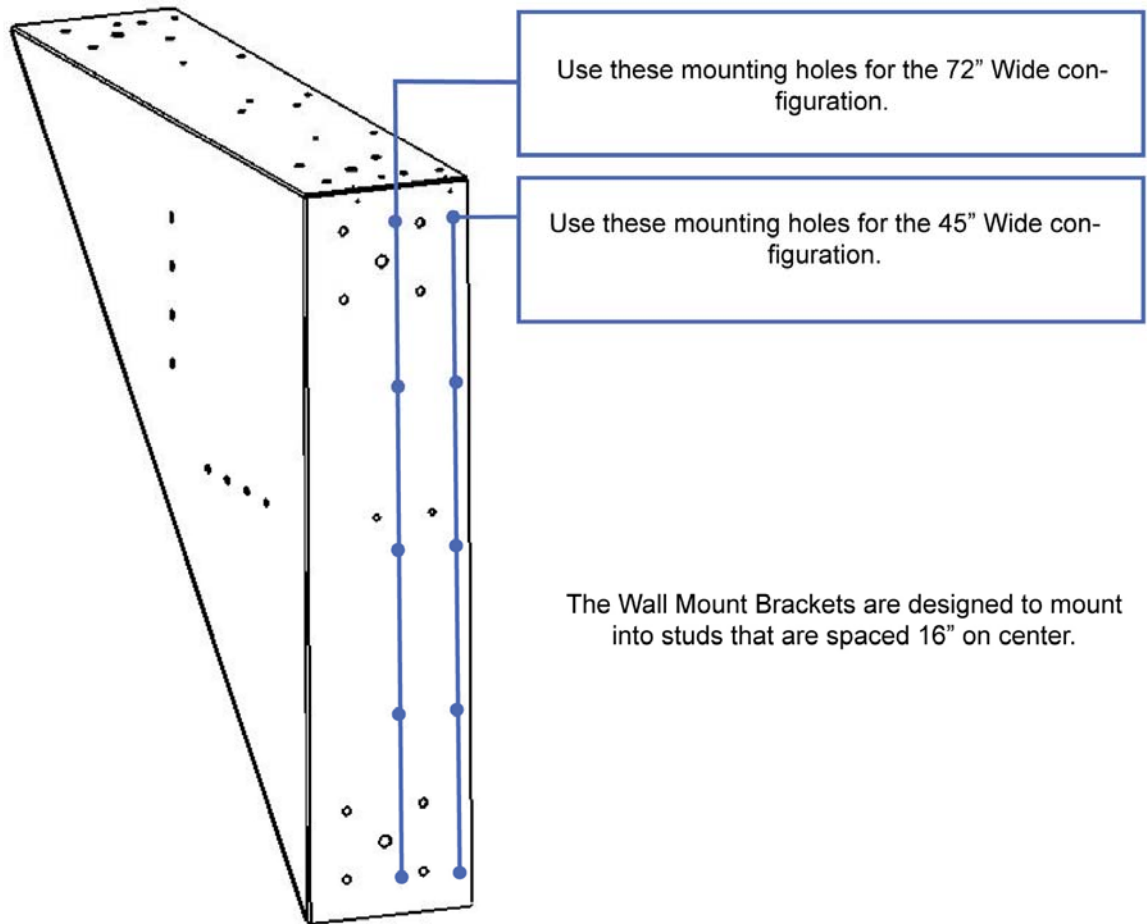

Tip Mark the height on the wall at which you want the Enclosure or Work Surface to sit at.

To install the Enclosure so that it is at the height of a standard desk, attach the wall mount brackets so that the top edges are at 30" above the floor.

5. Have an assistant help you hold the bracket and shelf assembly up to the wall. Place a level on the shelf while you are mounting the assembly so that it will be level. The brackets must be exactly level or the Enclosure cannot be attached.

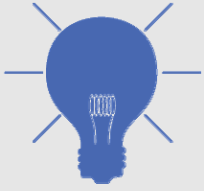

Tip If you have the materials, it is advised that you make a jig that you can place under the shelf so that it will sit level at the height you want the Brackets mounted at. A sturdy box of the appropriate size or some lengths of wood can work.

6. Use the 10 of the $\frac{1}{4}$ " bolts with washers to attach the brackets into the wall.

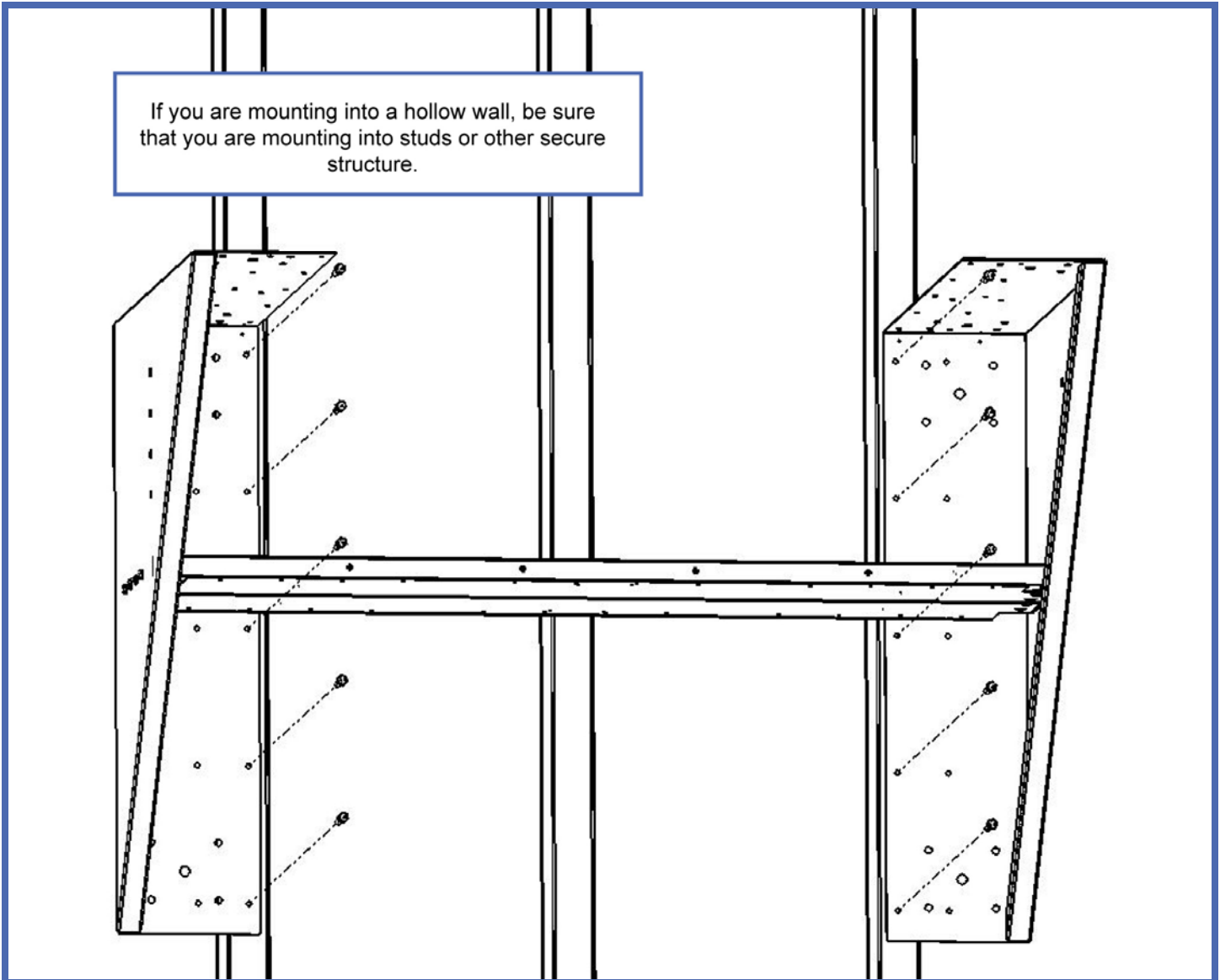

Installing the Work Table on the Wall Mount Brackets



WARNING Have as many assistants as necessary help you to comfortably and safely lift the Work Table top.

Place the Work Table Top on the top of the Wall Mount Brackets and align the 24 threaded holes in the insert plates of the bottom sides of the Work Table top with the holes on top of the Wall Mount Brackets.

Loosely install the 24 5/16" bolts with washers up through the wall mount brackets and into the threaded inserts. Once all of the bolts are installed, verify that the bottom edges of the sides of the Enclosure are properly aligned with the top of the Wall Mount Brackets and then tighten all of the bolts securely.



Tip If you will be installing Vertical Shelving Standards above your Work Table, leave out the 6 rear bolts that correspond to the holes in the top of the Work Table Surface.

Secure your Work Table using 24 of the 5/16" bolts and accompanying washers

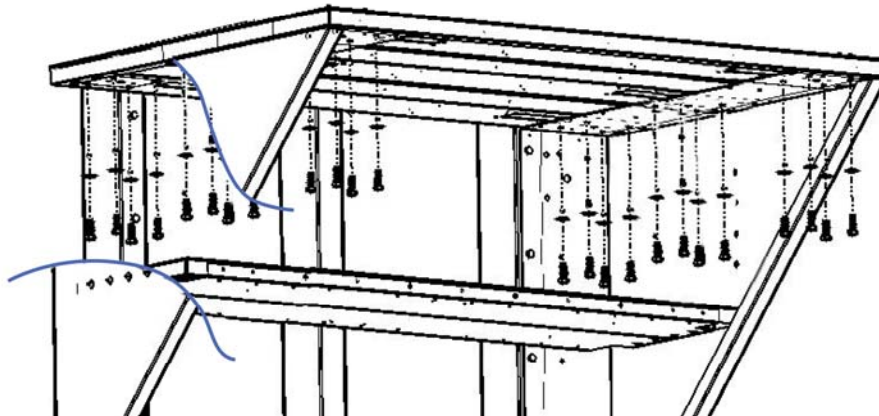

Installing the Vertical Shelf Standards above a Work Table

If you ordered a Work Table configuration with Upper Shelves or Upper Cabinets, your Work Table top will come pre-drilled from the factory ready to accept the 6 5/16" bolts that will secure the Vertical Shelf Standards. If you are retrofitting a Work Table with Vertical Shelf Standards, 6 holes will need to be drilled. Refer to the manual that came with your accessory order for more retrofit information.

1. Examine the two Vertical Shelf Standards and note that there is one left and one right standard and each has a base plate attached to one end that has three mounting holes. These mounting holes will align with the three holes in each of the back corners of the Work Table
2. Look under the Work Table top and examine the bolt patterns that secure the Table Top to the Side Supports. The rear most of these patterns will need three of the bolts removed. The bolts that need to be removed are those that correspond with the holes in the Table Top. Use a 1/2" socket wrench to remove them.
3. Locate the 6 - 5/16 bolts, nuts, and washers included in the Hardware Kit # 75717.
4. Align the three holes in the base plates of the left and right Vertical Shelf Standards with the three holes in left and right rear corners of the Work Table top.
5. Using the ratchet and a 1/2" socket wrench, loosely install the 5/16" bolts with washers through the base plates of the shelf standards and into each of the 6 threaded holes.
6. Thread on the 6 nuts on the underside of the assembly. Check that the base plates are correctly aligned with the corners of the Work Table top panel and then tighten the nuts securely.

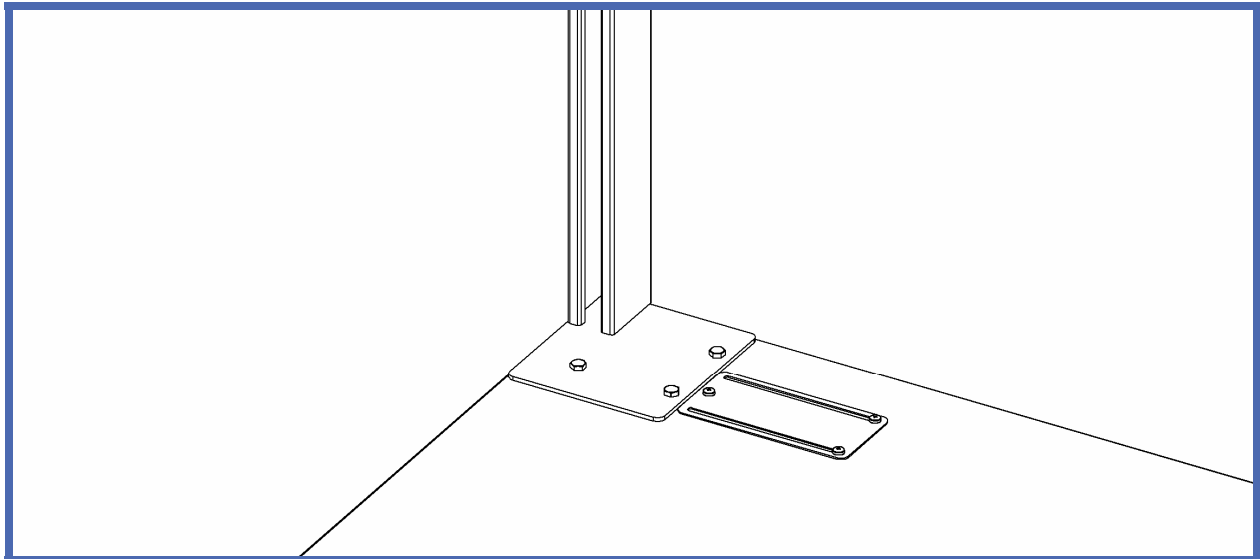

Installing shelves on Vertical Shelf Standards



Tip Use a small piece of paper tape to mark the desired shelf position on the sides of the Vertical Shelf Standards.

1. Prepare two Shelf Brackets by inserting two 3/8" bolts with washers through the Shelf brackets and thread a Channel Strut Nut a few turns onto the ends of each of the bolts.



Tip Note that the Channel Strut Nuts have two grooves across the face and they are wider than the opening along the front of the Vertical Shelf Standards. The grooves in the channel strut nuts must be oriented so that they will contact the inside rail like edges of the Vertical Shelf Standard. See picture below for visual reference.

2. Hold each Shelf Bracket at an angle to the opening of the Vertical Shelf Standard and guide the Channel Strut Nuts attached to the bolts into the Vertical Shelf Standard.

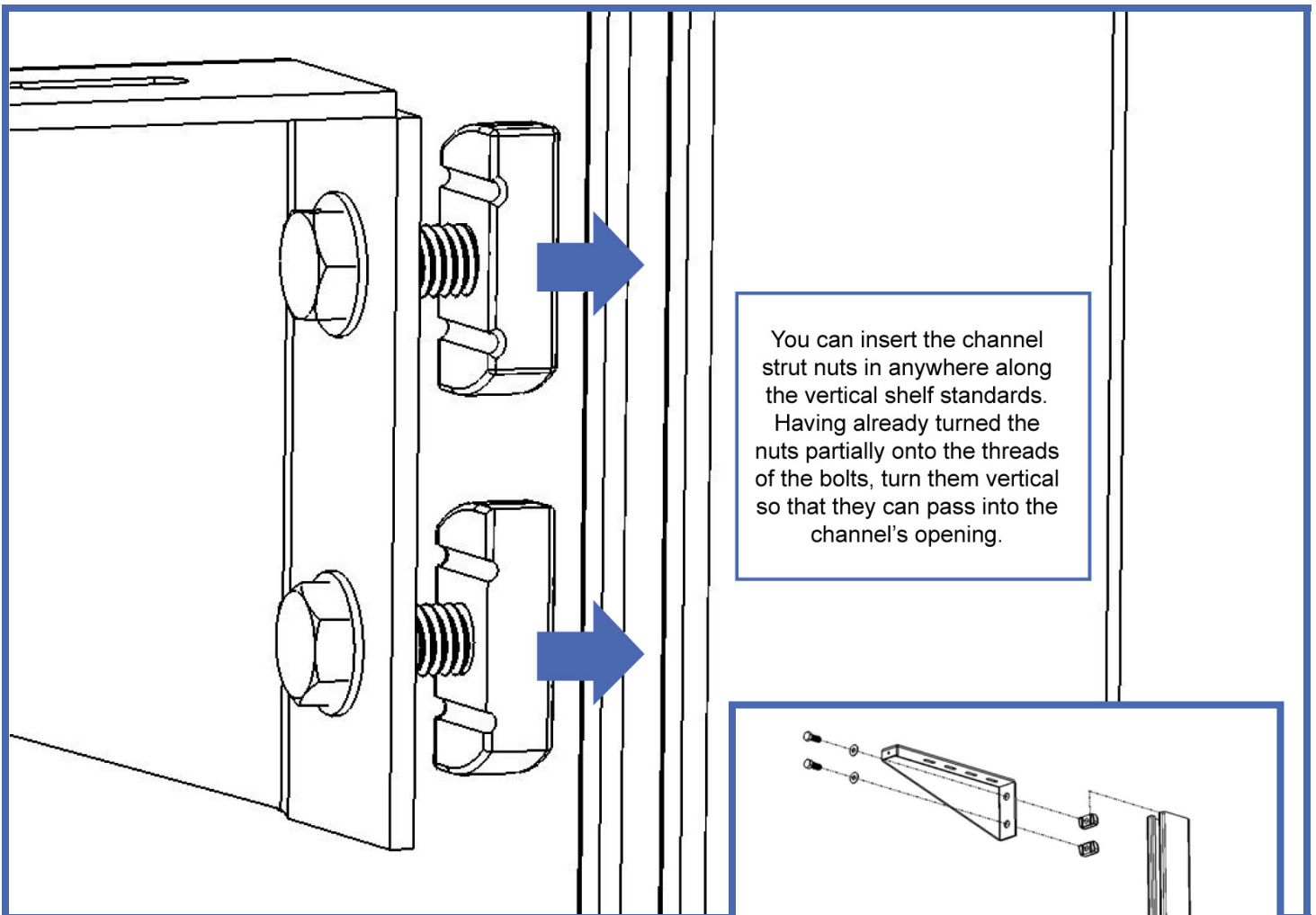

3. Verify that the Channel strut Nuts are oriented so that the grooves are oriented vertically inline with the inner rails of the Vertical Shelf Standard and that they “bridge” across the opening of the Vertical Shelf Standard.

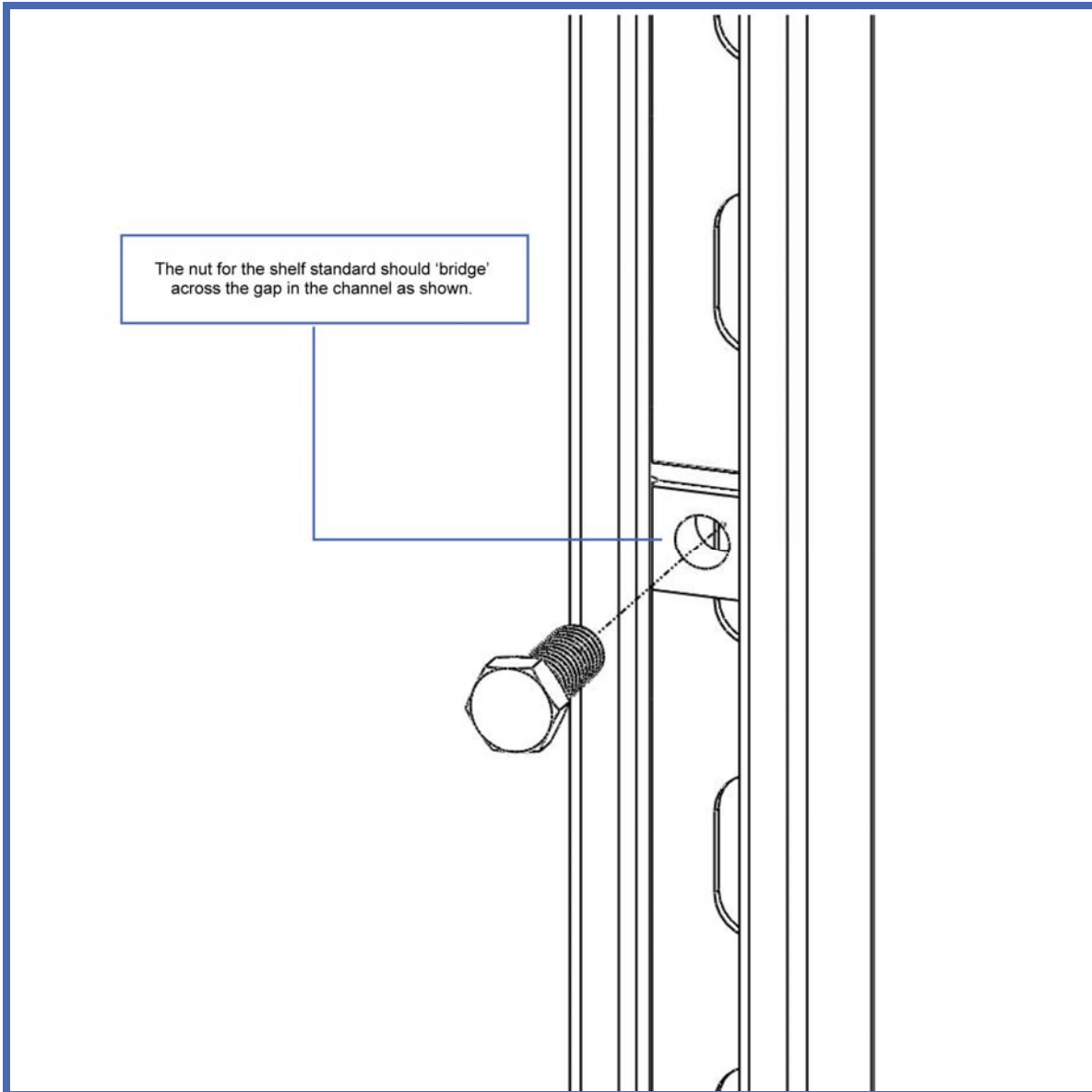

4. Pull the bracket out from the Vertical Shelf Standard so that the Channel strut Nuts contact the inside of the Vertical Shelf Standard and carefully tighten the bolts to pull the Shelf Bracket loosely against the Vertical Shelf Standard.
5. Raise each shelf bracket assembly to the desired height.
6. Measure the heights of both the right and left shelf bracket, verify that they are level then tighten the shelf bracket retaining bolts to secure the shelf brackets to the Vertical Shelf Standards.

If your Shelving System has an Upper Cabinet: Upper Cabinet Overview

The Upper Cabinet Kits- 45" wide cabinets include two Upper Cabinet two door assemblies and 72" wide cabinets include three door assemblies and two door dividers. All cabinets include two stainless steel sides, one galvanized Upper Cabinet back panel, two 14" shelves with stainless steel tops that will create the top and bottom of the cabinet, four galvanized shelf brackets, and a hardware kit. The cabinet doors feature heavy duty magnetic catches with have integral door handles that can be secured with a padlock either keyed or combination type (not included). On 72" wide assemblies a padlock with a 3.5" Long shackle is needed to reach between doors.

Interior dimensions for cabinets are approximately 18"H X 44"W X 14" D 45" wide cabinets and 18"H X 71"W X 14" D for 72" wide cabinets.

Note that the top and bottom sections of the Upper Cabinet assembly are made of standard Half Depth Shelves with Stainless Steel tops.

In the standard configuration the bottom Shelf is turned upside down in order to place the Stainless Steel side on the outside of the bottom of the cabinet and place the lower Shelf brackets on the inside of the cabinet.

Pre assembly for the Upper Cabinet

Assemble two shelves

1. Lay the shelf assemblies solid side down.
2. Place the shelf brackets on the shelf so that the four slots line up with the four threaded holes on the bottom of the shelf.
3. Align the four slots in the tops of the shelf brackets with the four threaded holes in the bottom of the shelf.

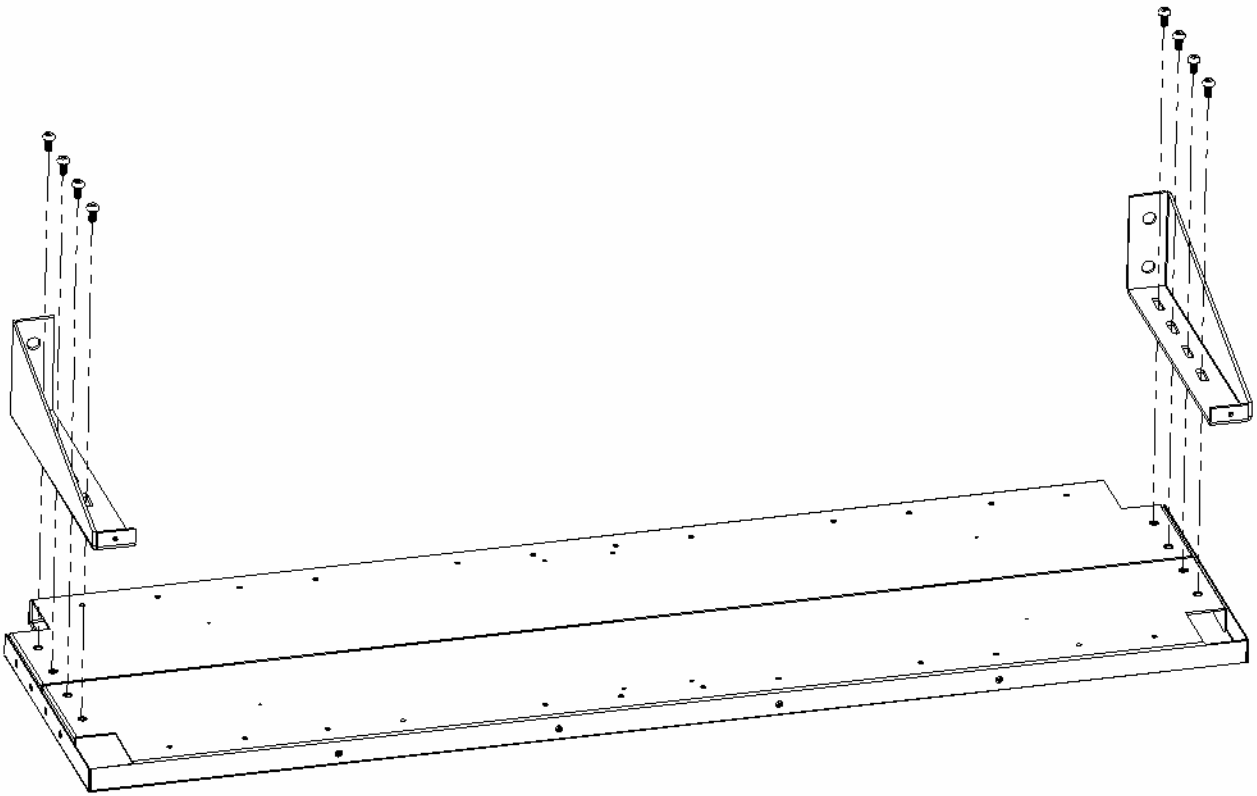

4. Insert four 1/4" -20 screws with washer through the slots in the shelf brackets and loosely thread them into the threaded holes on the bottom of the shelf. Verify that the front edge of the bracket is flush with the shelf, before tightening the eight screws to secure the shelf to the shelf brackets.

Install the cabinet top

1. Determine where you want your cabinet to sit on the vertical shelf standards.



Tip Use a small piece of paper tape to mark the desired position for the cabinet's top on the sides of the Vertical Shelf Standard. Make note that the cabinets are 18" high, so be sure to allow enough room below your mark to allow the rest of the cabinet to fit.

This step will be easier with an assistant to hold the shelf up while it is being fastened to the shelf standards.

2. Insert the 3/8" bolts with washers from Hardware Kit # 75710 through the holes on the shelf brackets.
3. Loosely thread channel strut nuts (See pictures below for visual reference) from the same kit onto each bolt.
4. Have an assistant help you lift the shelf to the desired location on the vertical shelf standards.

5. With the channel strut nuts turned vertically, insert them into the vertical shelf standards.

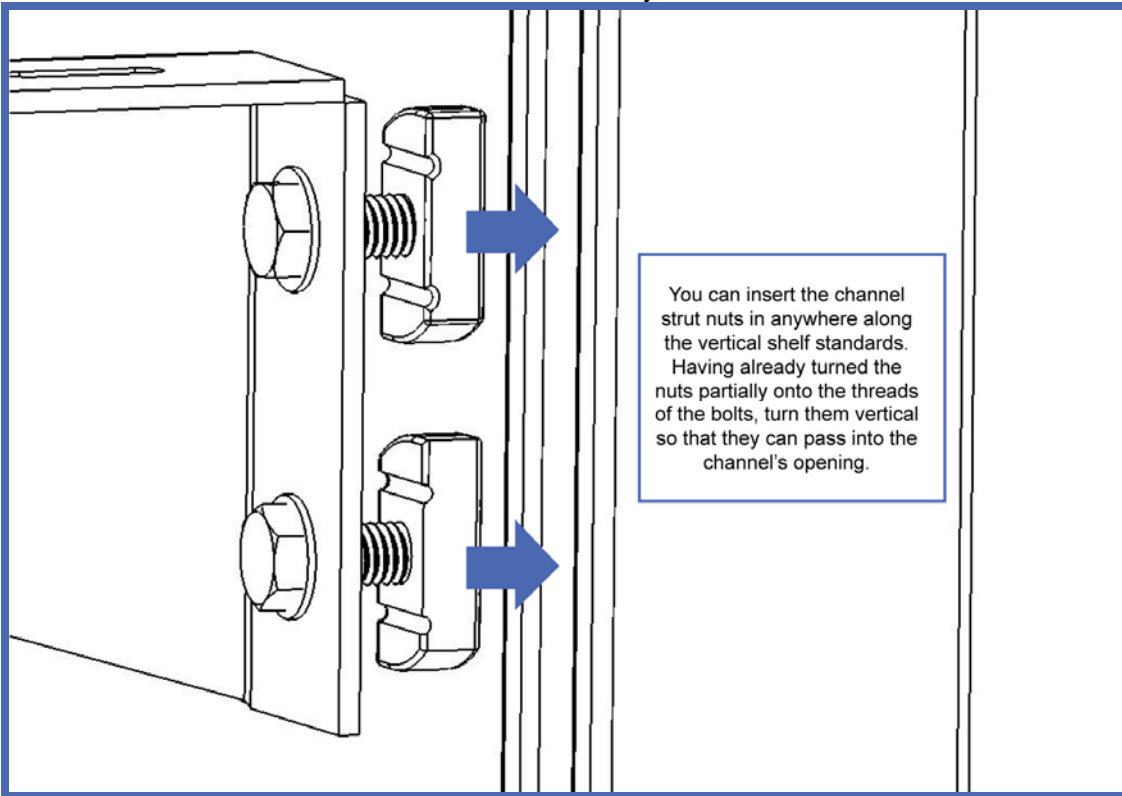

*Shelf omitted for clarity

6. With the nuts inside the channel, use a screwdriver or other rigid probe to turn them horizontal.

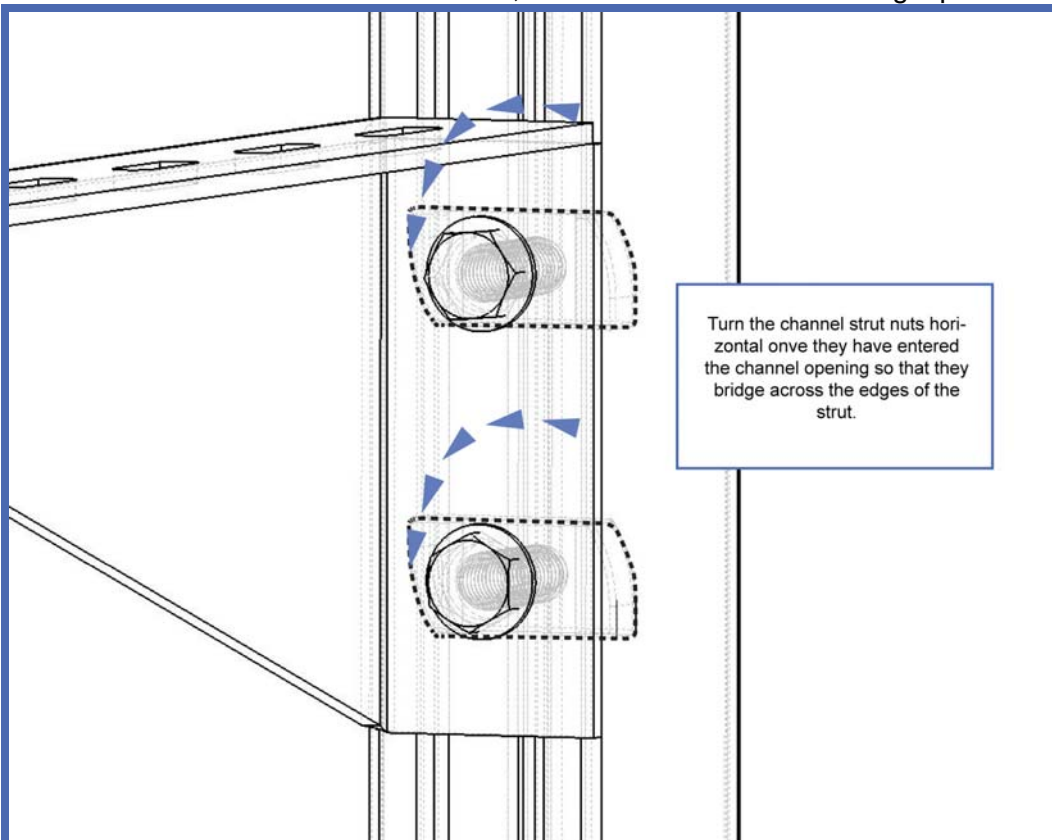

*Shelf omitted for clarity

7. Tighten the bolts down until they hold up the shelf on their own.

8. Use a level to make sure the shelf is horizontal.
9. Tighten the bolts down fully.

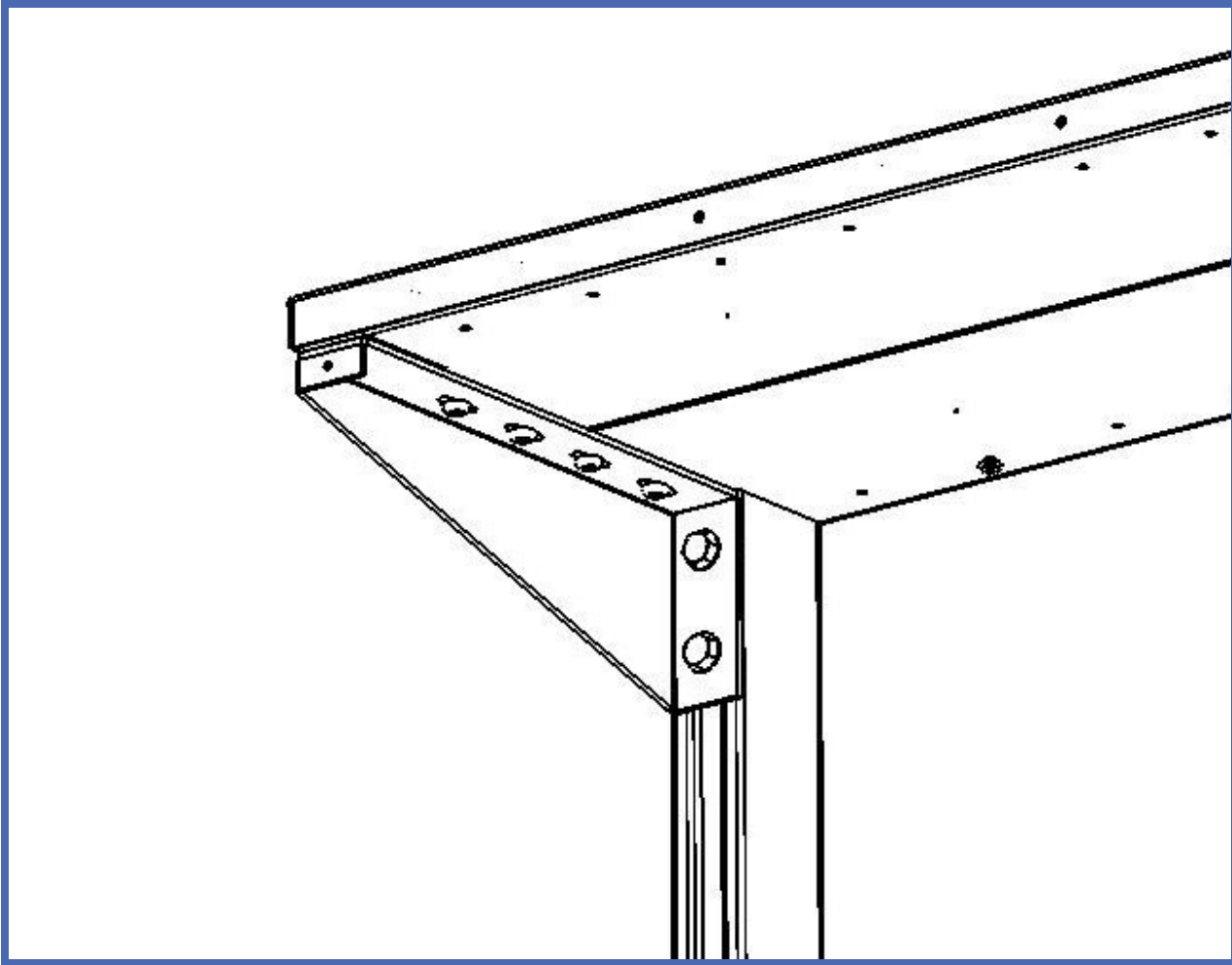

Installing the Upper Cabinet sides and back section

1. Lift one of the Upper Cabinet Side sections and align the bent edge towards the front edge of the shelf.
2. Align the four 1/4" holes along the lower edges of the side section with the four threaded holes in one of the shelf.
3. Insert 4 -1/4"-20 SS screws from Hardware Kit # 75710 through the four holes in the side section and thread them loosely the four threaded holes in the ends of the shelf.
4. Now install another side section on the other end of the top shelf in the same way. Do not tighten the screws until all of them started in the threaded holes.

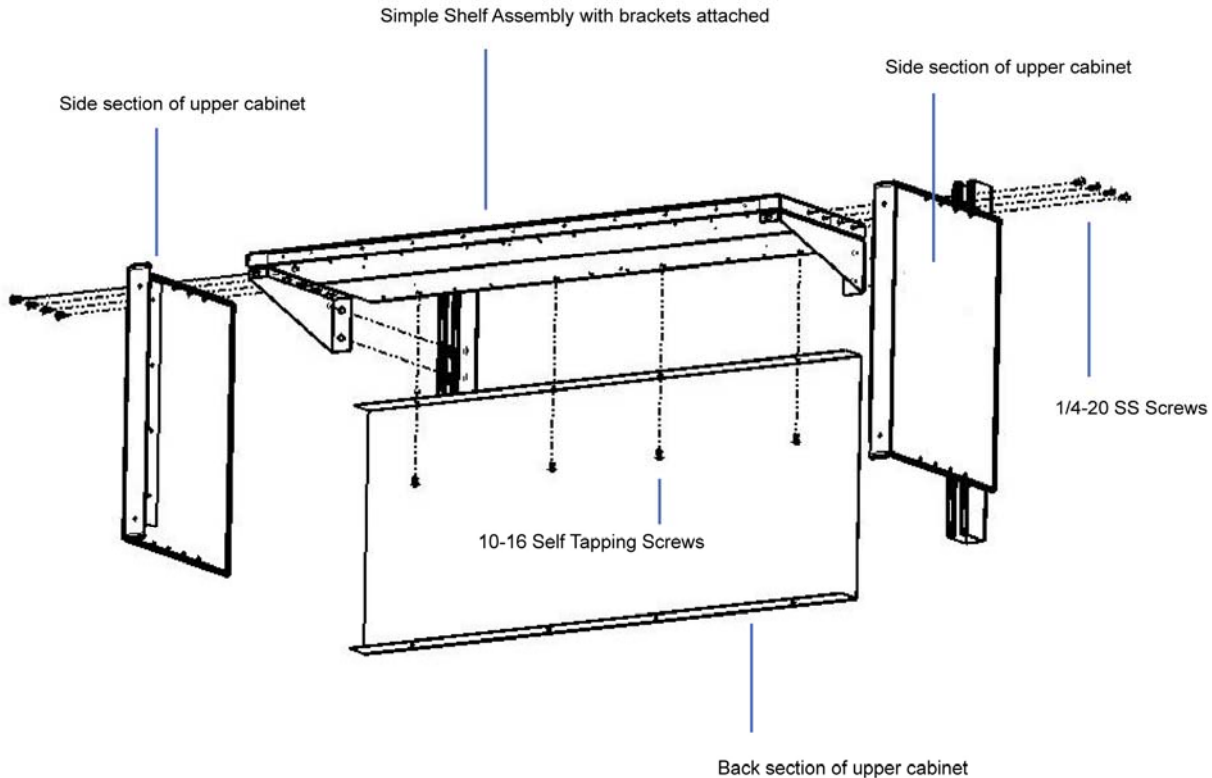

*The 45" W configuration is shown. The shelves which compose the top and bottom of the 72" cabinets are proportionally longer than pictured.

5. Have an assistant help you lift the Upper Cabinet back section up so that the four holes in the lip of it line up with the pilot holes in the very back of the upper shelf.

6. Attach the Upper Cabinet Back Section with 10-16 self tapping screws from the same Hardware Kit to the back of the top shelf.

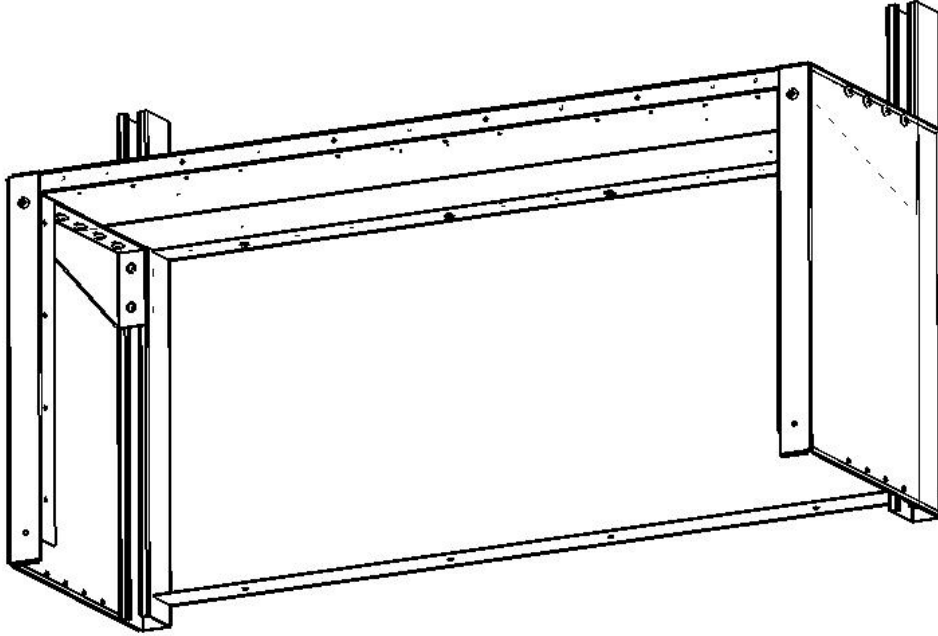

Installing the bottom of the Upper Cabinet

1. Lift the other shelf and turn it so that the Stainless Steel top is facing down and the split galvanized side is facing up (you are installing another shelf upside down to be the bottom of the cabinet).
2. Insert two more 3/8" bolts with washers from your Hardware Kit and loosely thread Channel strut nuts onto the end.
3. Make sure to turn rear edge with the cut out corners toward the back of the cabinet assembly, and carefully slide the shelf between the two side sections and up against the inside of the back section.
4. Turn the channel strut nuts horizontal in the same manner when the upper section was installed.



Tip The process of lifting, aligning, and attaching the pieces onto the vertical shelf standards will be made much easier by having one or more people assist you.

5. Align the holes along the bottoms of the side sections with the threaded holes in the ends of the shelf and loosely thread 4 -1/4"-20 SS screws through the holes in each of the side sections and into the threaded holes on the ends of the shelf.



Tip Do not tighten the screws until all of them are started in the threaded holes.

- Now attach the Upper Cabinet Back Section with 10-16 self tapping screws to the back of the bottom Shelf.

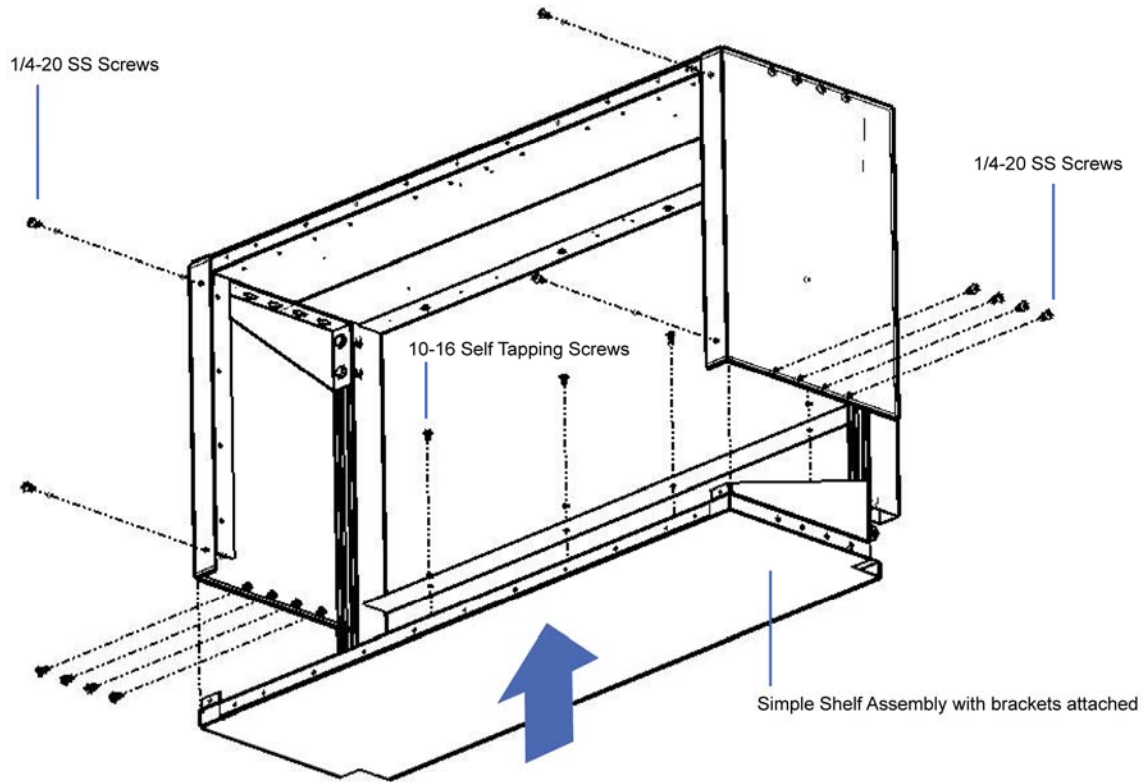

- Install the last four $\frac{1}{4}$ x 20 screws in the front corners of the sides. These should thread into the front of the brackets.
- Verify that the shelf is aligned correctly and then tighten all of the screws and bolts.

Installing the 72" W Upper Cabinet Doors Assemblies

If you are assembling a 72" wide cabinet, install the two door dividers first and attach them to the upper and lower shelf assemblies with six shelf tapping screws.

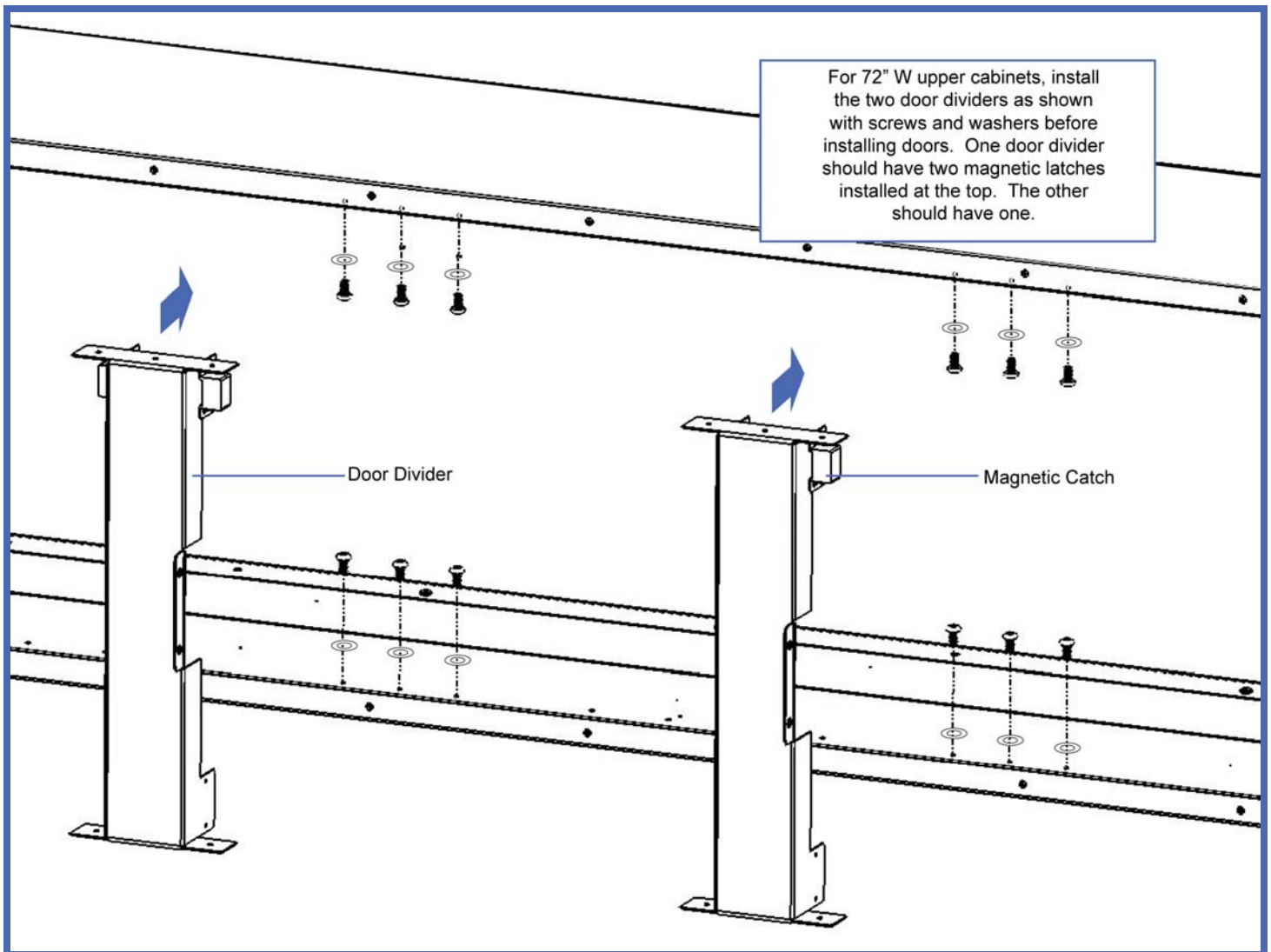

Beside the difference of having door dividers, the door installation on the 72" W and the 45" W upper cabinet assemblies are very similar. Note that the middle door on a 72" W upper cabinet will have to be attached to the door divider instead of the side of the cabinet. Please see the diagrams below (which show the 45" W assembly) for reference on how to attach the doors.

If two door cabinets are meeting, they get one double sided magnetic catch installed in the middle, and three door configurations have one single sided magnetic catch installed for each door.

Note that if you want to lock the doors on a 72" wide upper cabinet, you will need a padlock that can span the 3.5" gap between the doors.

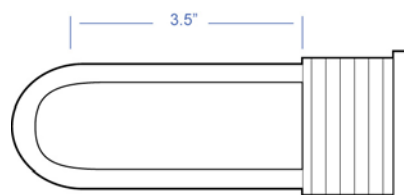

Installing the 45" W Upper Cabinet Doors Assemblies

1. For the 45" W configuration: Install the magnetic catches below the middle of the front of the top shelf with the two 6-32 x 1"L screws from Hardware Kit # 75710. See below for visual reference.
2. Hold one of the Upper Cabinet Door assemblies so that the holes in the hinge align with the holes along the inside edges of either the right or left Upper Cabinet side sections.
3. Secure the top most fastening point with a 10-32 machine screw that passes through the hinge, the cabinet side, and loosely thread a lock nut from the same Hardware Kit onto the end so that it is held in place.
4. Repeat this process with the remaining holes.
5. Carefully close the door assembly and verify that it aligns correctly with the front edges of the top and bottom shelves. Carefully open the door and while supporting the free edge of the door, tighten each screw along the hinge to secure the door to the Cabinet side sections or the door divider.
6. Repeat the above process with the remaining doors. If there is a slight misalignment of either of the doors, carefully loosen all of the screws holding the door until the door can be moved slightly and raise or lower the door while supporting the free edge and then retighten all of the screws along the hinge and recheck the alignment of the door.

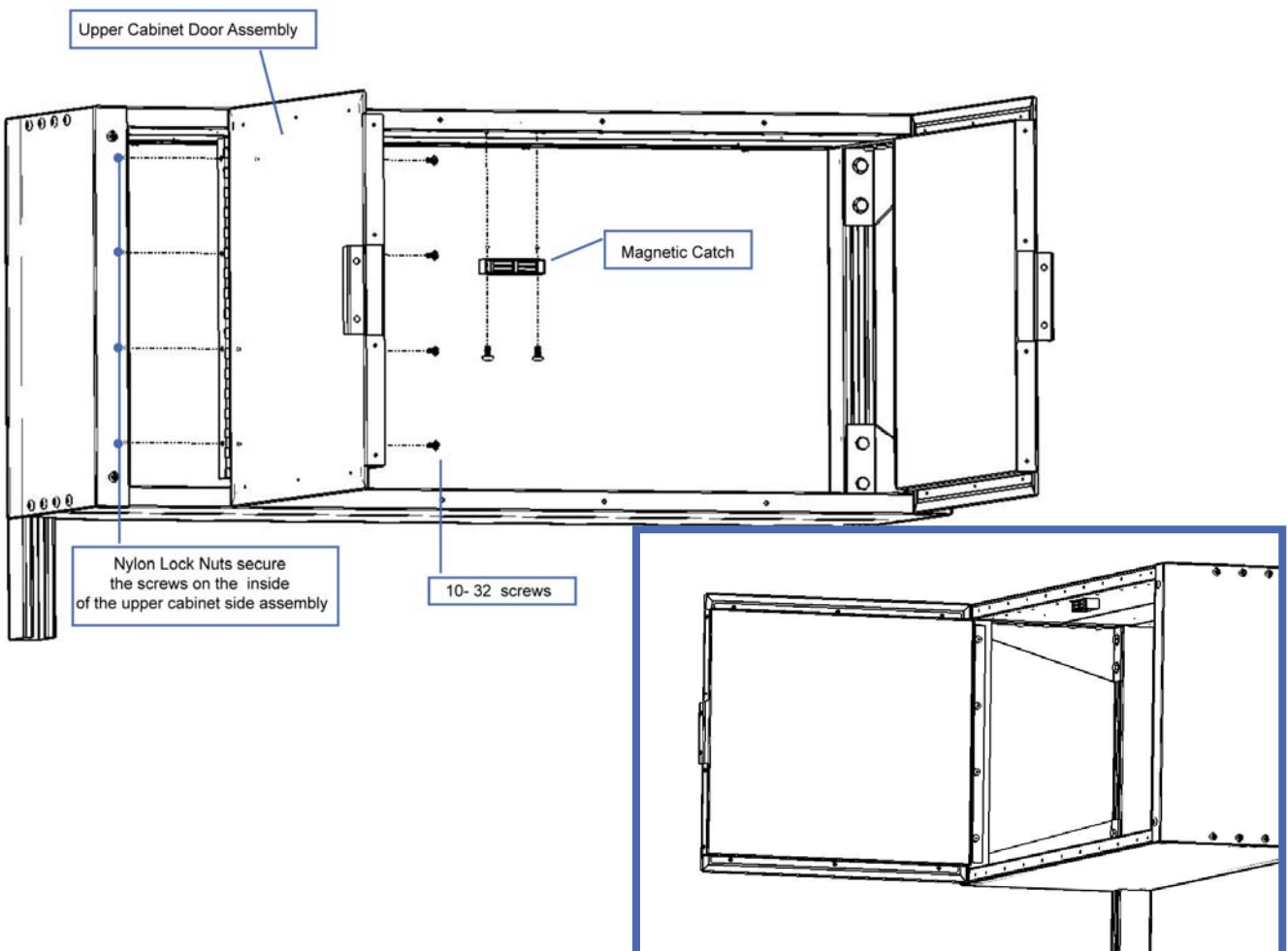

Optional Steps

Adjusting the Height of a Shelf



WARNING Remove any items on the shelf.



Tip Use a small piece of paper tape to mark the desired new shelf position on the sides of the Vertical Shelf Standards.

1. Support the shelf and carefully loosen the four shelf bracket retaining bolts just enough so that the shelf can be moved vertically along the channels in the Vertical Shelf Standards.
2. While still supporting the entire shelf, carefully raise or lower the shelf with the shelf brackets along the channel to adjust the height of the shelf to the desired new position.
3. Check that the shelf is level and then tighten the four shelf bracket retaining bolts to secure the shelf to the Vertical Shelf Standards.

Installing cabling through cable path openings on a Work Table

There are six Cable Path Openings on the 45" wide Work Tables with one on each of the right and left sides of the top near the rear, and two near the top and bottom of each of the Side Supports. The 72" wide Work Tables have an additional cable path opening in the center of the table top. There are additional cable passage slots through the rear corners of the rear Half Depth Lower Shelf. If your Work Table has a Full Depth Lower Shelf, there are also additional cable passage slots through sides of the middle of the Shelf as well. The cable passage slots in the shelves do not have covers.

v

1. To open any of the cable passage slots; remove the single screw at the end of the cover.
2. Slightly loosen the two screws on the sides of the cover so that the cover can be slid open as needed.

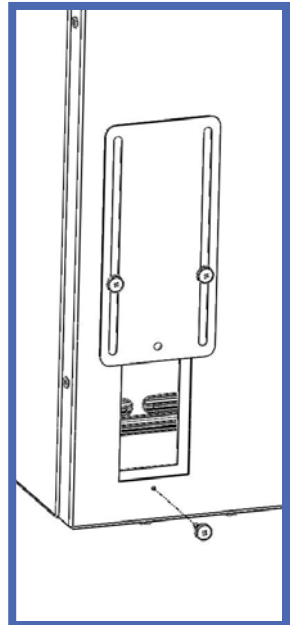
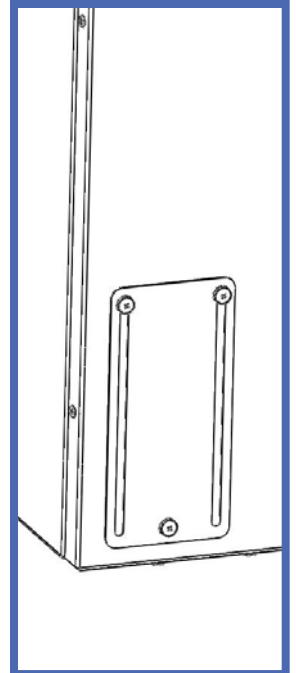

Tip After installing the associated cabling, slide the cable path cover down to reduce the open size of the cable passage slot to a minimum area. Be sure to leave enough room so that the flexible grommet stripping can be installed on the edges around the cables. See the next section for detailed instructions on flexible grommet stripping.

3. Once the opening is the desired size, retighten the two screws on the sides of the cover.

Installing flexible grommet material around cable path openings



WARNING: The edges of the cable path opening may be sharp. Use caution when installing the flexible grommet material.

The flexible grommet material is included to protect against possible wear on wiring resulting from contact with the cable path openings. It is necessary to install this edging on every sheet metal opening that wiring passes through to protect your equipment and to prevent wiring from becoming damaged.

***Note:** This procedure assumes that you have already adjusted your cable path opening to the desired width. If you have not done this, please refer to the section entitled "Installing low voltage cabling."

1. Find the flexible grommet edging material from your hardware kit #75702.
2. Holding one edge of the flexible grommet edging start pressing it onto one of the four corners of the cable path opening.
3. Continue pressing the flexible grommet onto the edge of the cable path opening until it has completely covered all four sides.
4. Use shears to snip off any excess edging.

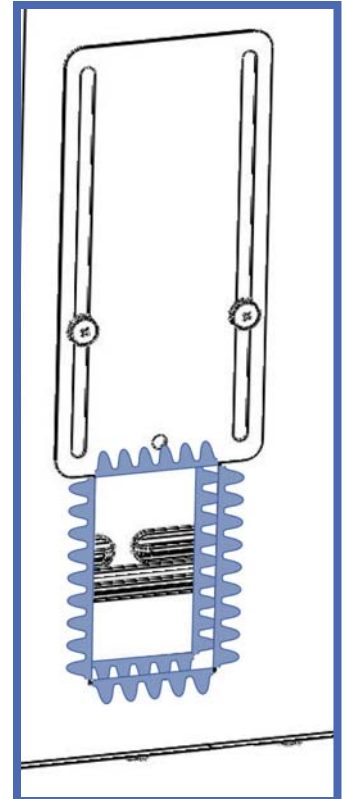

Product Short Descriptions

For complete descriptions of all items included in your assembly; please refer to the sections entitled “Standard Features” and “Included Options” on the individual product information sheets.

All product information sheets are available in PDF format on our website from the tool bar on the individual product pages or from our Product Resources page.

Shelving System 45W with a Work Table a Lower Shelf, a Upper Shelf and an Upper Cabinet PN 81360

Attaches to any wall and includes a 45"W X 30"D Stainless steel table top assembly, two galvanized Wall Mounting Brackets, 2- Galvanized 64" Vertical Shelf Standards, 1- Stainless steel topped 45"W X 14"D shelf assembly, 1- 18"H X 45"W X 14"D Stainless steel Upper cabinet assembly with two doors, one 44"W X 14"D lower shelf assembly with a galvanized steel top and a hardware kit.



Shelving System 72W with a Work Table, a Lower Shelf, an Upper Shelf and an Upper Cabinet PN 81361

Attaches to any wall and includes a 72W X 30D Stainless steel table top assembly, two galvanized Wall Mounting Brackets, 2- Galvanized 64" Vertical Shelf standards, 1- Stainless steel topped 72W X 14D shelf assembly, 1- 18H X 72W X 14D Stainless steel Upper Cabinet Assembly with three doors, one 71W X 14D lower shelf assembly with a galvanized steel top and a hardware kit.



Product Specifications 45" W x 92"H x 30"D

General Measurements: 45" W x 92"H x 30"D

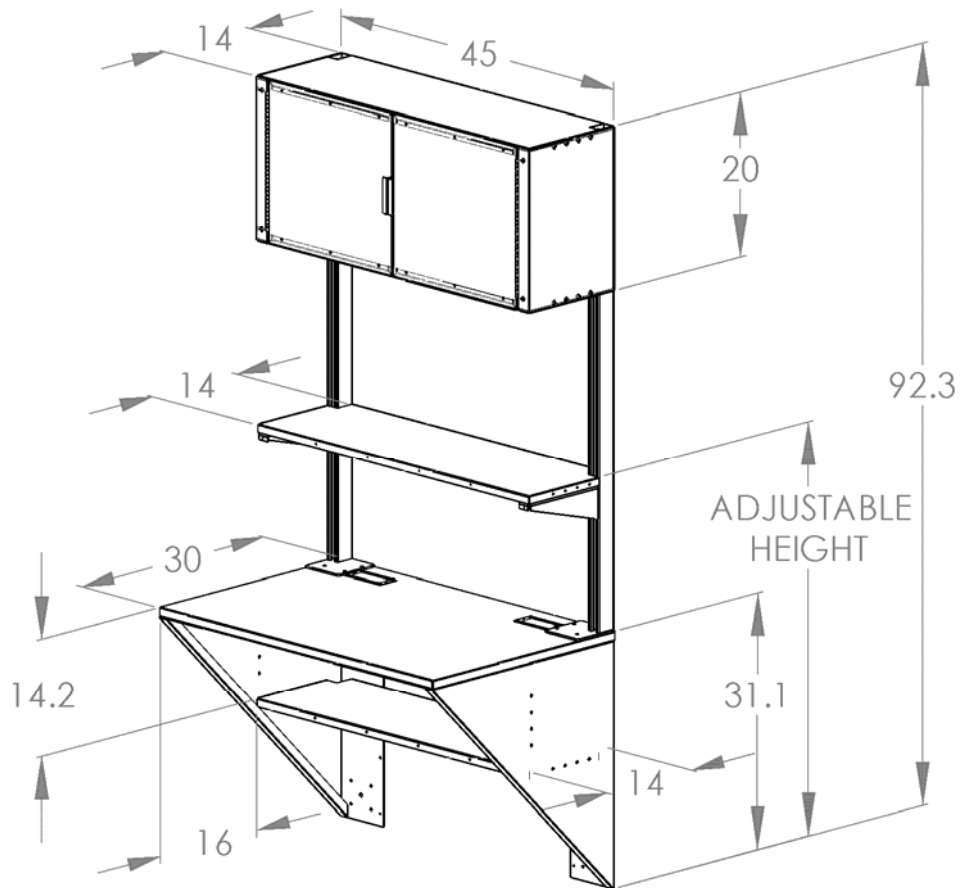

Weight:

45 W Shelving System w/ Work Table and Upper Cabinet Bare = approx 243 lbs. Note: This weight does not include any options or accessories.

Product Specifications 72" W x 92"H x 30"D

General Measurements: 72" W x 92"H x 30"D

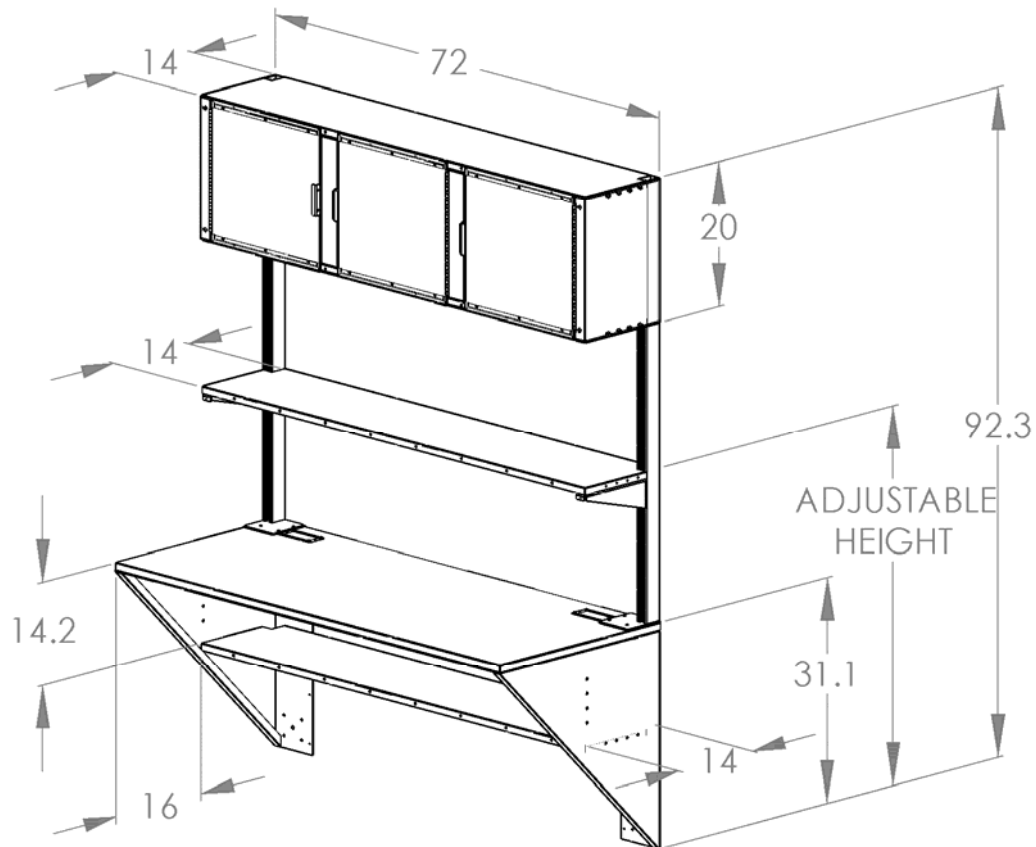

Weight:

72 W Shelving System w/ Work Table and Upper Cabinet Bare = approx 260 lbs. Note: This weight does not include any options or accessories.

Engineering Drawing Reference Notes:

To view and manipulate 3D models of any assembly; visit www.edrawingsviewer.com and download the free eDrawings viewer software, then open the eDrawing format files (.EASM) found in our Engineering Drawings folders.

For more product dimensional specifications; download the Engineering Drawings folder for files in DWG, PDF and EASM formats on our website from the tool bar on the individual product pages or from our Product Resources page.

Identifying External Components

45" Wall Mounted Work Table with Lower Shelf

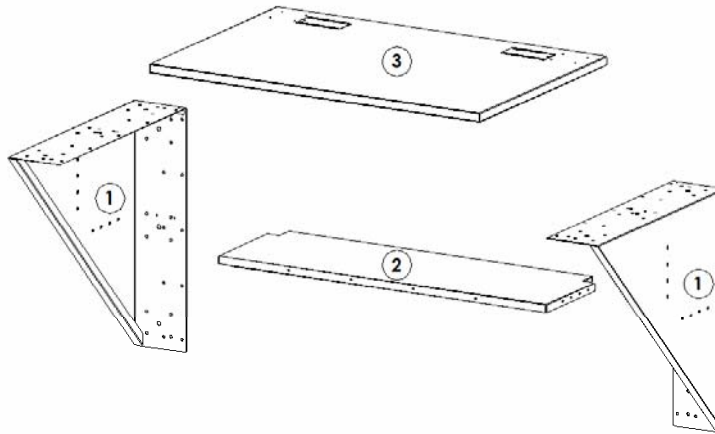

45" WALL MOUNTED WORK TABLE WITH LOWER SHELF			
BALLOON #	PART #	DESCRIPTION	QTY.
①	60135	WALL MOUNTED BRACKET	2
②	60039	SIMPLE SHELF SUB ASSEMBLY	1
③	60076	45" WORK TABLE SURFACE ASSEMBLY	1

45" Upper Cabinet Kit

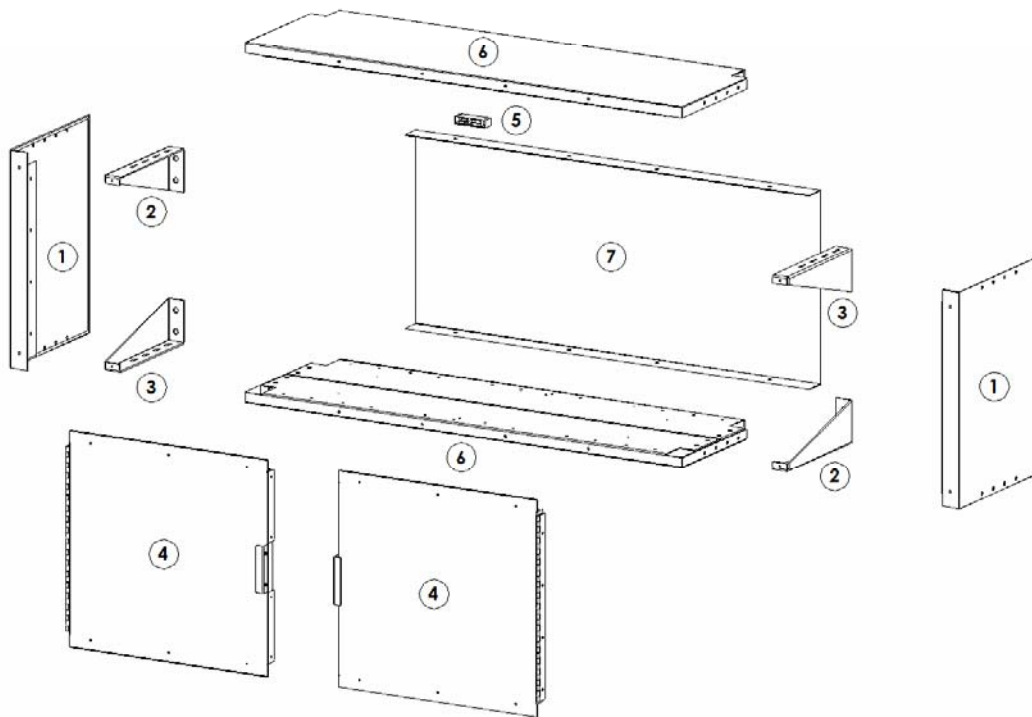

45"W UPPER CABINET KIT			
BALLOON #	PART #	DESCRIPTION	QTY.
①	50289	UPPER CABINET SIDES	2
②	50235	SIMPLE SHELF BRACKET (RIGHT)	2
③	50244	SIMPLE SHELF BRACKET (LEFT)	2
④	60047	UPPER CABINET DOOR ASSEMBLY	2
⑤	30021	LOWER CABINET MAGNET	1
⑥	60042	SIMPLE SHELF SUB ASSEMBLY	2
⑦	50290	UPPER CABINET REAR PANEL	1

61”w Shelving System with one 45” Upper Shelf

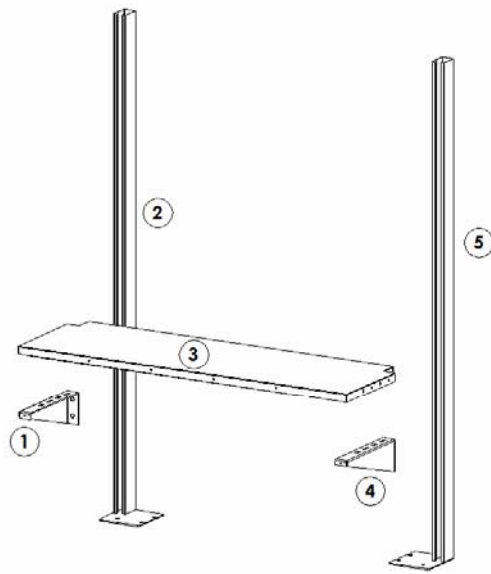

45" SHELVING SYSTEM W/1 UPPER SHELF			
BALLOON #	PART #	DESCRIPTION	QTY.
①	50235	SIMPLE SHELF BRACKET (LEFT)	1
②	60079	SHELF STANDARD ASSEMBLY (LEFT)	1
③	60042	SIMPLE SHELF SUB ASSEMBLY	1
④	50244	SIMPLE SHELF BRACKET (RIGHT)	1
⑤	60079	SHELF STANDARD ASSEMBLY (RIGHT)	1

Warranty Information

LIMITED WARRANTY

WHAT IS COVERED

Practical Quality Systems, Inc. (PQS) guarantees manufactured products and each part or component thereof against all defects in material and/or workmanship.

HOW LONG COVERAGE LASTS

The warranty extends for a period of one year from the date of installation or initial use, provided that this period shall not exceed 18 months from the original date of shipment from PQS.

WHAT IS NOT COVERED

This warranty does not extend to products that have been subjected to neglect, accident or improper use, nor to units that have been altered by non-PQS technicians.

WHAT PQS WILL DO

PQS agrees to remedy any manufacturing defect either through replacement or repair at no charge, provided that the defective unit is returned, transportation prepaid, to PQS.

HOW TO GET SERVICE

In order to be eligible for service under this warranty you must return the warranty registration card within 30 days of purchase.

- Authorization to return any product purchased from PQS for inspection must be obtained from an authorized Practical Quality Systems representative. All returns must be accompanied by a completed PQS return material authorization (RMA). An RMA will be generated by customer service department and must be pre-approved. We will inspect your product and contact you within 72 hours with the results.
- Any product that has been repaired or replaced shall be similarly warranted on its repair or replacement for the remaining product warranty period or 90 days from the date of repair or replacement, whichever expires last.

WARRANTY SCOPE

No warranties other than those set forth in this section are given or implied with respect to the products furnished. PQS shall, in no event, be liable for consequential damages, for loss, damage or expense directly or indirectly arising from the use of the products, for any inability to use materials or from any other cause.

YOUR RIGHTS UNDER STATE LAW

This warranty gives you specific legal rights, you may have other rights which vary state to state.

DAMAGE OR LOSS IN TRANSIT

Title to goods sold passes upon delivery to the carrier. Practical Quality Systems accepts no responsibility for damage or loss in transit. Practical Quality Systems will use commercially reasonable efforts to assist the Buyer in initiating action against the carrier for such losses. The Buyer must notify Practical Quality Systems in writing and the carrier as soon as the loss or damage is known and in any event, no later than 4 days after delivery.

- Practical Quality Systems shall not be responsible or liable for any delays, losses or damages caused by strikes, lockouts, labor trouble, acts of war, acts of God, public calamity, or other causes beyond its control, or acts not directly caused by Practical Quality Systems.

Service and Support

For answers to your questions, please email our technicians at **practicalquality@earthlink.net**, or call our office at **(818) 993-1022** Monday to Friday, 9 a.m. to 5 p.m., Pacific Standard Daylight Savings Time.

Mailing Address:

Practical Quality Systems

PO BOX 4624

Chatsworth, CA 91313

www.practicalqualitysystems.com