



PRODUCT MANUAL FOR *EXTENDABLE* SERIES ASSEMBLIES

Wall Mount w/ extendable arm and a screen *pan and tilt head*

PN 80005

Wall Mount w/ 2 extendable arms and two screen *pan and tilt heads*

PN 80007



			
<p>80005</p>	<p>80007</p>		

TABLE OF CONTENTS

	Page
TABLE OF FIGURES	3
1.1 Identifying, configuring and locating the mount for your application	4
1.2 Basic installation steps	4
1.3 Mounting the <i>P1</i> or <i>P3</i> plate on a wall either horizontally or vertically with an <i>Extendable Arm</i>	4
1.4 Reattaching the <i>Extendable Arm</i> to the <i>P1</i> or <i>P3</i> mounting plate installed on a wall either horizontally or vertically.....	5
2.1 Attaching a screen with VESA standard mounting holes.....	5
2.2 Attaching the VESA pan and tilt head to a VESA standard flat panel monitor, touch screen or terminal.....	5
3.1 Attaching the pan and tilt head to the end of the <i>Inner Extension Arm</i>	5
3.3 Adjusting the side to side position of the <i>pan and tilt head</i>	6
3.4 Adjusting the up and down position of the pan and tilt head	6
3.5 Locking the pan and tilt head position for the long term	6
4.1 Changing the side to side position of the entire <i>EX Arm</i> assembly	6
5.1 Extending or retracting the arm	7
6.1 Adjusting the positions of the <i>Offset Brackets (OB)</i>	7
7.1 Reconfiguring the <i>EX Mounting Arm</i> for FLAT mounting on a horizontal surface with standard DOWNWARD angle.....	7
7.2 Reassembling the <i>EX Mounting Arm</i> for FLAT mounting with UPWARD angle configuration	8
8.1 Reconfiguring the <i>EX Arm</i> bracket from standard DOWNWARD angle to UPWARD angle for either WALL or FLAT mounting.....	8
9.1 Reassembling the <i>EX Arm</i> for WALL mounting with UPWARD angle configuration	9
10.1 Monitor or touch screen cabling tips	9

TABLE OF FIGURES

Figure 1 - P1 and P3 plate configurations	10
Figure 2 – EX Arm Mount with VESA pan and tilt head.....	10
Figure 3 - EX Arm Mount with a P1 plate mounted in the horizontal position.....	11
Figure 4 - EX Arm Mount with a P1 plate mounted in the vertical position.....	11
Figure 5 - EX Arm Mount and VESA pan and tilt head adjustment	12
Figure 6 - EX Arm Mount outer extension arm assembly for wall mounting.....	12
Figure 7 - EX Arm Mount outer extension arm assembly for flat mounting	13
Figure 8 - EX Arm Mount.....	14

1.1 Identifying, configuring and locating the mount for your application

PLEASE NOTE: these instructions are for multiple *EXTENDABLE (EX)* product assemblies, refer to the “*List of Figures*” page to locate an exploded view of the assembly that you are using.

All of these assemblies either include the *P1* mounting plate which supports one arm, or the *P3* mounting plate which can support either one or two separate arms.

Start by determining the desired configuration. The standard configuration is with the *P1* or *P3* mounting plate installed Vertically or Horizontally on a WALL, or FLAT on a Horizontal surface (See Figure 1).

If you are attaching the mount in the standard configuration (directly to a wall) refer to sections 1.3 and 1.4.

Alternate configurations are WALL mounted with the arm upward or FLAT mounted with the arm either upward or downward.

If you are reconfiguring your mount for WALL upward, FLAT downward or FLAT upward configurations, please refer to sections 7.1, 8.1, or 9.1.

1.2 Basic installation steps

1. Preassemble the mount for the desired configuration with the pan and tilt head attached but without the equipment installed (See Figure 5).
2. Hold the assembly with the mounting plate against the mounting surface to determine its best location.
3. Pivot the arm so that it can be rotated through its entire range of motion, checking that it does not conflict with the surrounding surfaces. Be sure to take into consideration the additional space that the equipment will need once it is attached to the end of the arm.
4. Once the mounting location has been determined, mark the locations for the fasteners through the flange holes of the mounting plate and follow the installation instructions that are appropriate for your application.

1.3 Mounting the *P1* or *P3* plate on a wall either horizontally or vertically with an *Extendable Arm*

1. The *P1* mounting plate feature one pattern, and the *P3* plate features three rectangular patterns, of four ¼”-20 threaded holes for the insertion of the four mounting screws that attach the *EX Stand-Off Brackets (SB)* and arms to the mounting plate. This mounting screw pattern allows the *EX-SB* brackets and arms to be removed and remounted to the plate if it is installed either vertically or horizontally. In this configuration, the *EX-SB* brackets provide the first pivot point for the arms, allowing them a full range of side to side motion.
2. The mounting screw pattern permits the *EX-SB* bracket and arm to be removed and remounted to the plate if it is installed either vertically (See Figure 4) or horizontally (See Figure 3). When mounting the *P1* plate flat on a wall, either horizontally or vertically, the *EX-SB* bracket provides the first pivot point for the arm, allowing a full range of side to side motion.
3. In many cases, it is easier to remove the *pan and tilt head* from the arm, and then remove the arm with the *EX-SB* bracket from the mounting plate. Then attach the mounting plate alone to the mounting surface.
4. Use extra care to securely attach the mounting plate to the mounting surface with four or more fasteners that are appropriate for the mounting surface material.
5. After the mounting plate is securely attached to the mounting surface, reattach the arm assembly with the *EX-SB* bracket to the plate. Then attach the *pan and tilt head* to the lower *Offset Bracket (OB)* on the end of the arm.

1.4 Reattaching the *Extendable Arm* to the *P1* or *P3* mounting plate installed on a wall either horizontally or vertically

1. The *EX-SB* and *OB* brackets should still be attached to the ends of the arms (See Figure 8). Hold the arm so that the head of the 5/16" bolt is on top of the *EX-SB* bracket. Align the holes in the *EX-SB* bracket with one of the patterns of threaded holes on the *P1* mounting plate.
2. Loosely install the four ¼"-20 Philips securing screws through the *EX-SB* bracket and into the threaded holes in the *P3* mounting plate. Do not fully tighten the screws until all of the screws are threaded into the plate.

2.1 Attaching a screen with VESA standard mounting holes

1. Remove the pan and tilt head from the end of the arm.
2. Remove the arm assembly from the mounting plate.
3. Install the mounting plate and reattach the arm(s).
4. Install the VESA pan and tilt head to the back of the screen.
5. Install the pan and tilt head and the screen together as a unit onto the end of the arm.

2.2 Attaching the VESA pan and tilt head to a VESA standard flat panel monitor, touch screen or terminal

1. Place the unit with the screen facing down on a smooth flat surface and remove the VESA mounting screws from the back of the monitor. If the screws are not present, refer to the unit manual or contact the manufacturer to obtain the correct type and length of screws.
2. Lay the VESA pan and tilt head flat on top of the back of the screen, and align the four holes in the VESA pan and tilt head with the pattern of four threaded holes on the back of the screen.
3. Loosely install the four screws through the VESA pan and tilt head and into the threaded holes on the back of the screen. Do not fully tighten the screws until all of the screws are threaded into the back of the screen.

3.1 Attaching the pan and tilt head to the end of the *Inner Extension Arm*

1. Lay the anti-slip washer on top of the end of the arm (See Figure 8).
2. Check that the bottom of the pan and tilt head is flat and that the four point tilt knobs are tightened enough so that the pan and tilt head cannot move easily (See Figure 5).
3. Carefully lift the monitor and center the bottom hole of the pan and tilt head over the hole in the end of the arm.
4. Gently lower the monitor until the bottom of the pan and tilt head is resting slightly on the end of the arm. Do not release your grip on the monitor.
5. Hold the five-pointed knob so that the threaded shaft is pointing up and it is under the end of the arm. Guide the knob shaft up through the hole in the end of the arm, and through the anti slip washer until it contacts the center of the threaded hole in the bottom of the pan and tilt head (See Figure 5).
6. Carefully turn the knob to thread it into the bottom of the pan and tilt head. Tighten the knob until the bottom of the pan and tilt head is pulled snugly against the top of the end of the arm.
7. Verify that the end of the threaded shaft of the knob can be seen inside of the nut on the bottom of the pan and tilt head. Do not release your grip on the monitor until you have verified that the pan and tilt head is correctly attached to the end of the arm.

3.3 Adjusting the side to side position of the *pan and tilt head*

1. Carefully and firmly grasp the monitor at the top center of the screen to support its entire weight.
2. Slightly loosen the large five point knob below the lower OB bracket just enough so that the pan and tilt head will turn (See Figure 5).
3. While still firmly holding the monitor, slowly rotate it to the desired position and then tighten the locking knob securely.

3.4 Adjusting the up and down position of the pan and tilt head

1. Carefully and firmly grasp the monitor at the top center of the screen to support its entire weight.
2. Slightly loosen both of the four point knobs on both sides of the pan and tilt head just enough so that the monitor can be moved up and down slightly (See Figure 5).
3. While still firmly holding the monitor, slowly raise or lower it to the desired position and then tighten both of the locking knobs securely.

3.5 Locking the pan and tilt head position for the long term

In most cases, firm tightening of the three locking knobs on the pan and tilt head will sufficiently hold the desired side to side and up and down position of the screen. If your application requires additional security to hold the desired screen position, the pan and tilt head can be more securely locked by slightly tightening the pan and tilt head locking screws. **PLEASE NOTE:** if the factory setting of the locking screws is changed, they must be reset to return the pan and tilt head to normal function.

Follow the steps below to lock the pan and tilt head in place for the long term:

1. Adjust the pan and tilt head as described in the instructions to hold the screen at the desired position.
2. Tighten the three locking knobs as firmly as possible using only your hands.
3. Using a standard Philips type screwdriver, gently tighten the two locking screws on the sides of the pan and tilt head and the single locking screw on the bottom of the pan and tilt head (See Figure 5).

To reset the original position of the *pan and tilt head* locking screws:

1. First, support the entire weight of the screen. Doing one at a time, carefully loosen the locking screws until only three threads at the end of the screw shaft can be seen protruding through the metal next to the anti-slip washer (See Figure 5).
2. The correct length of the protruding end of the locking screw is set when there is no weight on the pan and tilt head and the knob is tightened slightly only until there is no space between the metal surfaces and the anti slip washers. With this knob pretension set, the protruding end of the locking screw should be set just back of where it would contact the opposing metal surface by approximately 1/32".

4.1 Changing the side to side position of the entire *EX Arm* assembly

1. Unscrew the large three pointed knob and withdraw it completely from the top of the Upper OB bracket (See Figure6).
2. Rotate the entire arm assembly to the desired new position.
3. Align the hole on the top of the upper *OB* bracket with one of the holes in the *EX-SB* bracket which is closest to the desired position.
4. Reinsert the threaded shaft of the knob through the aligned holes on the top of the *OB* and *EX-SB* brackets and into the threaded hole on the bottom of the *EX-SB* bracket. Turn the knob slowly clockwise with a slight downward pressure to thread the knob into the *EX-SB*. If the threads of the knob do not engage properly, try lifting and gently shaking the arm slightly while you turn the knob to help guide the threads together.

5.1 Extending or retracting the arm

1. Carefully and firmly grasp the monitor below the center of the screen to support its entire weight.
2. Slightly loosen the small three pointed knob on the side of the middle of the arm until the inner and outer arms will slide over each other (See Figure 2). To retract the arm, lift the screen and guide it smoothly upwards to the desired position, then tighten the locking knob securely.
3. To extend the arm, lift the screen and guide it smoothly outwards to the desired position, then tighten the locking knob securely.

6.1 Adjusting the positions of the *Offset Brackets (OB)*

1. The offset angles of the *OB* brackets must be set equally so that the upper and lower *OB* brackets are kept in parallel to each other (See Figure 2). For example: if you adjust the upper bracket two holes down, you must adjust the lower bracket two holes up.
2. Carefully and firmly grasp the monitor below the center of the screen to support its entire weight.
3. Carefully lift the safety clip of the locking pin on the upper *OB* bracket and withdraw the locking pin from the bracket.
4. Carefully raise or lower the entire arm assembly to align the holes in the arm with the holes in the *OB* bracket which are closest to the desired new position. Reinsert the locking pin and reset the safety clip over the end of the pin.

7.1 Reconfiguring the *EX Mounting Arm* for **FLAT** mounting on a horizontal surface with standard **DOWNWARD** angle.

1. Place the entire assembly on a flat surface. Remove the five point knob from the lower *OB* bracket. Remove the anti-slip washer and the entire pan and tilt head unit (See Figure 2).
2. Remove the three-pointed knob from the front of the side of the *EX-Arm* bracket.
3. Using a ½" nut driver or socket, remove the 5/16"-18 X 1 ¾" length bolt from the top center of the *EX-SB* bracket.
4. Remove the plastic spacer from the inside of the upper *OB* bracket and pull the *EX-SB* bracket and the *P1* mounting plate apart from the upper *OB* bracket.
5. Using a Philips screwdriver, remove the four ¼"-20 X ¾" long Philips screws that hold the *EX-SB* Bracket to the *P1* mounting plate. (These four screws and the *EX-SB* bracket will not be used in this configuration)
6. Hold the *Extension* part of the assembly so that the bottom of the upper *OB* bracket is flat against the top of the *P1* mounting plate. Align the center holes of the upper *OB* bracket and the *P1* mounting plate (See Figure 7).
7. Place the plastic spacer inline with the holes on the inside of the upper *OB* bracket. Insert the 5/16"-18 X 1 ¾" length bolt into the top center of the *OB* bracket, through the plastic spacer and thread the bolt into the center hole of the *P1* mounting plate (See Figure 8).
8. Tighten the bolt only enough so as to remove any space between the plastic spacer and the inside surfaces of the Upper *OB* bracket. The *EX* bracket and *OB* brackets should be able to pivot without much resistance.
9. Reinstall the three pointed knob into the top front of the *EX-SB* bracket and into the *P1* mounting plate.
10. If you are using a screen with VESA standard mounting holes, install the *pan and tilt head* on the back of the screen first, then reinstall the *pan and tilt head* and the screen together as a unit on the lower *OB* bracket.

11. If you are installing a screen which has a proprietary tab or keyhole mounting system on the back, install the *pan and tilt head* on the end of the lower *OB* bracket, then install the screen onto the pan and tilt head.

7.2 Reassembling the *EX Mounting Arm* for FLAT mounting with UPWARD angle configuration

1. Using a Philips screwdriver, remove the four ¼"-20 X ¾" length Philips screws that hold the *EX-SB* Bracket to the *P1* mounting plate. (These four screws and the *EX-SB* bracket will not be used in this configuration)
2. Hold the *Extension* part of the assembly so that the tape marker on the *OB* bracket is facing down, place the *OB* bracket on top of the center hole in the *P1* mounting plate and align the center holes of both brackets (See Figure 8).
3. Place the plastic spacer inline with the holes on the inside of the upper *OB* bracket and insert the 5/16"-18 X 1 ¾" length bolt into the center top of the *OB* bracket, through the plastic spacer, and thread the bolt into the center hole of the *P1* mounting plate (See Figure 8).
4. Tighten the bolt only enough so as to remove any space between the plastic spacer and the inside surfaces of the upper *OB* bracket. The *EX-SB* bracket and *OB* brackets should be able to pivot without much resistance.
5. Thread the bolt into the bottom of the *EX-SB* bracket and tighten it only enough to remove any space between the plastic spacer and the inside surfaces of the upper *OB* bracket. The *OB* bracket and the *P1* mounting plate should be able to pivot without much resistance.
6. Reinstall the three pointed knob into the top front of the *EX-SB* bracket and into the *P1* mounting plate.
7. If you are using a screen with VESA standard mounting holes, install the pan and tilt head on the back of the screen first, then reinstall the pan and tilt head and the screen together as a unit on the lower *OB* bracket.
8. If you are installing a screen which has a proprietary tab or keyhole mounting system on the back, install the pan and tilt head on the lower end of the *OB* bracket. Then install the screen onto the pan and tilt head.

8.1 Reconfiguring the *EX Arm* bracket from standard DOWNWARD angle to UPWARD angle for either WALL or FLAT mounting

1. Place the entire assembly on a flat surface, remove the five point knob from the lower *OB* bracket, remove the anti slip washer and the entire pan and tilt head together as a unit (See Figure 2).
2. Remove the three pointed knob from the top front of the *EX-SB* bracket (See Figure 6).
3. Using a ½" nut driver or socket, remove the 5/16"-18 X 1 ¾" length bolt from the top center of the *EX-SB* bracket.
4. Remove the plastic spacer from the inside of the upper *OB* bracket, and pull the *EX-SB* bracket and the *P1* mounting plate apart from the upper *OB* bracket (See Figure 6).
5. Place small pieces of tape on the top of both *OB* brackets and on the top of both arm sections. The tape is used as a marker the top faces of these components.
6. Remove the three point knob from the side of the arm and separate the arm sections.
7. Remove the locking pins from the *OB* brackets on both the upper and lower arm sections (See Figure 2).
8. Using a 7/16" nut driver or socket, loosen the ¼"-20 X 1 ¾" length bolt from the lower *OB* Bracket.

9. Remove the bolt while being careful not to loosen the two black plastic spacers which are located between the inner sides of the lower *OB* bracket and the arm.
10. Turn the lower *OB* bracket over so that now the side with the tape marker is facing down, and the tape marker on the arm is facing up. Reinstall the bolt, spacers, and safety lock pin.
11. Using a 7/16" nut driver or socket, loosen the 1/4"-20 X 1 3/4" length bolt from the upper *OB* Bracket and remove it.
12. Turn the upper *OB* bracket over so that the side with the tape marker is facing down, and the tape marker on the arm is facing up. Reinstall the bolt, spacers and safety lock pin.

9.1 Reassembling the *EX Arm* for WALL mounting with UPWARD angle configuration

1. Slide the upper *OB* into the *EX-SB* bracket with the *P1* plate and align the center holes of both brackets (See Figure6).
2. Hold the plastic spacer inline with the holes on the inside of the upper *OB* bracket. Slide the 5/16"-18 X 1 3/4" length bolt in from the top of the *EX-SB* bracket, all the way through the upper *OB* bracket and the plastic spacer.
3. Thread the bolt into the bottom of the *EX-SB* bracket and tighten it only enough so as to remove any space between the plastic spacer and the inside surfaces of the upper *OB* bracket. The *EX-SB* bracket and *OB* brackets should be able to pivot without much resistance.
4. Reinstall the three-pointed knob into the top front of the *EX-SB* bracket.
5. If you are using a screen with VESA standard mounting holes, install the pan and tilt head on the back of the screen first. Then reinstall the pan and tilt head and the screen together as a unit on the lower *OB* bracket.
6. If you are installing a screen which has a proprietary tab or keyhole mounting system on the back, install the pan and tilt head on the lower end of the *OB* bracket, then install the screen onto the pan and tilt head.

10.1 Monitor or touch screen cabling tips

Route the data, power and other cables and connect them loosely to the screen. After testing your screen for correct operation, use small plastic cable ties, or hook and loop ties, to attach the cables to the plastic roller behind the middle of the pan and tilt head so that the cable connectors will not be strained when the printer is repositioned. Then with more ties, form the screen cables into a single bundle, creating a cable leash that extends from a point near the mounting plate location to the rear of the pan and tilt head. Be sure to leave enough slack cable so that the printer can be moved through its entire range of motion.

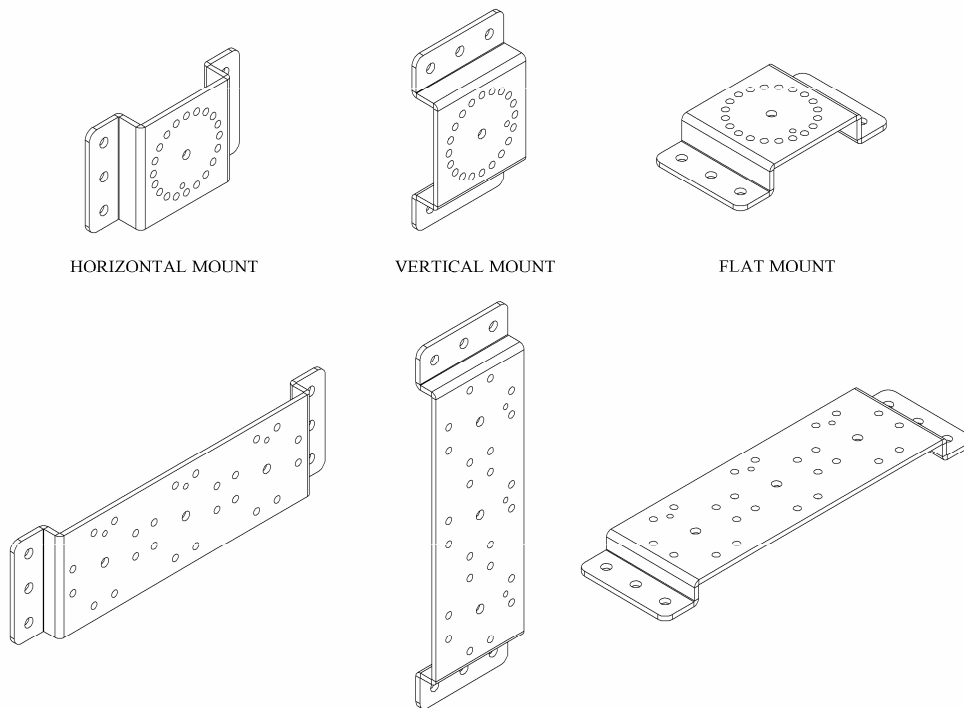

Figure 1 - P1 and P3 plate configurations

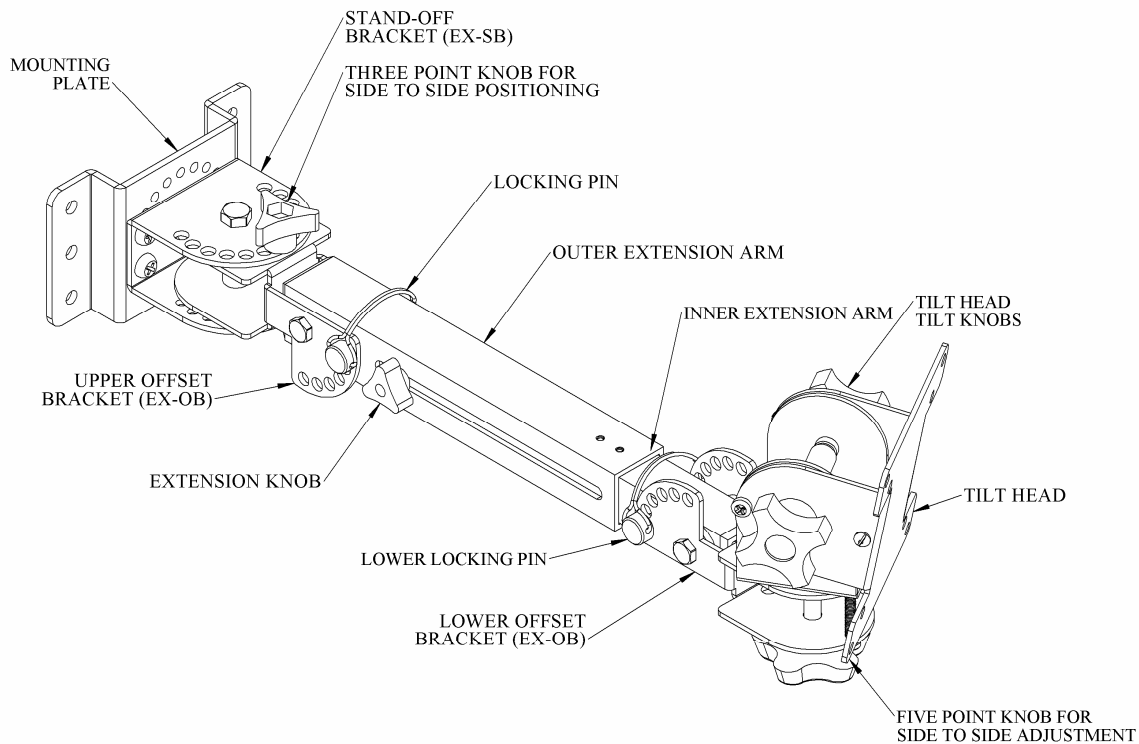

Figure 2 – EX Arm Mount with VESA pan and tilt head

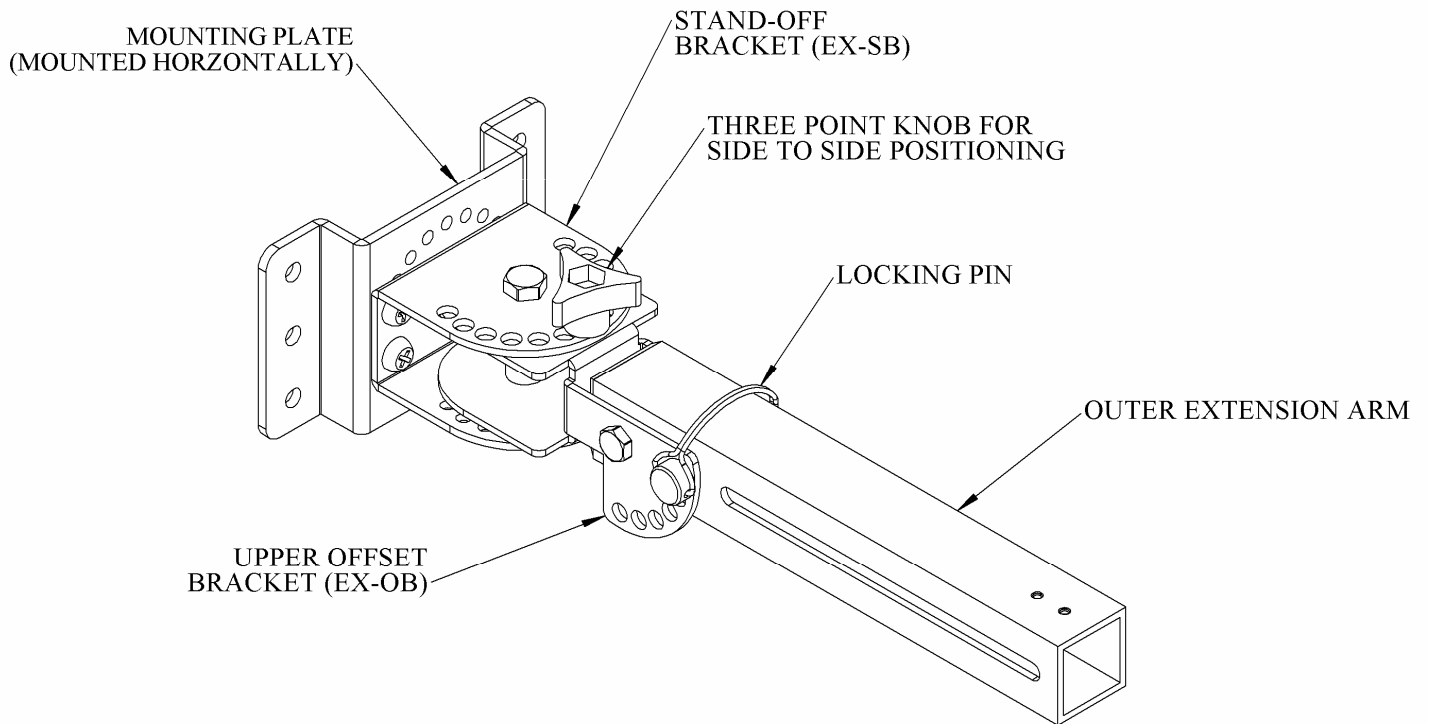

Figure 3 - EX Arm Mount with a P1 plate mounted in the horizontal position

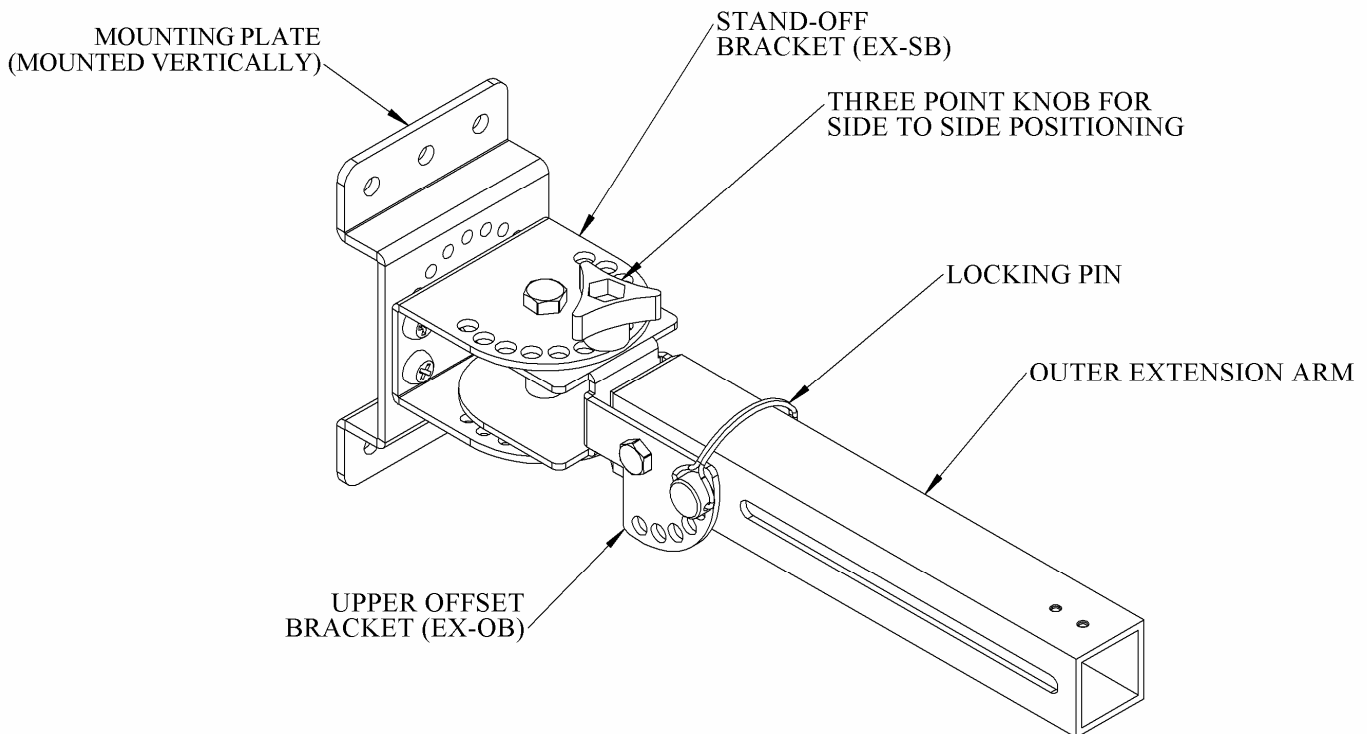

Figure 4 - EX Arm Mount with a P1 plate mounted in the vertical position

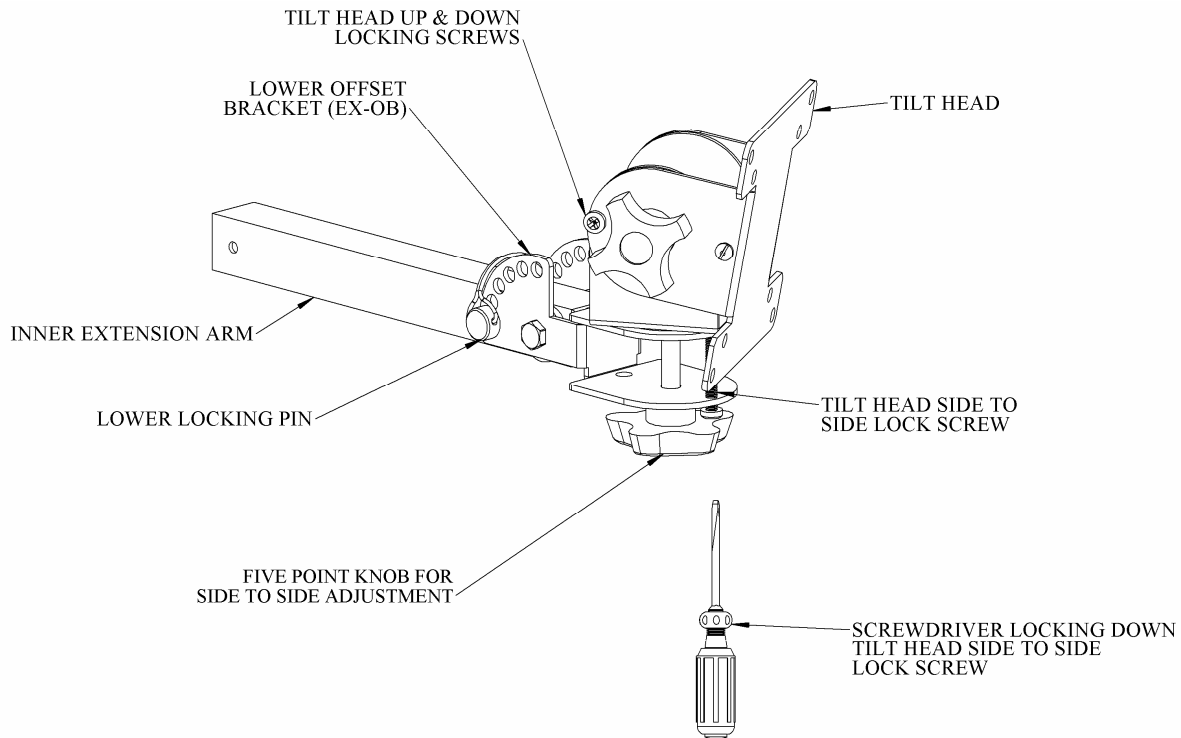

Figure 5 - EX Arm Mount and VESA pan and tilt head adjustment

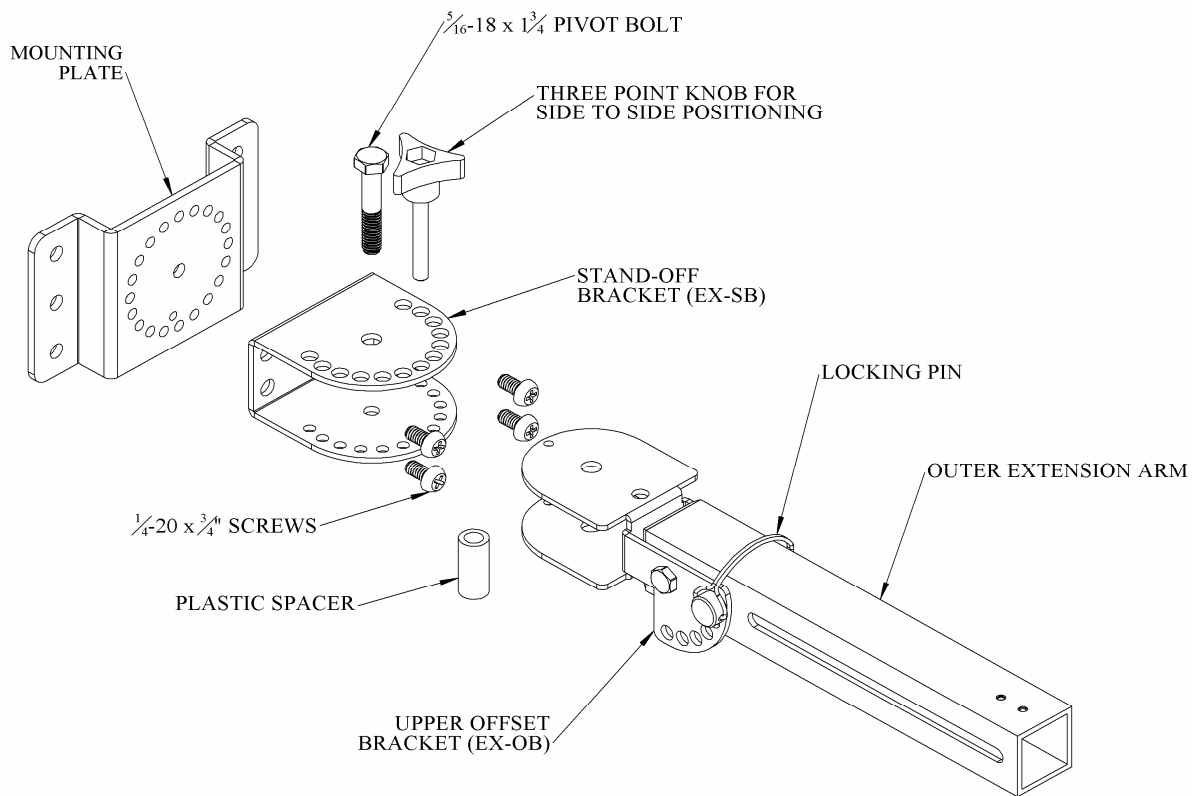

Figure 6 - EX Arm Mount outer extension arm assembly for wall mounting

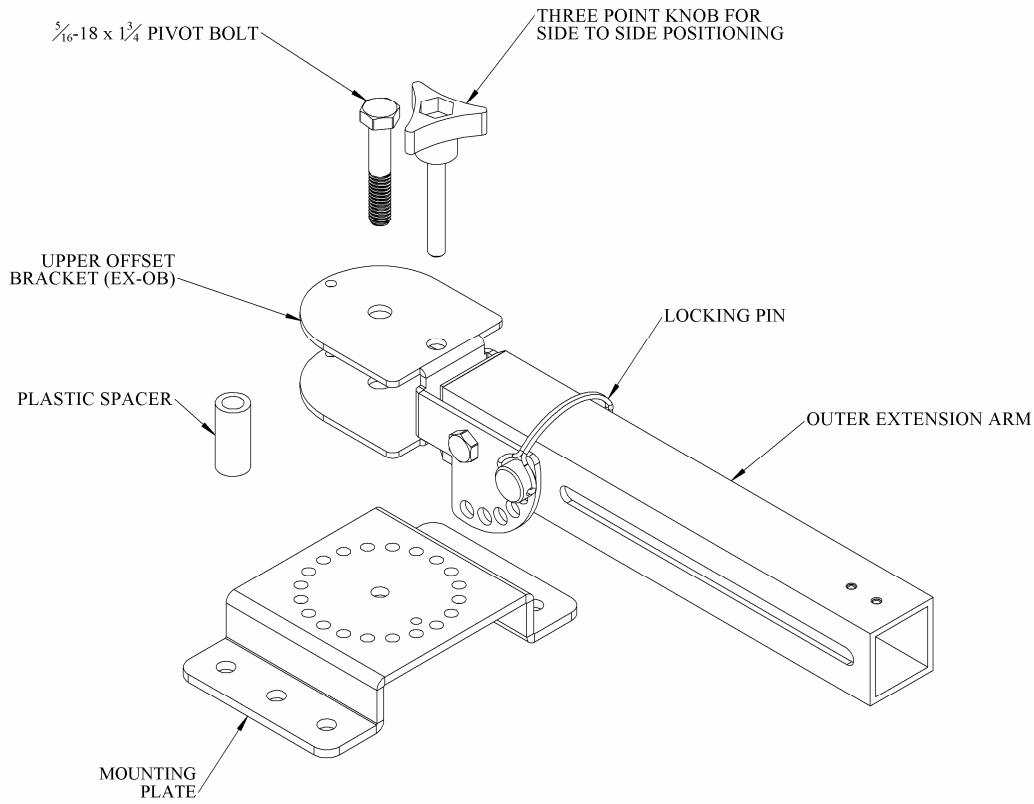
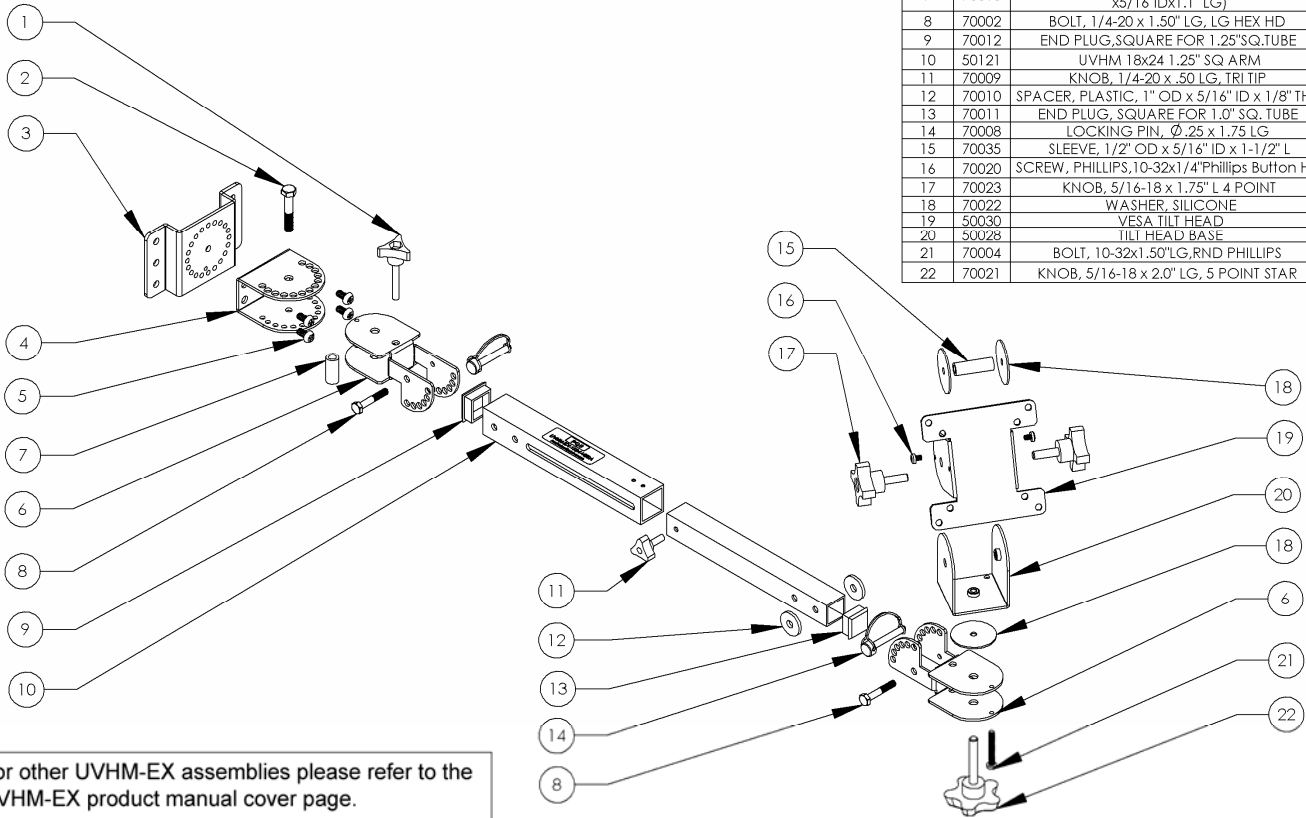

Figure 7 - EX Arm Mount outer extension arm assembly for flat mounting

UVHM-EX-18-24-VESA P/N 80005

A single position plate with one extendable arm and a VESA tilt head

ITEM #	PART #	DESCRIPTION	QTY.
1	70001	KNOB, 1/4-20 x 1.75" LG TRI TIP	1
2	70003	BOLT, 5/16-18 x 1.75" LG HEX HD	1
3	50127	UVHM SINGLE MOUNT PLATE	1
4	50125	UNIVERSAL VERT. & HORIZ. MOUNT SYSTEM EXTENDABLE ARM STAND-OFF BRACKET	1
5	70000	BOLT, 1/4-20 x .50" LG, RND PHILLIPS	4
6	50130	UVHM OFFSET BRACKET	2
7	70013	SPACER, PVC SCHED. 40(1/2"OD x5/16"IDx1.1" LG)	1
8	70002	BOLT, 1/4-20 x 1.50" LG, LG HEX HD	2
9	70012	END PLUG, SQUARE FOR 1.25" SQ. TUBE	1
10	50121	UVHM 18x24 1.25" SQ ARM	1
11	70009	KNOB, 1/4-20 x .50 LG, TRI TIP	1
12	70010	SPACER, PLASTIC, 1" OD x 5/16" ID x 1/8" THK	2
13	70011	END PLUG, SQUARE FOR 1.0" SQ. TUBE	1
14	70008	LOCKING PIN, Ø.25 x 1.75 LG	2
15	70035	SLEEVE, 1/2" OD x 5/16" ID x 1-1/2" L	1
16	70020	SCREW, PHILLIPS, 10-32x1/4" Phillips Button Hd	2
17	70023	KNOB, 5/16-18 x 1.75" L 4 POINT	2
18	70022	WASHER, SILICONE	3
19	50030	VESA TILT HEAD	1
20	50028	TILT HEAD BASE	1
21	70004	BOLT, 10-32x1.50" LG, RND PHILLIPS	1
22	70021	KNOB, 5/16-18 x 2.0" LG, 5 POINT STAR	1



For other UVHM-EX assemblies please refer to the UVHM-EX product manual cover page.

Figure 8 - EX Arm Mount