



PRACTICAL QUALITY SYSTEMS  
*Fast Custom Manufacturing - Nationwide Installation Services*

## PRODUCT MANUAL FOR *UNDER COUNTER MOUNTS w/RISER SERIES ASSEMBLIES*

<i>Under Counter Mount w/ 6" riser, 8" arm, and a screen pan and tilt head</i>	PN 80240
<i>Under Counter Mount w/ 3" riser, 8" arm, and a screen pan and tilt head</i>	PN 80241
<i>Under Counter Mount w/ 6" riser, 8" arm, and a universal printer mounting tray</i>	PN 80244
<i>Under Counter Mount w/ 3" riser, 8" arm, and a universal printer mounting tray</i>	PN 80245
<i>Dual Under Counter Mount w/ 2- 6" risers w/8" arms, a screen pan and tilt head, and universal printer mounting tray</i>	PN 80246
<i>Dual Under Counter Mount w/ 2- 3" risers w/8" arms, a screen pan and tilt head, universal printer mounting tray</i>	PN 80247
<i>Under Counter Mount w/ 3" and 6" risers w/8" arms, a screen pan and tilt head, universal printer mounting tray</i>	PN 80248

**TABLE OF CONTENTS**

**1.1 Identifying, configuring and locating the mount for your application.....4**

**1.2 Basic installation steps.....4**

**2.1 Installing the *Under Counter Mounting Plate*.....4**

**3.1 Basic steps for installing a screen with VESA standard mounting holes.....5**

**3.2 Attaching the VESA pan and tilt head to a VESA standard flat panel monitor, touch screen or terminal.....5**

**3.3 Basic steps for installing a *Universal Printer Mounting Tray*.....5**

**4.1 Attaching a pan and tilt head or *Universal Printer Mounting Tray* to the end of the arm .....5**

**4.2 Adjusting the side to side position of a pan and tilt head or *Universal Printer Mounting Tray*.....6**

**4.3 Adjusting the up and down position of the pan and tilt head .....6**

**5.1 Locking the pan and tilt head position for the long term .....6**

**6.1 Adjusting the Pan and Tilt head stop .....7**

**7.1 Adjusting the side to side position of the arms on top of the *Riser*.....7**

**8.1 Adjusting the *Riser Stop*.....7**

**9.1 Installing and adjusting the *UPMT (Universal Printer Mounting Tray)*.....8**

**9.2 *Universal Printer Mounting Tray* cabling tips for assemblies with risers .....8**

**9.3 Monitor or touch screen cabling tips for assemblies with risers .....8**

## TABLE OF FIGURES

---

Figure 1 - <i>Under Counter Mount w/ 6" riser, 8" arm, and a screen pan and tilt head (PN 80240)</i> .....	9
Figure 2 - <i>VESA Pan and Tilt Head on 8" Arm</i> .....	9
Figure 3 – <i>Universal Printer Mounting Tray (UPMT) on 8" Arm</i> .....	10
Figure 4 – <i>Under Counter Mounting Plate with Mounting Screws</i> .....	10
Figure 5 - <i>Under Counter Mount w/ 6" Riser, 8" Arm, and a Screen Pan and Tilt Head exploded parts view (PN 80240)</i> .....	11

## 1.1 Identifying, configuring and locating the mount for your application

**PLEASE NOTE:** these instructions are for multiple *Under Counter w/Riser* assemblies, refer to the “List of Figures” page to locate an exploded view of the assembly that you are using.

All of these assemblies are *Under Counter Mount with Riser* types **which can support either one or two separate risers with arms.**

## 1.2 Basic installation steps

1. Preassemble the mount for the desired configuration with the pan and tilt head and/or *Universal Printer Mounting Tray* attached, but without the equipment installed (See Figure 1).
2. Hold the assembly with the mounting plate against the mounting surface to determine its best location.
3. Pivot the arms so that they can be rotated through their entire range of motion and do not conflict with the surrounding surfaces. Be sure to take into consideration the additional space that the equipment will need once it is attached to the end(s) of the arm(s).
4. Consider where the *riser stop* should best be located to permit the optimum range of motion. If the riser's stop position needs to be adjusted, refer to section 8.1 and adjust the *riser stop* position as needed before attaching the mounting plate to the mounting surface.
5. Once the mounting location has been determined, mark the locations for the fasteners through the holes on the mounting plate. Follow the installation instructions that are appropriate for your application.

## 2.1 Installing the *Under Counter Mounting Plate*

1. The *Under Counter Mounting Plates* feature three repeating patterns of ¼”-20 threaded holes for the insertion of the four mounting screws that attach the *Support Brackets* with the risers and arms to the mounting plate. The mounting screw pattern allows the *Support Brackets* with the risers and arms to be removed and remounted to the plate. The risers provide the first pivot point for the arms allowing them a full range of side to side motion. The arms are attached to the top of the riser with a 5/16” bolt that is secured with thread locking compound, and is not intended to be removed or adjusted in the field.
2. Remove the pan and tilt heads and/or the *Universal Printer Mounting Tray* from the arm(s).
3. Remove the arm(s) with the *Support Brackets* from the mounting plate.
4. Securely attach the mounting plate to the mounting surface with several fasteners that are appropriate for the materials of the mounting surface (See Figure 4).

### Reattaching the arms to the mounting plate

1. The *Support Brackets* with the risers should still be attached to the ends of the arms. Hold the riser so that the arm is on top and the *Support Bracket* is on the bottom. Align the holes in the *Support Bracket* with one of the patterns of threaded holes on the mounting plate (See Figure 1).
2. Loosely install the four ¼”-20 Philips securing screws through the *Support Bracket* and into the threaded holes in the mounting plate. Do not fully tighten the screws until all of the screws are threaded into the plate.

### 3.1 Basic steps for installing a screen with VESA standard mounting holes

1. Remove the pan and tilt head from the end of the arm.
2. Install the mounting plate complete with the riser(s) and arm(s).
3. Install the VESA pan and tilt head to the back of the screen.
4. Install the pan and tilt head and the screen together as a unit onto the end of the arm.

### 3.2 Attaching the VESA pan and tilt head to a VESA standard flat panel monitor, touch screen or terminal

1. Place the unit with the screen facing down on a smooth flat surface and remove the VESA mounting screws from the back of the monitor. If the screws are not present, refer to the unit manual or contact the manufacturer to obtain the correct type and length of screws.
2. Lay the VESA pan and tilt head flat on top of the back of the screen, and align the four holes in the VESA pan and tilt head with the pattern of four threaded holes on the back of the screen.
3. Loosely install the four screws through the VESA pan and tilt head and into the threaded holes on the back of the screen. Do not fully tighten the screws until all of the screws are threaded into the back of the screen.

### 3.3 Basic steps for installing a *Universal Printer Mounting Tray*

1. Remove the *Universal Printer Mounting Tray (UPMT)* from the end of the arm.
2. Install the mounting plate complete with the riser(s) and arm(s).
3. Install the *UPMT* on the end of the arm (See Figure 3).
4. Install the printer on the *UPMT*.

### 4.1 Attaching a pan and tilt head or *Universal Printer Mounting Tray* to the end of the arm

1. Lay the silicone anti-slip washer on top of the end of the arm (See Figure 5).
2. Check that the bottom of the pan and tilt head is flat and that the four point tilt knobs are tightened enough so that the tilt head cannot move easily.
3. Carefully lift the monitor or *UPMT* and center the bottom hole of the pan and tilt head or tray over the hole in the end of the arm.
4. Gently lower the monitor until the bottom of the tilt head is resting slightly on the end of the arm. Do not release your grip on the monitor or *UPMT*.
5. Hold the five pointed knob so that the threaded shaft is pointing up and it is under the end of the arm. Guide the knob shaft up through the hole in the end arm and through the anti slip washer until it contacts the center of the threaded hole in the bottom of the pan and tilt head or *UPMT*.
6. Carefully turn the knob to thread it into the bottom of the pan and tilt head or tray until the bottom of it is pulled snugly against the top of the end of the arm.
7. Verify that the end of the threaded shaft of the knob can be seen inside of the nut on the bottom of the pan and tilt head or *UPMT*. Do not release your grip on the monitor until you have verified that the pan and tilt head or *UPMT* is correctly attached to the end of the arm.

#### 4.2 Adjusting the side to side position of a pan and tilt head or *Universal Printer Mounting Tray*

1. Carefully and firmly grasp the monitor or printer at the top center of the unit to support its entire weight.
2. Slightly loosen the large five point knob below the end of the arm just enough so that the pan and tilt head or *Universal Printer Mounting Tray (UPMT)* will turn (See Figure 2).
3. While still firmly holding the monitor or printer, slowly rotate it to the desired position and then tighten the locking knob securely.

#### 4.3 Adjusting the up and down position of the pan and tilt head

1. Carefully and firmly grasp the monitor at the top center of the screen to support its entire weight.
2. Slightly loosen both of the four point knobs on both sides of the pan and tilt head just enough so that the monitor can be moved up and down slightly (See Figure 2).
3. While still firmly holding the monitor, slowly raise or lower it to the desired position and then tighten both of the locking knobs securely.

#### 5.1 Locking the pan and tilt head position for the long term

In most cases, firm tightening of the three locking knobs on the pan and tilt head will sufficiently hold the desired side to side and up and down position of the screen. If your application requires additional security to hold the desired screen position, the pan and tilt head can be more securely locked by slightly tightening the pan and tilt head locking screws.

**PLEASE NOTE:** if the factory setting of the locking screws is changed, they must be reset to return the pan and tilt head to normal function.

##### **Follow the steps below to lock the pan and tilt head in place for the long term:**

1. Adjust the pan and tilt head as described in the instructions to hold the screen at the desired position.
2. Tighten the three locking knobs as firmly as possible using your hands only.
3. Using a standard Philips screwdriver, gently tighten the two locking screws on the sides of the pan and tilt head, and the single locking screw on the end of the arm under the bottom of the pan and tilt head (See Figure 2).

##### **To reset the original position of the tilt head locking screws:**

1. Support the entire weight of the screen. Doing one at a time, carefully loosen the locking screws until only three threads of the end of the screw shaft can be seen protruding through the metal next to the silicone anti-slip washer.
2. The correct length of the protruding end of the locking screw is set when there is no weight on the pan and tilt head and the knob is tightened slightly until there is no space between the metal surfaces and the silicone anti-slip washers. With this knob pretension set, the protruding end of the locking screw should be set just back of where it would contact the opposing metal surface by approximately 1/32.”

## 6.1 Adjusting the Pan and Tilt head stop

The pan and tilt head stop keeps the pan and tilt head from doing a full rotation around the end of the arm (See Figure 1). This protects the cabling that connects to the equipment from being wrapped around the pan and tilt head and possibly becoming damaged. The pan and tilt head is set at the factory to prevent the arm from being rotated one entire revolution to the left. If this setting does not work for your application, the riser stop can be easily removed from the bottom of the pan and tilt head with a Philips screwdriver and installed on the other side.

## 7.1 Adjusting the side to side position of the arms on top of the *Riser*

1. Slightly loosen the three point knob on the side of the *Riser Cap* enough so that the arm will move freely (See Figure 1).
2. Carefully move the equipment with the arm to the new position and then retighten the five point knob to secure the arm.

## 8.1 Adjusting the *Riser Stop*

The riser stop keeps the arm from doing a full rotation around the *riser* (See Figure 1). This protects the cabling that connects to the equipment from being wrapped around the *riser* and possibly becoming damaged. The *riser stop* is set at the factory to prevent the arm from being rotated one entire revolution to the left. If this setting does not work for your application, the *riser stop* can be easily adjusted.

### Adjusting the *riser stop* for the “optimum range of motion”

1. Consider the entire range of motion possible for the arms that support the equipment.
2. Establish all of the best locations where the equipment will be moved to and used.
3. This is the “optimum range of motion” for your application.
4. If unrestricted, the arm would make a complete circle around the riser. The “optimum range of motion” occupies at least one half of the circle and the *riser stop* should be placed exactly opposite to the middle of the optimum range on the other half of the circle.

### To adjust the position of the *riser stop*

1. Disconnect any cabling that is connected to the equipment.
2. Using a Philips screwdriver, remove the *riser stop screw* and *plastic spacer* from the side of the *riser*.
3. Using a Philips screwdriver, slightly loosen the *riser locking screw* on the bottom of the *Support Bracket* just enough so that the *riser* can be rotated.
4. Grasp the riser carefully and slowly rotate it the minimum amount so that the stop is located on the opposite side of the middle of the “optimum range of motion” for your application.
5. Carefully re-tighten the *riser locking screw* just enough to keep the *riser* from turning under normal use.
6. Reinstall the *riser stop screw* and *spacer* in the side of the *riser*.
7. Test the range of motion and adjust as necessary.

### 9.1 Installing and adjusting the *UPMT (Universal Printer Mounting Tray)*

The width of the *UPMT* will expand to support printers from 5" to 9 ½" wide. To extend or retract the sides of the *UPMT*, turn one of the small round knobs on either of the sides on the middle of the *UPMT* until the desired width is adjusted (See Figure 4).

The *UPMT* will tilt from the level position to 30 degrees forward. To adjust the forward tilt, carefully loosen the two three-pointed knobs which are on each side of the front of the *UPMT*. Raise or lower the rear of the *UPMT* to the desired tilt angle and tighten the knobs to secure the tilt position. Be advised, some types of printers will erroneously indicate that they are low on printing paper when they are tilted too far forward.

### 9.2 *Universal Printer Mounting Tray* cabling tips for assemblies with risers

Route the data and power cables and connect them loosely to the printer. After testing your printer for correct operation, use small plastic cable ties, or hook and loop ties, to attach the cables to the metal tie loops at the rear of the *Universal Printer Mounting Tray*, be sure that the cable connectors will not be strained when the printer repositioned. Then with more ties, form the printer cables into a single bundle to create a cable leash that extends from the rear of the *UPMT*, to the tie point on the top of the riser cap, and then down to a point near the mounting plate location. Be sure to leave enough slack cable so that the printer can be moved through its entire range of motion around the end of the arm, AND so that the arm can be moved around the top of the *riser cap*.

### 9.3 Monitor or touch screen cabling tips for assemblies with risers

Route the data, power, and other cables and connect them loosely to the screen. After testing your screen for correct operation, attach the cables to the plastic roller behind the middle of the pan and tilt head so that the cable connectors will not be strained when the screen is repositioned. Using small plastic cable ties, or hook and loop ties, form the cables into a single bundle to create a cable leash that extends from the rear of the pan and tilt head, to the tie point on the top of the *riser cap*, and then down to a point near the mounting plate location. Be sure to leave enough slack cable so that the equipment can be moved through its entire range of motion around the end of the arm, AND so that the arm can be moved around the top of the *riser cap*.

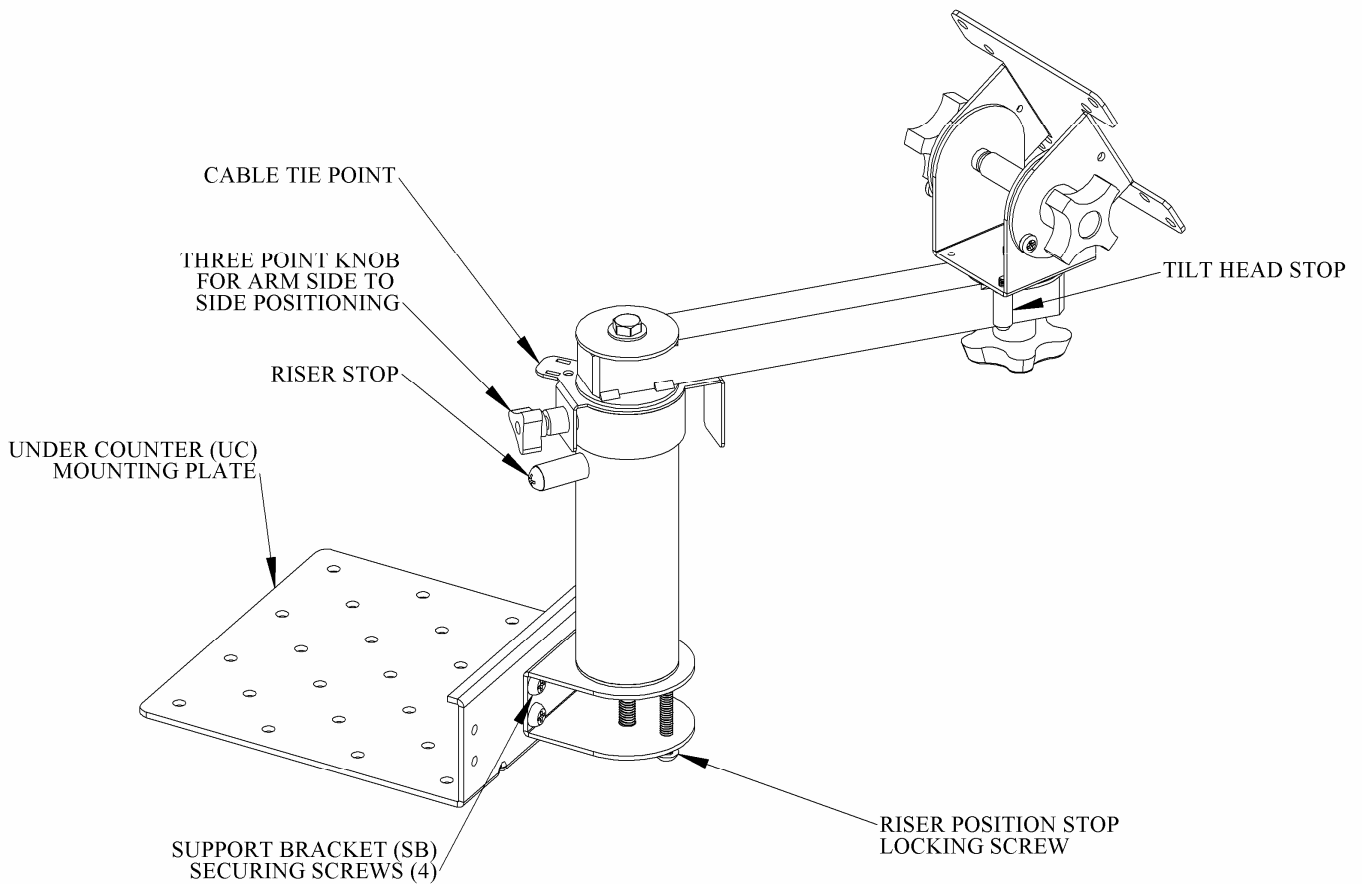

**Figure 1 - Under Counter Mount w/ 6" riser, 8" arm, and a screen pan and tilt head (PN 80240)**

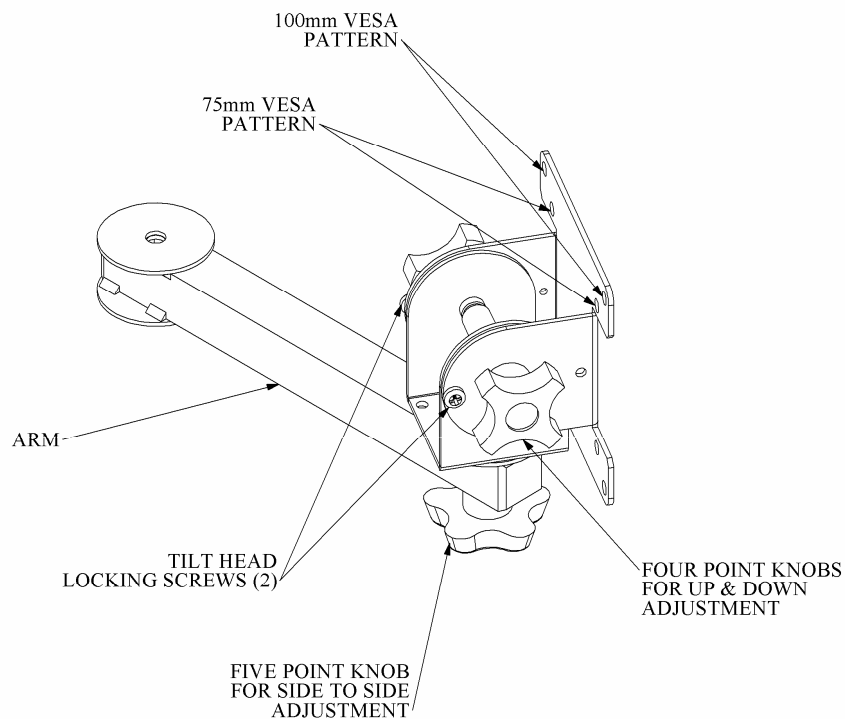

**Figure 2 - VESA Pan and Tilt Head on 8" Arm**

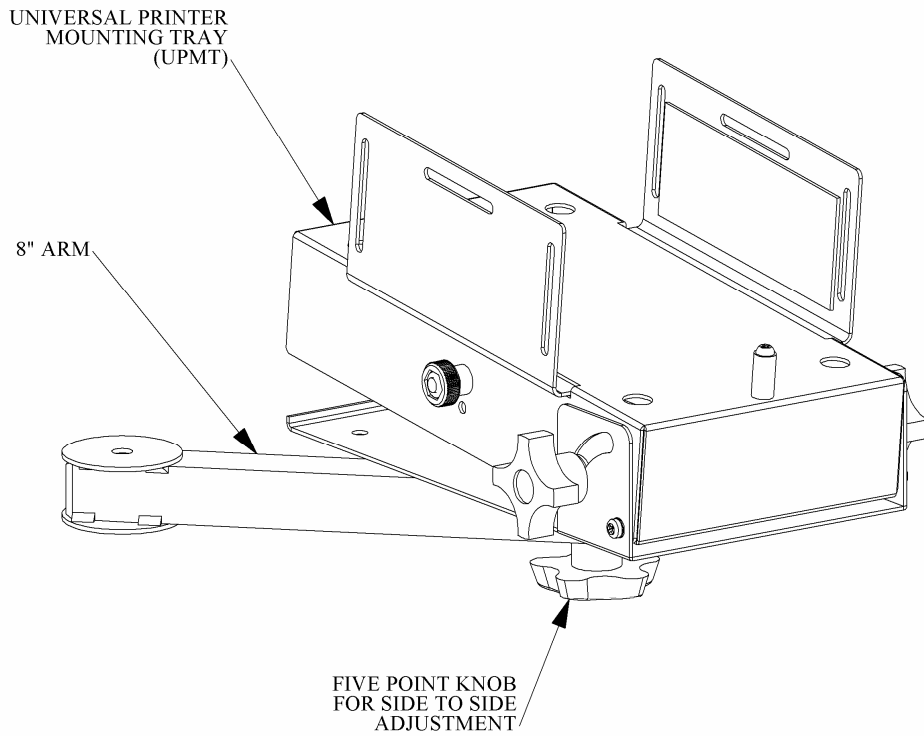

**Figure 3 – Universal Printer Mounting Tray (UPMT) on 8" Arm**

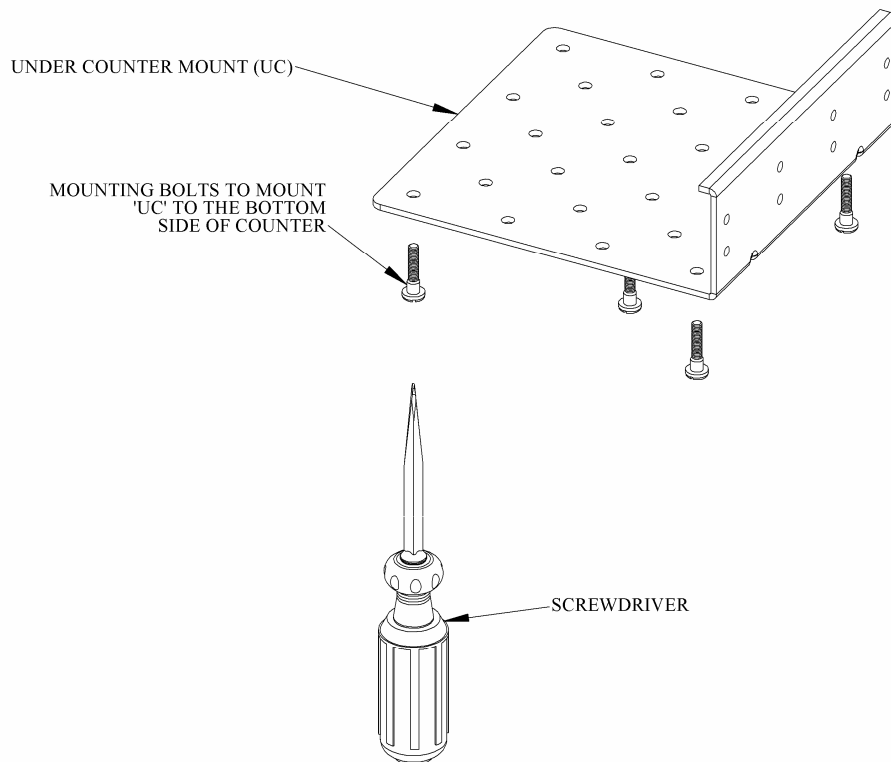

**Figure 4 – Under Counter Mounting Plate with Mounting Screws**

**UVHM-UC-R6-VESA: PN 80240**

A single position under counter mounting plate with one 6" riser, one 8" arm and a VESA tilt head

ITEM#	PART#	DESCRIPTION	QTY.
1	70003	BOLT, 5/16-18x1.75"LG HEX HD	1
2	70038	WASHER, .75"IDx.312"IDx.05"Thk	2
3	70011	END PLUG	2
4	70018	SPACER, Plastic, .50ODx.257IDx.375LG	1
5	70009	TRI TIP KNOB, 1/4-20 x .50 LG,	1
6	70019	SCREW, 1/4-20 x 1-3/4" L PHILLIPS PAN HD	2
7	70014	1/2" OD x 5/16" ID x 1-1/8" L	1
8	50165	UNDER COUNTER MOUNT PLATE	1
9	70035	SLEEVE, 1/2"ODx5/16"IDx1-1/2"L	1
10	70022	SILICONE WASHER	3
10	70036	WASHER, SILICONE	1
11	50156	RISER CAP TOP	1
12	70000	BOLT, PHILLIPS 1/4-20x.50"LG, RND	5
13	50162	UVHM 6" RISER ASSEMBLY	1
14	50046	UVHM STANDARD STANDOFF BRACKET	1
15	70061	BOLT, .313-18 x 2.25" LG	1
16	50030	VESA TILT HEAD	1
17	70023	4 POINT KNOB, 5/16-18x1.75"L	2
18	70020	SCREW, PHILLIPS, 10-32x1/4" Bttn Hd	2
19	50028	TILT HEAD BASE	1
20	50048	8" MOUNT ARM	1
21	70021	5 POINT STAR KNOB, 5/16-18x2.0"LG	1

For other UVHM-UC-R assemblies please refer to the UVHM-UC-R product manual cover page.

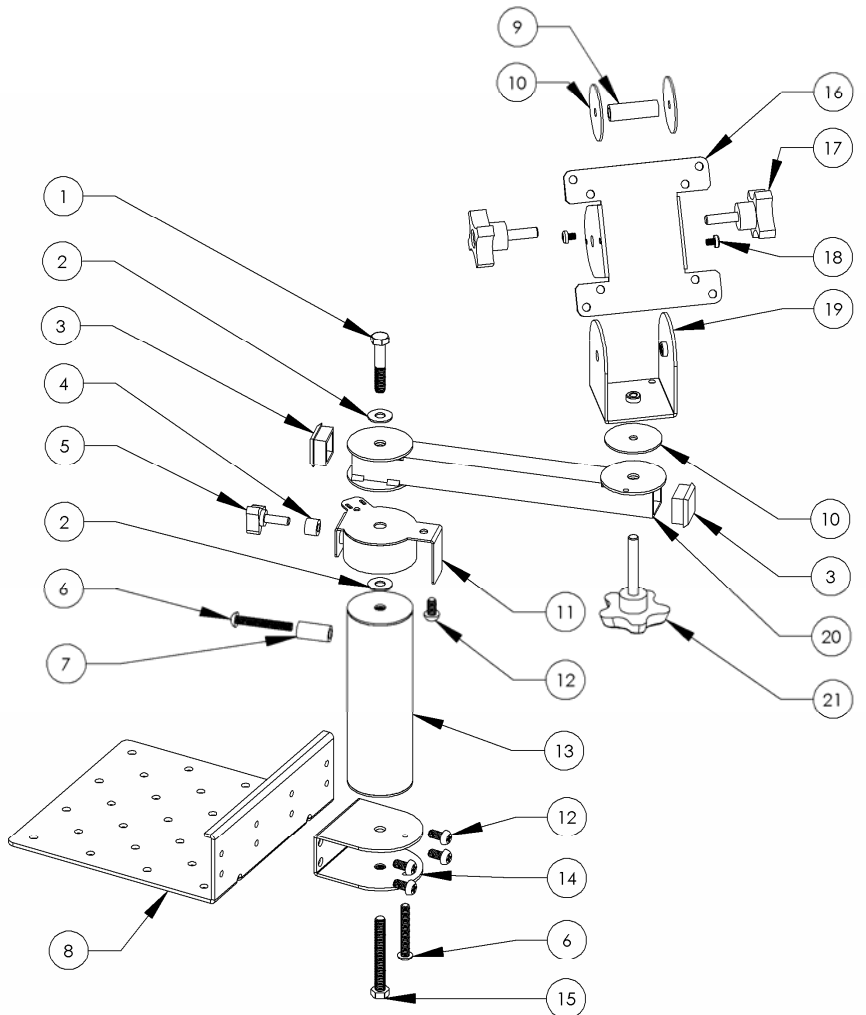

**Figure 5 - Under Counter Mount w/ 6" Riser, 8" Arm, and a Screen Pan and Tilt Head exploded parts view (PN 80240)**