

PQS

PRACTICAL QUALITY SYSTEMS
Fast Custom Manufacturing - Nationwide Installation Services

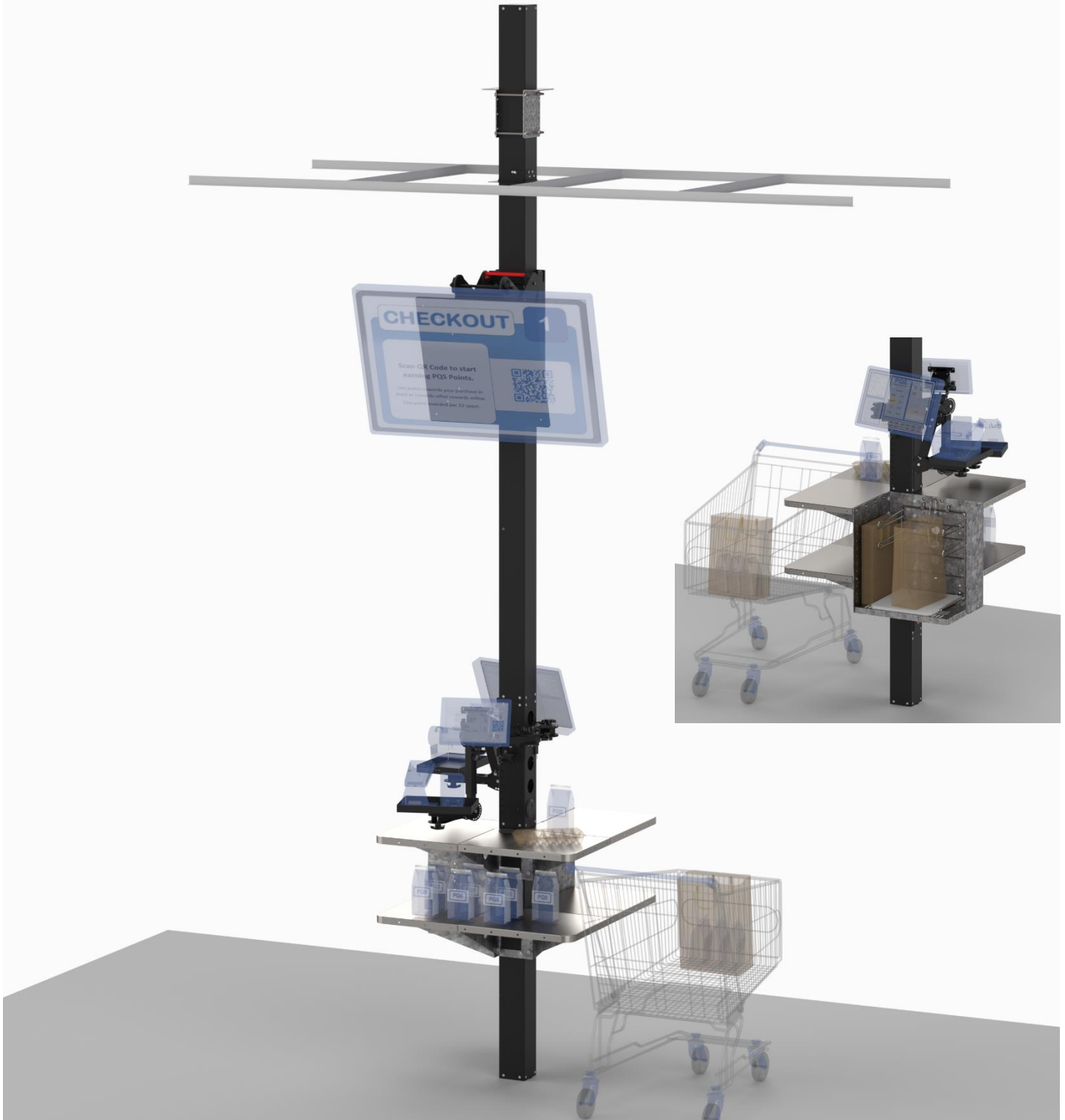

PN 81454 show, POS equipment and other misc. items not included

Page	Table of Contents Part 1
1	Cover page
2	Table of Contents Part 1
3	Table of Contents Part 2
4	Table of Contents Part 3 .
5	Overview of the 4X4 Pole System Product Groups
	Product Assembly Diagrams and Parts Lists
6	PN 81440
7	PN 81441
8	PN 81442
9	PN 81443
10	PN 81448
11	PN 81449
12	PN 81454
	Sub-assembly Diagrams and Information
13	PN 51064 Channel Extension Pass Through Mounting Bracket
14	PN 51065, 51066, 51067 Channel Extension Sections
15	PN 51062 Pedestal Channel and Channel Extension Coupler
16	Channel Extension Cover Plates and Power/Data Outlet Kits
17	PN 81588 30"W x 30"D Stainless Table Assembly + Cable grommet
18	PN 81589 30"W x 30"D Stainless Table Assembly with a Recessed Side Shelf and Bag Holder
19	PN 81590 30"W x 30"D Bi Level Stainless Table Assembly with Recessed Side Shelf and Bag Holder
20	PN 21266 18" Pedestal Channel Assembly
21	PN 21280 Arm Collar Assembly that supports up to four adjustable Arms
22	PN 21240 8" Straight Adjustable Arm Assembly with Standard 75-100mm VESA Pan and Tilt (part 1)
23	PN 21240 8" Straight Adjustable Arm Assembly with Standard 75-100mm VESA Pan and Tilt (part 2)
24	PN 21246 Fully Articulating Arm Assembly with POS Printer or Peripheral Equipment Tray
25	PN 21252 Fully Articulating Extendable Arm Assembly, POS Printer or Peripheral Equipment Tray
26	PN 21284 Pedestal Channel Cable Management Kit
27	PN 70444 2" Round 1 Power Receptacle + 2X USB-A Outlet 6.5 Ft. cord
28	PN 81561 Clamp On 100-400mm VESA Tilting Mount
29	PN 22004 Above Ceiling Mounting Plates Kit
30	PN 21262 4X4 Ceiling Trim Ring Kit
31	Assembly and Installation Instructions +Installation instructions Introduction
32	Calculating the vertical height of a 4x4 Pole Assembly that spans to the ceiling
33	Planning the installation of the equipment and associated wiring on a Pole Assembly that spans to the ceiling
34	Understanding the basic functions of the Pedestal Channel Assembly
35	Understanding the basic functions of the Arm Collar Assembly
36	Understanding the Basic Functions of Channel Extension Sections
37	Understanding Channel Extension Cover Plates

Page	Table of Contents Part 2
	Assembly and Installation Instructions Continued
38	Locating and installing a base mounting bracket
39	Permanently attaching the Feed Through mounting base bracket to the mounting surface
40	Pre-assembling a Pole Assembly and installing an internal coupler to connect two Channel Extension sections
41	Pre-assembling the Pole Assembly and installing an internal coupler to connect a Pedestal Channel Section to a Channel Extension section
42	Installing an Arm Collar Assembly onto a Pedestal Channel Section
43	Locating the Pole Assembly in a Suspended Tee Bar ceiling
44	Understanding how to attach the of the top of the pole assembly to the structure above the ceiling
45	Attaching the Above Ceiling Mounting Plates to the top of the Pole Assembly
46	Attaching the Above Ceiling Mounting Plates to the overhead ceiling structure
47	Attaching Junction boxes to the Above Ceiling Mounting Plates
48	Assembling and connecting the outlets on the cover plates
49	Using a PN 21208 NO J BOX Faceplate Adapter kit to attach Data, blank or other single gang faceplates to the cut-outs on channel extension section cover plates
50	Installing the associated conduits and cabling into the Pole Assembly
51	Installing Cover Plates on Channel Extension sections
52	Installing and routing the power and other associated cables through a Pedestal Channel and an Extension Section with Coupler
53	Installing the 4X4 Clamp On 100-400mm VESA Tilting Mount Clamping Assembly on a pole
54	Attaching a PN 81561 4X4 Clamp On 100-400mm VESA Tilting Mount to the back of a screen
55	Attaching a screen with a 100-400mm VESA Mounting Plate Assembly onto a Clamping Assembly on a pole. (Part 1)
56	Attaching a screen with a 100-400mm VESA Mounting Plate Assembly onto a Clamping Assembly on a pole. (Part 2)
57	Attaching a 4 section, 30" X 30" Table Shelf to a Pole Assembly (part 1)
58	Attaching a 4 section, 30" X 30" Table Shelf to a Pole Assembly (part 2)
59	Attaching a 4 section, 30" X 30" Table Shelf to a Pole Assembly (part 3)
60	Assembling a Single or Double 30" X 30" Table with a Recessed Side Shelf unit and Bag Holder (part 1)
61	Assembling a Single or Double 30" X 30" Table with a Recessed Side Shelf unit and Bag Holder (part 2)
62	Assembling a Single or Double 30" X 30" Table with a Recessed Side Shelf unit and Bag Holder (part 3)
63	Assembling a Single or Double 30" X 30" Table with a Recessed Side Shelf unit and Bag Holder (part 4)
64	Assembling a Single or Double 30" X 30" Table with a Recessed Side Shelf unit and Bag Holder (part 5)
65	Installing and adjusting Shelves on a 30X30 Recessed Side Shelf Unit
66	Installing the Ceiling Trim Ring
67	Installing and routing the power and other associated cables to a Pedestal Channel sections on a Channel Extension Section
68	Assembling the lower half of an Articulating Extendable arm on an arm collar assembly
69	Attaching a VESA Pan and Tilt Head to the Back of a Screen
70	Installing a screen with an attached VESA Pan and Tilt Head on the end of an Arm

Page	Table of Contents Part 3
	Assembly and Installation Instructions Continued
71	Attaching a POS Printer or Peripheral Equipment Tray to the end of an Arm
72	Introduction to the 4X4 Pole Systems Product Groups and links to Web Pages - Page 1
73	Introduction to the 4X4 Pole Systems Product Groups and links to Web Pages - Page 3
74	Introduction to the 4X4 Pole Systems Product Groups and links to Web Pages - Page 2
75	Introduction to the 4X4 Pole Systems Product Groups and links to Web Pages - Page 4
76	Bonus page

An Overview of the 4X4 Pole System Product Groups; Totally Modular, Totally Customizable!

Note; for images, descriptions and links to webpages for all of the various 4X4 Pole Systems Product Groups; review the last pages of this document.

- These product groups consist of modular, industrial grade, multi-arm pole or pedestal channel systems designed to support multiple VESA compatible touch computers, monitors, large screen displays and a wide range of peripheral devices with a variety of accessories such as stainless steel work tables, shelving systems, bag holders, integrated power and data outlets, and more.
- The 4" X 4" square channel assemblies aka "pole sections" and some of the sub-assemblies in this product group are made of heavy gauge, cold rolled steel and are finished with an ultra-durable, black, low gloss; micro wrinkle powder coating that resists chipping, scratching, fading, corrosion and staining. All other components are made of galvanized and stainless steel.
- Refer to the pages entitled "Introduction to the 4X4 Pole Systems Product Groups" for a list of the various types of preconfigured systems.
- All individual components are modular and interchangeable allowing a great variety of configuration options and ensuring the ability to easily reconfigure systems in the future. These systems are made for the most demanding environments.
- We've created many preconfigured product assemblies as examples of how the components can be used in various applications. However, if you have special requirements; know that we can quickly create a custom assembly by starting with a preconfigured assembly and then adding or removing individual system components as needed to render a perfect fit for your application.

What makes these systems different?

- No engineering degree required to understand how the individual components fit together.
- The modular design allows total system flexibility for simplified customization.
- Designing a system doesn't require hiring an architect.
- There's no lost time waiting for custom millwork or fixtures having to be made to fit your space.
- No need to cut and trench concrete floors; these systems can feed power and data down from the ceiling.
- You don't need to deal with multiple contractors; these systems can be installed by any competent electrician.
- The systems are modular and can easily be reconfigured if your needs change.
- There are NO molded plastic structural parts to break or wear out, no springs or pneumatic cylinders to fail and NO special tools required for position adjustment.
- Easy to access concealed internal storage and cable routing on all channel sections.
- The side to side and up and down positioning of support arms, VESA compatible pan and tilt heads, peripheral trays, etc. can be adjusted easily without tools.
- Add power or data outlets at any location along the entire length of channel extension sections.
- We also have vertical and horizontal 4X4 wireway -pole systems that are made entirely of stainless steel.

Need something special?

- Our in house design team offers fast turnaround on custom parts. If you wish to order a quantity of custom products, we will create a new assembly specifically pre-configured for your application.

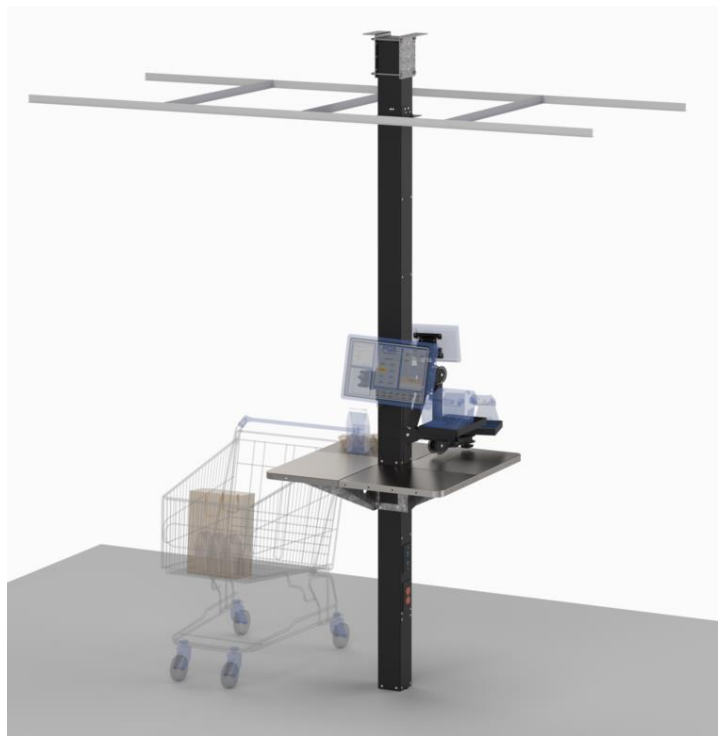

PN 81440 Cashier Pole Stand 102" H + 1 - 30"X30" SS Table+ 2-VESA+2 POS Tray+2-8" arm, 1-Full.Art. Arm, 1-Full.Art.Ext. Arm

PN	QTY	DESCRIPTION
21260	1	Direct Mount Channel Extension Base Mounting Bracket Kit
51065	1	36" Channel Extension Section
21266	1	18" Pedestal Channel Assembly
51066	1	48" Channel Extension Section
21271	2	Pedestal Channel And Extension Section Coupler Kit
81587	1	30"X 30" Stainless Table Shelf Assembly
21280	1	4X4 Pedestal Channel Collar Assembly for up to 4 arms
21252	1	Fully Articulating Extendable Arm + Printer Tray Assembly
21246	1	Fully Articulating Arm + Printer Tray Assembly
21240	2	8" Adjustable Arm + Standard VESA Pan and Tilt Head Assembly
21297	1	12" Channel Extension Cover Plate +2 Power and Data Outlets Kit
21295	1	24" Channel Extension Blank Cover Plate Kit
21293	1	48" Channel Extension Blank Cover Plate Kit
21262	1	PED3 Ceiling Trim Ring Black Kit
22004	1	Above Ceiling Mounting Plates Kit
21284	1	Pedestal Channel Cable Management Kit
70444	1	2" Round 1 Power receptacle + 2X USB-A Outlet 6 Ft. cord, Black
30092	1	3 Outlet Power strip 6 Ft. cord Black

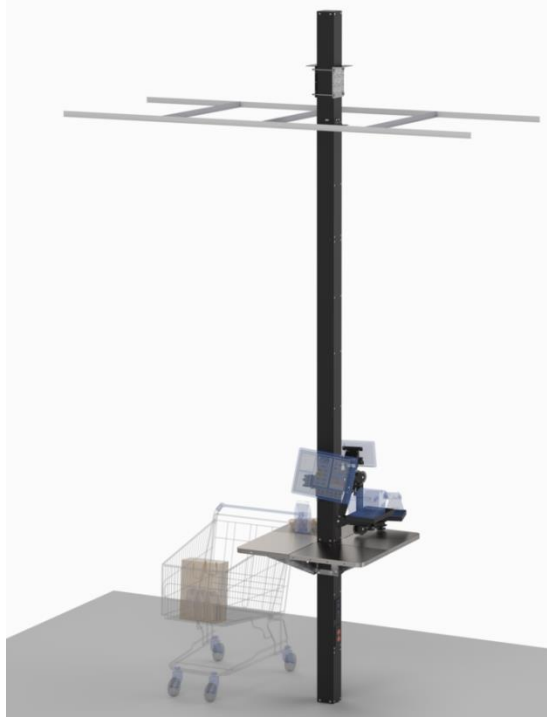

PN 81441 Cashier Pole Stand 150" H + 1 - 30"X30" SS Table+ 2-VESA+2 POS Tray+2-8"arm, 1-Full.Art. Arm, 1-Full.Art.Ext. Arm

PN	QTY	DESCRIPTION
21260	1	Direct Mount Channel Extension Base Mounting Bracket Kit
51065	1	36" Channel Extension Section
21266	1	18" Pedestal Channel Assembly
21269	1	96" Channel Extension Assembly
21271	2	Pedestal Channel And Extension Section Coupler Kit
81587	1	30"X 30" Stainless Table Shelf Assembly
21280	1	4X4 Pedestal Channel Collar Assembly for up to 4 arms
21252	1	Fully Articulating Extendable Arm + Printer Tray Assembly
21246	1	Fully Articulating Arm + Printer Tray Assembly
21240	2	8" Adjustable Arm + Standard VESA Pan and Tilt Head Assembly
21297	1	12" Channel Extension Cover Plate +2 Power and Data Outlets Kit
21295	1	24" Channel Extension Blank Cover Plate Kit
21293	2	48" Channel Extension Blank Cover Plate Kit
21262	1	PED3 Ceiling Trim Ring Black Kit
22004	1	Above Ceiling Mounting Plates Kit
21284	1	Pedestal Channel Cable Management Kit
70444	1	2" Round 1 Power receptacle + 2X USB-A Outlet 6 Ft. cord, Black
30092	1	3 Outlet Power strip 6 Ft. cord Black

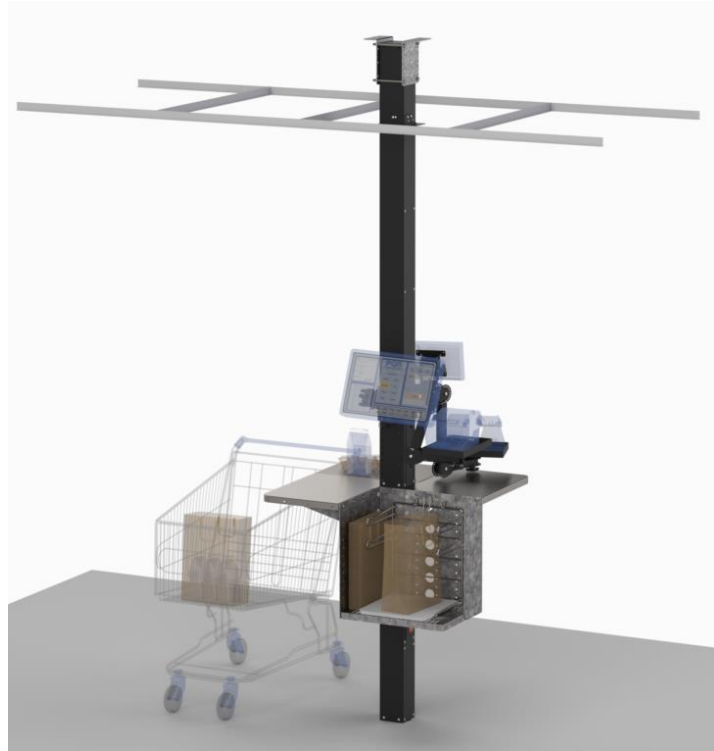

PN 81442 Cashier Pole Stand 102" H + 1 - 30"X30" SS Table+ 1 bag holder + 2-VESA+2 POS Tray+2-8"arm, 1-Full.Art. Arm, 1-Full.Art.Ext. Arm

PN	QTY	DESCRIPTION
21260	1	Direct Mount Channel Extension Base Mounting Bracket Kit
51065	1	36" Channel Extension Section
21266	1	18" Pedestal Channel Assembly
51066	1	48" Channel Extension Section
21271	2	Pedestal Channel And Extension Section Coupler Kit
81589	1	30"X 30" Stainless Table Shelf Assembly+ 1- Bag Holder
21280	1	4X4 Pedestal Channel Collar Assembly for up to 4 arms
21252	1	Fully Articulating Extendable Arm + Printer Tray Assembly
21246	1	Fully Articulating Arm + Printer Tray Assembly
21240	2	8" Adjustable Arm + Standard VESA Pan and Tilt Head Assembly
21297	1	12" Channel Extension Cover Plate +2 Power and Data Outlets Kit
21295	1	24" Channel Extension Blank Cover Plate Kit
21293	1	48" Channel Extension Blank Cover Plate Kit
21262	1	PED3 Ceiling Trim Ring Black Kit
22004	1	Above Ceiling Mounting Plates Kit
21284	1	Pedestal Channel Cable Management Kit
70444	1	2" Round 1 Power receptacle + 2X USB-A Outlet 6 Ft. cord, Black
30092	1	3 Outlet Power strip 6 Ft. cord Black

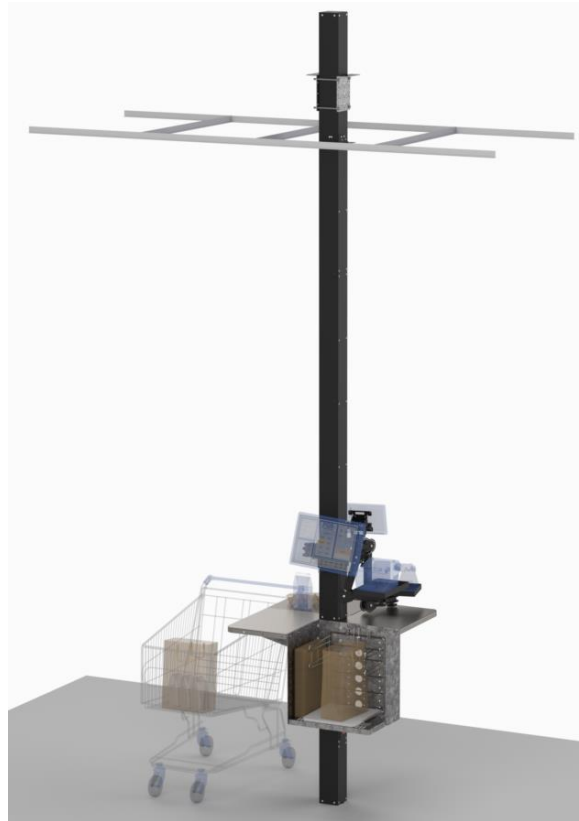

PN 81443 Cashier Pole Stand 150" H + 1 - 30"X30" SS Table+ 1 bag holder 2-VESA+2 POS Tray+2-8"arm, 1-Full.Art. Arm, 1-Full.Art.Ext. Arm

PN	QTY	DESCRIPTION
21260	1	Direct Mount Channel Extension Base Mounting Bracket Kit
51065	1	36" Channel Extension Section
21266	1	18" Pedestal Channel Assembly
21269	1	96" Channel Extension Assembly
21271	2	Pedestal Channel And Extension Section Coupler Kit
81589	1	30"X 30" Stainless Table Shelf Assembly+ 1- Bag Holder
21280	1	4X4 Pedestal Channel Collar Assembly for up to 4 arms
21252	1	Fully Articulating Extendable Arm + Printer Tray Assembly
21246	1	Fully Articulating Arm + Printer Tray Assembly
21240	2	8" Adjustable Arm + Standard VESA Pan and Tilt Head Assembly
21297	1	12" Channel Extension Cover Plate +2 Power and Data Outlets Kit
21295	1	24" Channel Extension Blank Cover Plate Kit
21293	2	48" Channel Extension Blank Cover Plate Kit
21262	1	PED3 Ceiling Trim Ring Black Kit
22004	1	Above Ceiling Mounting Plates Kit
21284	1	Pedestal Channel Cable Management Kit
70444	1	2" Round 1 Power receptacle + 2X USB-A Outlet 6 Ft. cord, Black
30092	1	3 Outlet Power strip 6 Ft. cord Black

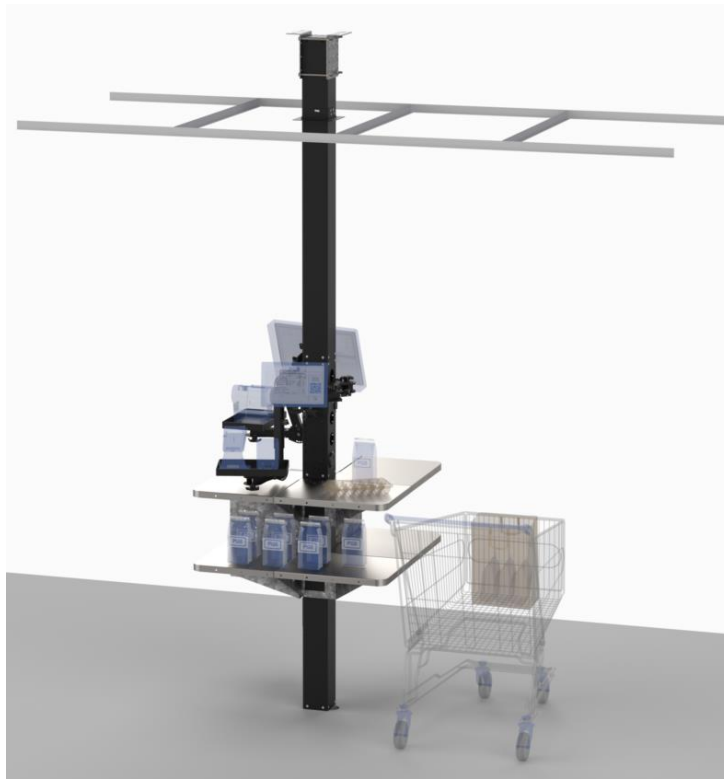

PN 81448 Cashier Pole Stand 102" H + 2 - 30"X30" SS Table+ 1 bag holder, 2-VESA+2 POS Tray+2-8"arm, 1-Full.Art. Arm, 1-Full.Art.Ext. Arm

PN	QTY	DESCRIPTION
21260	1	Direct Mount Channel Extension Base Mounting Bracket Kit
51065	1	36" Channel Extension Section
21266	1	18" Pedestal Channel Assembly
51066	1	48" Channel Extension Section
21260	2	Pedestal Channel And Extension Section Coupler Kit
81590	1	Double 30"X 30" Stainless Table Shelf Assembly+ 1- Bag Holder
21280	1	4X4 Pedestal Channel Collar Assembly for up to 4 arms
21252	1	Fully Articulating Extendable Arm + Printer Tray Assembly
21246	1	Fully Articulating Arm + Printer Tray Assembly
21240	2	8" Adjustable Arm + Standard VESA Pan and Tilt Head Assembly
21297	1	12" Channel Extension Cover Plate +2 Power and Data Outlets Kit
21295	1	24" Channel Extension Blank Cover Plate Kit
21293	1	48" Channel Extension Blank Cover Plate Kit
21262	1	PED3 Ceiling Trim Ring Black Kit
22004	1	Above Ceiling Mounting Plates Kit
21284	1	Pedestal Channel Cable Management Kit
70444	1	2" Round 1 Power receptacle + 2X USB-A Outlet 6 Ft. cord, Black
30092	1	3 Outlet Power strip 6 Ft. cord Black



PN 81449 Cashier Pole Stand 150" H + 2 - 30"X30" SS Table+ 1 bag holder 2-VESA+2 POS Tray+2-8"arm, 1-Full.Art. Arm, 1-Full.Art.Ext. Arm

PN	QTY	DESCRIPTION
21260	1	Direct Mount Channel Extension Base Mounting Bracket Kit
51065	1	36" Channel Extension Section
21266	1	18" Pedestal Channel Assembly
21269	1	96" Channel Extension Assembly
21260	2	Pedestal Channel And Extension Section Coupler Kit
81590	1	Double 30"X 30" Stainless Table Shelf Assembly+ 1- Bag Holder
21280	1	4X4 Pedestal Channel Collar Assembly for up to 4 arms
21252	1	Fully Articulating Extendable Arm + Printer Tray Assembly
21246	1	Fully Articulating Arm + Printer Tray Assembly
21240	2	8" Adjustable Arm + Standard VESA Pan and Tilt Head Assembly
21297	1	12" Channel Extension Cover Plate +2 Power and Data Outlets Kit
21295	1	24" Channel Extension Blank Cover Plate Kit
21293	2	48" Channel Extension Blank Cover Plate Kit
21262	1	PED3 Ceiling Trim Ring Black Kit
22004	1	Above Ceiling Mounting Plates Kit
21284	1	Pedestal Channel Cable Management Kit
70444	1	2" Round 1 Power receptacle + 2X USB-A Outlet 6 Ft. cord, Black
30092	1	3 Outlet Power strip 6 Ft. cord Black

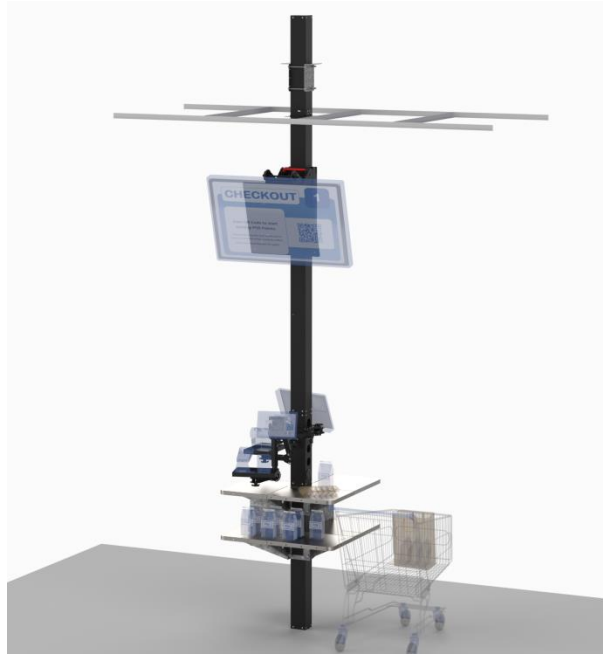

PN 81454 Cashier Pole Stand 150" H + 2 - 30"X30" SS Table+ 2-VESA+2 POS Tray+2-8"arm, 1-Full.Art. Arm, 1-Full.Art.Ext. Arm, 100-400mm VESA Clamp on Mount

PN	QTY	DESCRIPTION
21260	1	Direct Mount Channel Extension Base Mounting Bracket Kit
51065		36" Channel Extension Section
21266	1	18" Pedestal Channel Assembly
21269	1	96" Channel Extension Assembly
21260	2	Pedestal Channel And Extension Section Coupler Kit
81590	1	Double 30"X 30" Stainless Table Shelf Assembly+ 1- Bag Holder
21280	1	4X4 Pedestal Channel Collar Assembly for up to 4 arms
21252	1	Fully Articulating Extendable Arm + Printer Tray Assembly
21246	1	Fully Articulating Arm + Printer Tray Assembly
21240	2	8" Adjustable Arm + Standard VESA Pan and Tilt Head Assembly
21297	2	12" Channel Extension Cover Plate +2 Power and Data Outlets Kit
21299	1	12" Channel Extension Cover Plate Blank
21295	2	24" Channel Extension Blank Cover Plate Kit
21293	1	48" Channel Extension Blank Cover Plate Kit
21262	1	PED3 Ceiling Trim Ring Black Kit
22004	1	Above Ceiling Mounting Plates Kit
21284	1	Pedestal Channel Cable Management Kit
70444	1	2" Round 1 Power receptacle + 2X USB-A Outlet 6 Ft. cord, Black
30092	1	3 Outlet Power strip 6 Ft. cord Black
81561	1	4X4 100mm-400mm VESA Clamp on Mount Assembly

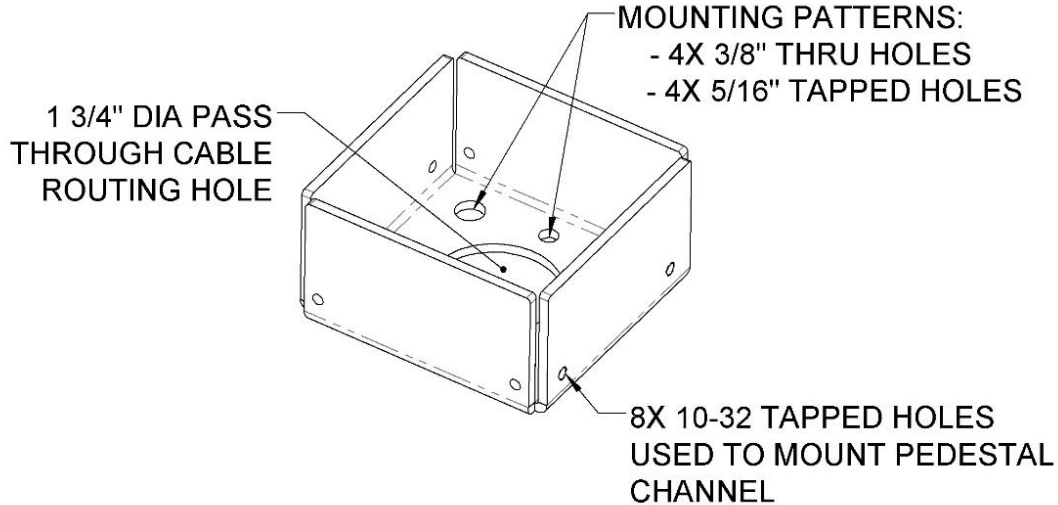

PN 51064 Channel Extension Pass Through Mounting Bracket

- This bracket attaches to a Channel Extension section and can be used to mount the channel to a Base Plate or directly to a floor, countertop or any other solid, horizontal surface.
- This bracket has a 1 3/4" diameter hole in the center to allow a number of conduits, armored cables or other cabling to be routed through as needed.
- This bracket is a heavy duty, internal structural member that is made of thick galvanized steel to resist corrosion.
- The mounting bracket includes arrays of through and tapped holes for attaching the bracket to the mounting surface.
- The mounting bracket attaches to a Channel Extension section with #10-32 X 1/2" L Countersunk Phillips Head Stainless steel screws.
- To understand the difference between the two types of channels; know that pedestal channels have a series of 6" tall doors installed on the "Open side" of the channel; while Channel Extension sections have Cover Plates installed on the on the "Open side" of the channel.

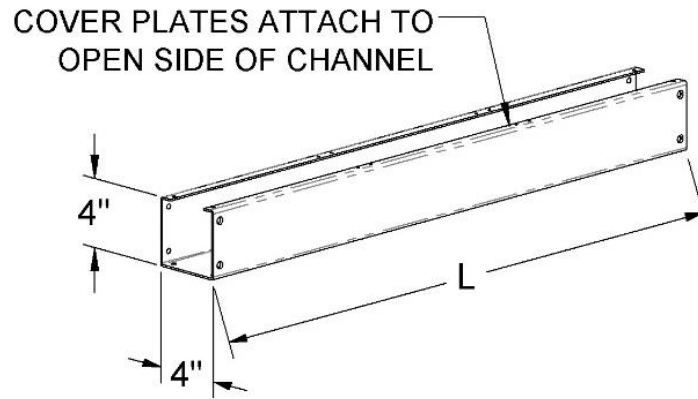
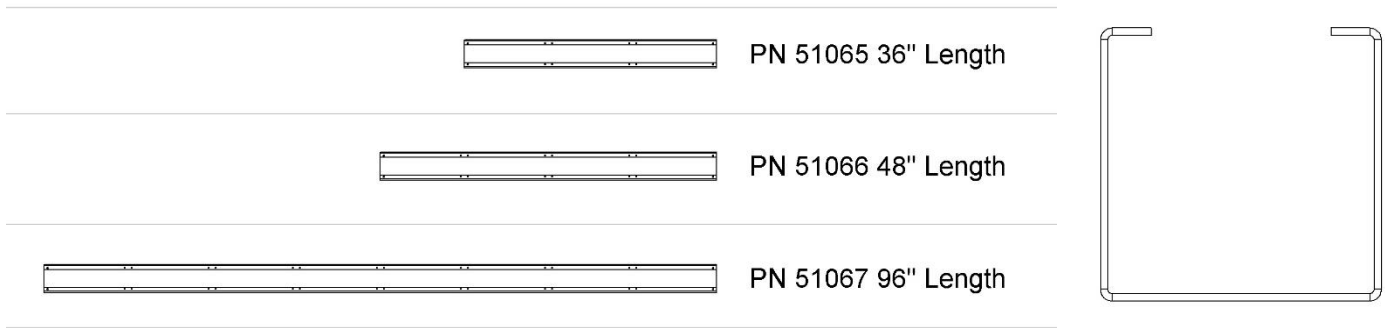



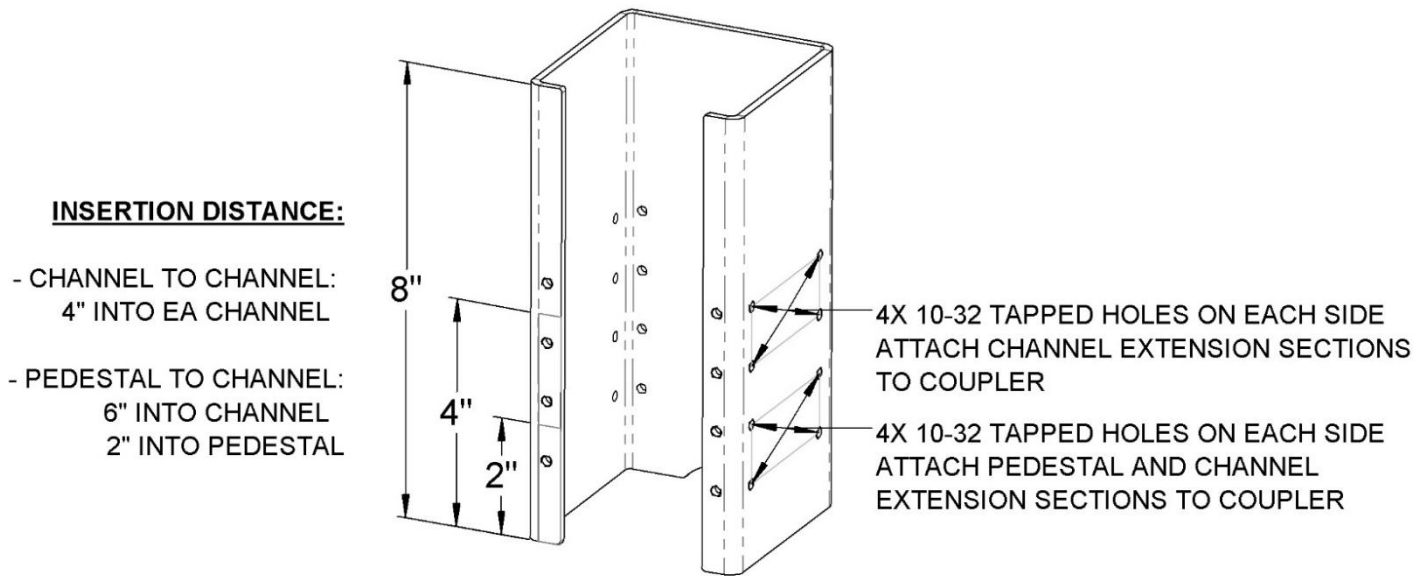

Channel Extension Sections: 36" PN 51065, 48" PN 51066, 96" PN 51067

- Channel Extension Sections are 4"x4" square, steel, "C shaped" channel assemblies with three solid sides and one "open" side.
- Channel Extension Sections are available in 36", 48", and 96" lengths.
- Channel extensions may be cut to size in-field for applications where necessary.
- The "Open side" of Channel extension section is closed with Cover Plates available in two basic types with multiple lengths:
Blank Cover Plates - available in 12", 24", 36", 48" lengths.
Cover Plates with Outlet Cut outs - available in 12" and 24" lengths.
- Any Channel Extension Section can be joined to another Channel Extension Section or to a Pedestal Channel Sections via an internal coupler.
- All Channel Extension Sections can be attached to Couplers, Base Mounting Brackets, and Cover Plates with #10-32 countersunk Phillips head screws.
- A wide variety of optional "4X4 Clamp on" mounting systems are available; a stainless steel table top or shelf, several types of VESA compatible screen mounts from 50mm to 400mm, POS Printer and Peripheral mounts, a single shelf unit for a cash drawer, a scale or a T-shirt bag holder and more. These versatile systems can be mounted at any point along the channel and easily adjusted. For more information see the Product Category: **"4X4 Clamp On Mounts"**.
- To understand the difference between the two types of channels; know that pedestal channels have a series of 6" tall doors installed on the "Open side" of the channel; while Channel Extension sections have Cover Plates installed on the on the "Open side" of the channel.

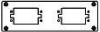

PN 51062 Pedestal Channel and Channel Extension Coupler

- This internal coupler allows a Pedestal Channel to be connected to a Channel Extension section and is also used to connect two Channel Extension sections together.
- The coupler is a heavy duty, 8 inch long, internal structural member that is made of thick galvanized steel that resists corrosion.
- When the coupler is used to join a Pedestal Channel to a Channel Extension section; the coupler is inserted 2 inches into the Pedestal Channel and 6 inches into the Channel Extension section.
- When the coupler is used to connect two Channel Extension sections together; the coupler is inserted 4 inches into the end of each Extension Section.
- (16) EA #10-32 X 1/2" L countersunk Phillips head screws are used to secure the coupler to Pedestal or extension sections.
- Install fasteners on three closed sides first, then install the fasteners on the open side.
- To understand the difference between the two types of channels; know that pedestal channels have a series of 6" tall doors installed on the "Open side" of the channel; while Channel Extension sections have Cover Plates installed on the on the "Open side" of the channel.
- Refer to section: **Pre-assembling the Pole Assembly and installing an internal coupler to connect two Channel Extension sections**

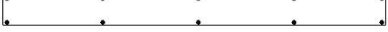
	PN 51075 - 12" BLANK
	PN 51075 - 12" 2 OUTLET
	PN 51071 - 24" BLANK
	PN 51071 - 24" 2 OUTLET
	PN 51070 - 36" BLANK
	PN 51069 - 48" BLANK

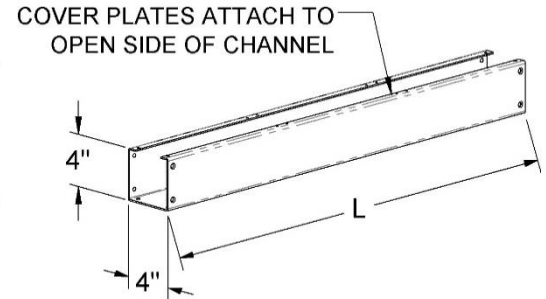

Channel Extension Cover Plates and Power/Data Outlet Kits

- Channel Extension Cover Plates are flat sheet metal panels used to cover the open side of Channel Extension sections. Cover Plates are available in two basic types and varying lengths; Blank plates and Plates with single-gang outlet cut-outs.
- Power Outlet kits include a 2 ½"D Single gang junction box equipped with a duplex receptacle and faceplate to create a power outlet. Note; deeper junction boxes and other types of receptacles can also be used.
- Data Outlet kits include a "NO J BOX" mounting kit, a 2 port Keystone faceplate and 2 EA CAT5e keystone data jacks. Note; a Single gang junction box can also be added if required.
- The locations of the power and data outlets are interchangeable on the outlet cutouts of the Cover Plate.
- Refer to the sections:

Installing Cover Plates on Channel Extension sections.

Assembling and connecting the outlets on the cover plates.

Using a PN 21208 NO J BOX Faceplate Adapter kit to attach Data, blank or other single gang faceplates to the cut-outs on channel extension section cover plates.

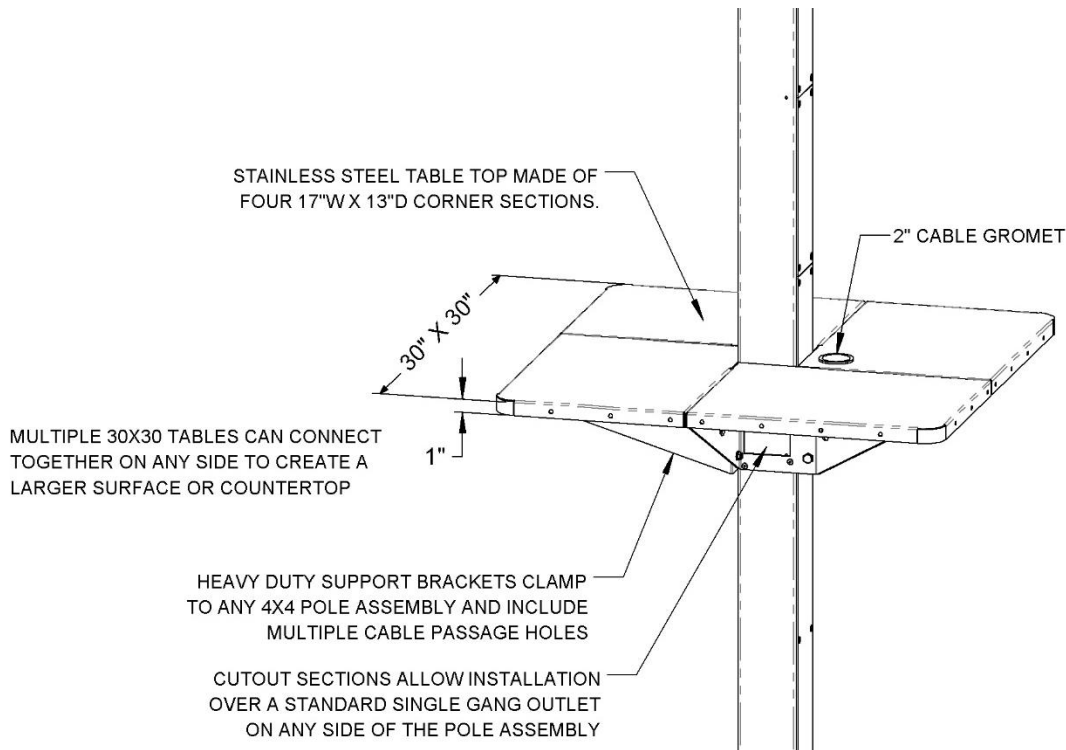

PN 81588 30"W x 30"D Stainless Table Assembly + Cable grommet

- The table top assembly measures 30" W X 30" D with a square opening in the center that allows any 4x4 pole assembly to pass through the table top so that they can be attached at any point along any vertical 4"W X 4"D square pole assembly.
- The table top is made up of four separate 17"W X 13"D corner sections that are joined together on the underside to create a 30 inch square stainless steel table top with four, smooth, rounded corners.
- Each of the table top corner sections is supported by a heavy duty, galvanized bracket that attaches to the underside of the table top and clamp directly to all four sides of any 4x4 pole assembly.
- One of the table corner sections has a 2" diameter hole with a grommet to allow cables to pass through.
- Multiple tables can be installed one above the other to create a sturdy, self-supporting shelving system with a minimum spacing of approximately 8 inches between the tops of any two 30"W X 30"D tables.
- The table support brackets include cut out sections to allow them to be installed over a standard single gang outlet located on any side of any 4X4 pole assembly, the brackets also include multiple holes for routing cables below the table top.
- The edges of two or more 30"W x 30"D Stainless Table Assemblies can be bolted together side to side to create larger table surfaces or countertops.
- If a four piece modular table top is not required; a one piece table top is also available.
- An optional Recessed Side Shelf Unit can be installed in place of any one of the four table 17"W X 13" D table top corner sections. Recessed Side Shelf units are available with Tee Shirt Bag holders or with one or more 17"W X 13"D shelves to support a mini cash drawer or other peripheral items.
- Refer to the section: Attaching a 4 section, 30" X 30" Table Shelf to a Pole Assembly (part 1 and 2)

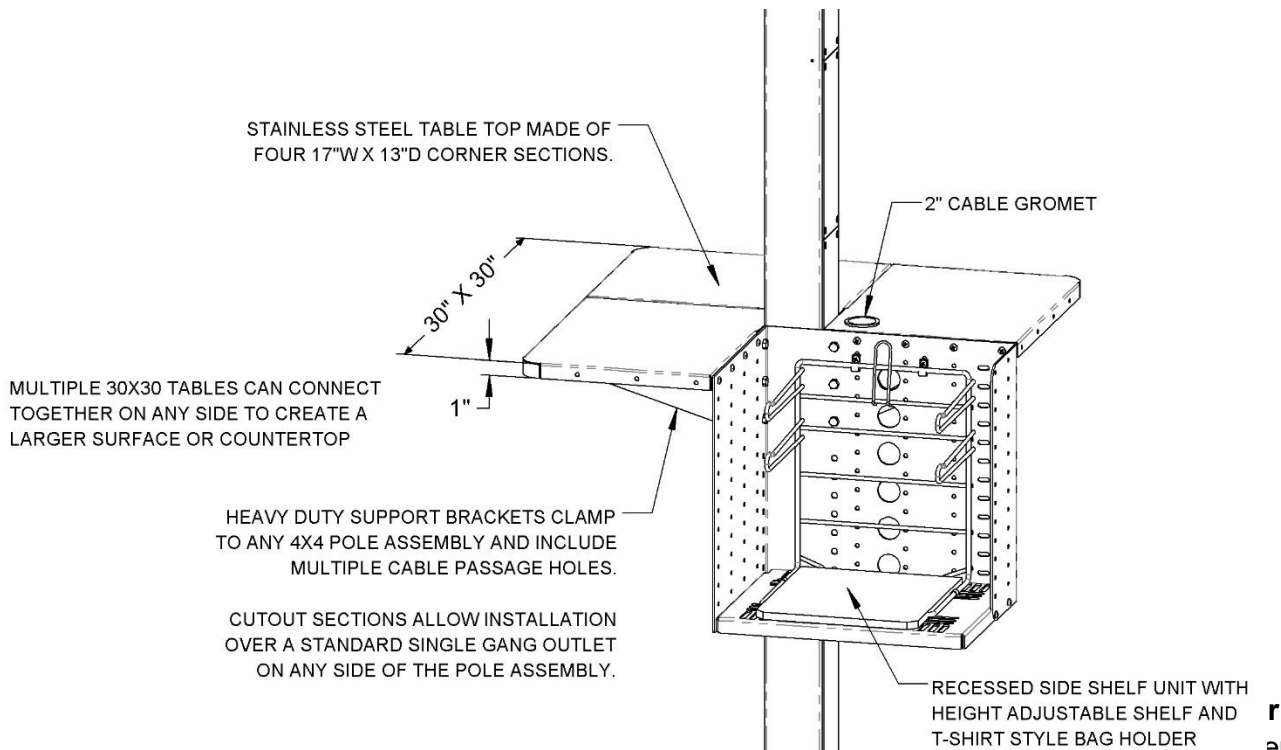
**F**

- The combined table top and the side shelf assemblies measure 30" W X 30" D with a square opening in the center that allows any 4x4 pole assembly to pass through the table top so that they can be attached at any point along any vertical 4"W X 4"D square pole assembly.
- The table top is made up of three separate 17"W X 13"D corner sections that along with a Recessed Side Shelf Assembly that are joined together on the underside to create a 30 inch "L" shaped stainless steel table top with three smooth, rounded outer corners.
- One of the table corner sections has a 2" diameter hole with a grommet to allow cables to pass through.
- Each table corner section is supported by a heavy duty, galvanized bracket which along with the Recessed Side Shelf frame clamp directly to all four sides of the pole assembly to create a very stable structure.
- The three table support brackets include cut out sections to allow them to be installed over a standard single gang outlet located on any side of any 4X4 pole assembly, the brackets also include multiple holes for routing cables below the table top.
- The T Shirt Bag Holder overall dimensions are 12" Wide x 12" Deep x 16" High. The bag holder stand is made of chromed steel rod with a 1/2" thick White PVC Plastic Sheet Base. Fits a standard; 11 1/2" Wide x 6" Deep x 21" High Bag. Holds medium-sized bags open for easy filling and can accommodate a large supply of bags. Smaller bags can fit on side hooks. Bags sold separately.
- This assembly is also available without a Tee shirt bag holder and can be configured as a Recessed Side Shelf Unit with one or more 17"W X 13"D shelves.
- The edges of two or more 30"W x 30"D Stainless Table Assemblies can be bolted together side to side to create larger table surfaces or countertops.
- Refer to the section: Assembling a Single or Double 30" X 30" Table with a Recessed Side Shelf unit and Bag Holder (part 1 and 2)
- Also available with optional stainless steel 17"W X 13"D table top section to cover top of the side shelf unit and create a complete, square 30"W x 30" D table top. Note that a cash drawer can be supported directly below the table top when shelf is installed in the Side Shelf unit just below the table top.

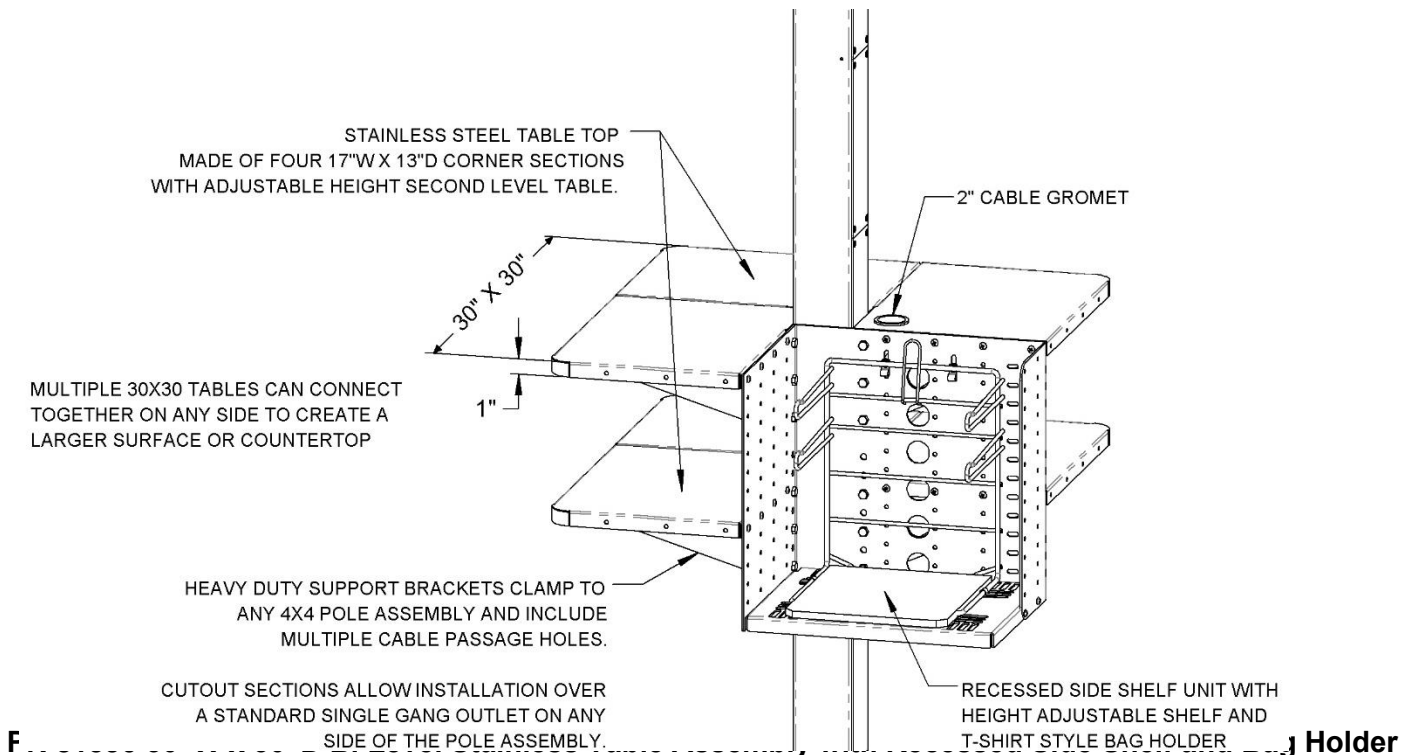

- The combined table tops and the side shelf assemblies measures 30" W X 30" D with a square opening in the center that allows any 4x4 pole assembly to pass through the table top so that they can be attached at any point along any vertical 4"W X 4"D square pole assembly.
- The table tops are made up of three separate 17"W X 13"D corner sections that along with a Recessed Side Shelf Assembly that are joined together on the underside to create a 30 inch "L" shaped stainless steel table top with three smooth, rounded outer corners.
- One of the table corner sections has a 2" diameter hole with a grommet to allow cables to pass through.
- Each table corner section is supported by a heavy duty galvanized bracket which along with the Recessed Side Shelf frame clamp directly to all four sides of the pole assembly to create a very stable structure.
- The three table support brackets include cut out sections to allow them to be installed over a standard single gang outlet located on any side of any 4X4 pole assembly, the brackets also include multiple holes for routing cables below the table top.
- An optional T Shirt Bag Holder or additional shelves can be added to the Recessed Side Shelf Assembly.
- The T Shirt Bag Holder overall dimensions are 12" Wide x 12" Deep x 16" High. The bag holder stand is made of chromed steel rod with a 1/2" thick White PVC Plastic Sheet Base. Fits a standard; 11 1/2" Wide x 6" Deep x 21" High Bag. Holds medium-sized bags open for easy filling and can accommodate a large supply of bags. Smaller bags can fit on side hooks. Bags sold separately.
- This assembly is also available without a Tee shirt bag holder and can be configured as a Recessed Side Shelf Unit with one or more 17"W X 13"D shelves.
- The edges of two or more 30"W x 30"D Stainless Table Assemblies can be bolted together side to side to create larger table surfaces or countertops.
- Refer to the section: Assembling a Single or Double 30" X 30" Table with a Recessed Side Shelf unit and Bag Holder (part 1 and 2)
- Also available with optional stainless steel 17"W X 13"D table top section to cover top of the side shelf unit and create a complete, square 30"W x 30" D table top. Note that a cash drawer can be supported directly below the table top when shelf is installed in the Side Shelf unit just below the table top.

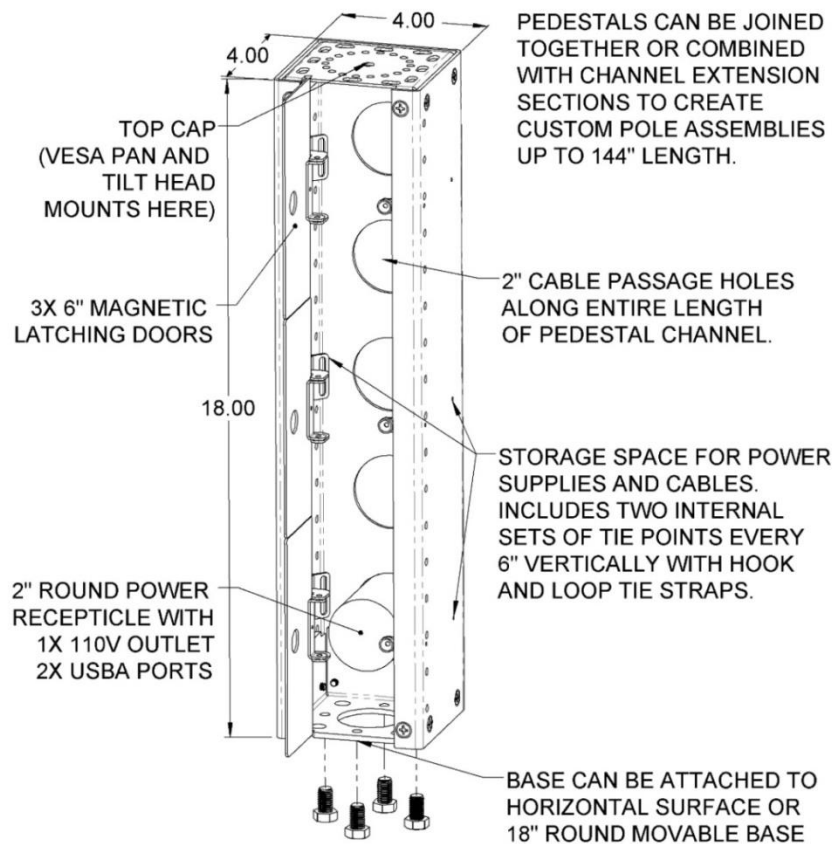

PN 21266 18" Pedestal Channel Assembly

- The 18" Pedestal Channel Assembly is a 4"W x 4"D square, three sided, channel that includes a top cap, a base mounting bracket and three 6" tall doors with magnetic latches attached to the open side of the channel.
- Allows internal storage space for power supplies and all associated cables.
- Interior includes two sets of cable tie points with hook and loop straps located every 6".
- Includes an array of 2" diameter cable passage holes along the entire length of one side of the channel.
- Includes a 2" round, corded power receptacle with a single 110V power outlet and two USB-A changing ports installed just above the pedestal base.
- Multiple 2 or 4 Arm Collar assemblies can be installed onto a Pedestal Channel.
- An Extended VESA Pan and Tilt Head can be attached to the top cap, but other items such as signage or a peripheral tray may also be installed.
- The 18" Pedestal Channel Section can be attached to an 18" Round Movable Base or can be attached directly to a countertop or to the top of a fixed or a mobile podium aka cabinet assembly.
- The mounting bracket has a 1 3/4" diameter round opening in the center to allow a number of conduits, armored cables or other cabling to be passed through as needed.
- Pedestal sections can also be combined with Channel Extension Sections to create 36" or 54" tall movable floor stands or fixed, vertical pole assemblies up to 144" tall.
- To understand the difference between the two types of channels; know that pedestal channels have a series of 6" tall doors installed on the "Open side" of the channel; while Channel Extension sections have Cover Plates installed on the on the "Open side" of the channel.

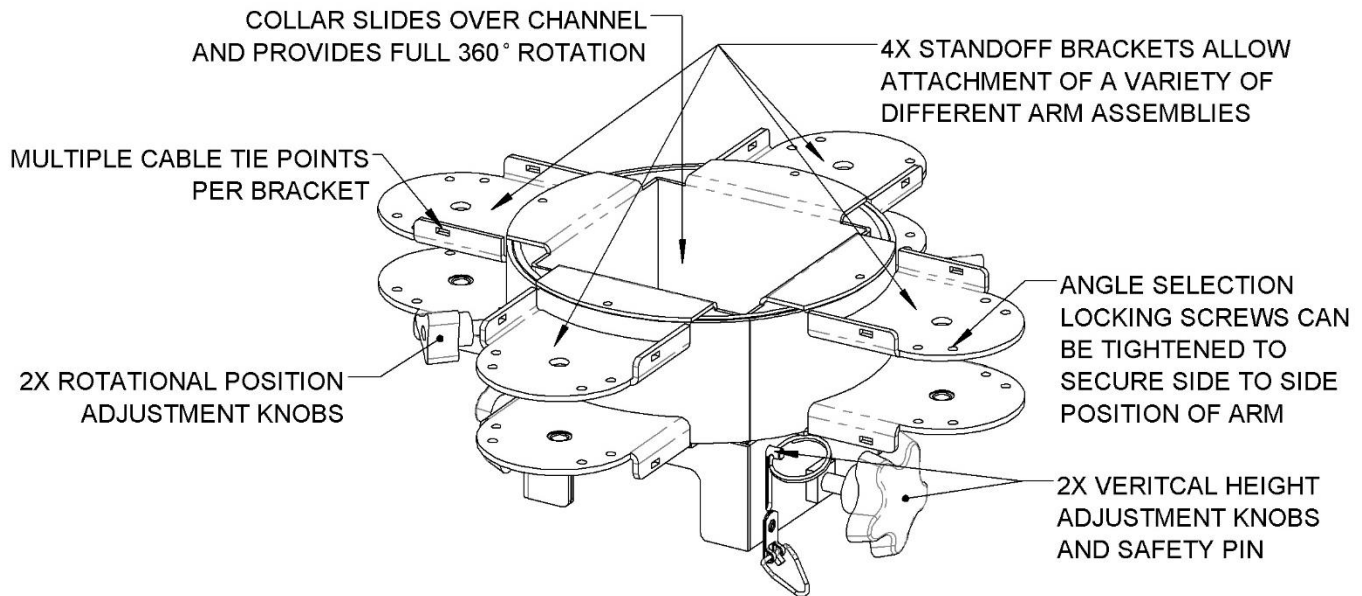

PN 21280 Arm Collar Assembly that supports up to four adjustable Arms

- The innovative 4 Arm Collar Assembly is the heart of the 4X4 multi-arm system and can support attachment of up to four independently adjustable Arm Assemblies in any combination of four available configurations: straight arms at 8" and 10" lengths, fully articulating arms, and fully articulating extendable arms. (See individual Arm Assembly descriptions for more details.)
- The Arm Collar Assembly adjusts without tools and can be positioned at any vertical location along the entire length of a Pedestal Assembly and can be rotated 360 degrees around the Pedestal Channel.
- Two 5-point hand knobs adjust the vertical position of the Arm Collar on the Pedestal Channel and a safety pin secures the assembly from accidental movement.
- Two 3-point hand knobs adjust the rotational position of the Arm Collar around the Pedestal Channel.
- All Arm Collar Stand Off Brackets include multiple cable tie points.
- Also available to support two Adjustable Arms PN 21279

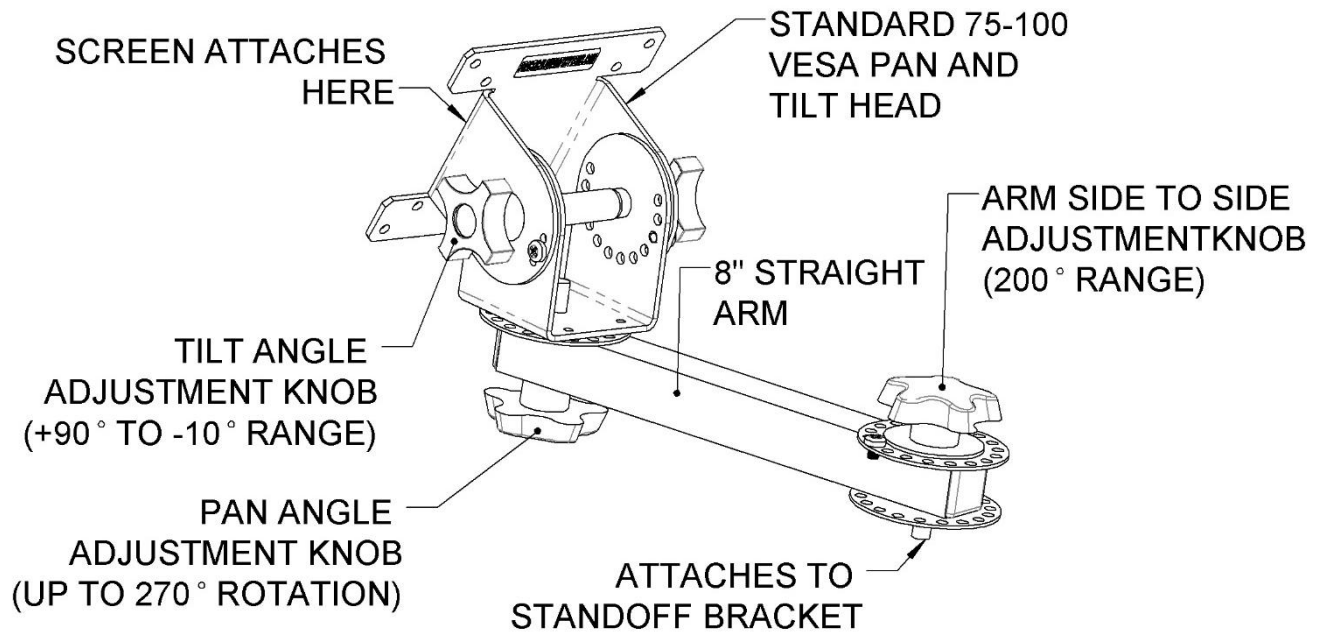

PN 21240 (part 1) 8" Straight Adjustable Arm Assembly with Standard 75-100mm VESA Pan- Tilt Head

- The 8" straight adjustable arm can be attached to any of the four standoff brackets on the Arm Collar assembly or to a 4X4 Clamp on mount.
- These arms have 200 degrees of side to side, horizontal position adjustment on the standoff brackets of the arm Collar Assembly.
- The horizontal, side to side position of the arm is adjusted with a 5 point hand knob on the upper standoff bracket. The knob works with a pair of rubber washers that are used in the assembly to provide a variable clutching resistance.
- A Phillips head screws that is also located on the upper standoff bracket can be tightened to permanently lock the side to side position of the arm.
- Refer to the section: **Installing a screen with an attached VESA Pan and Tilt Head on the end of an Arm.**

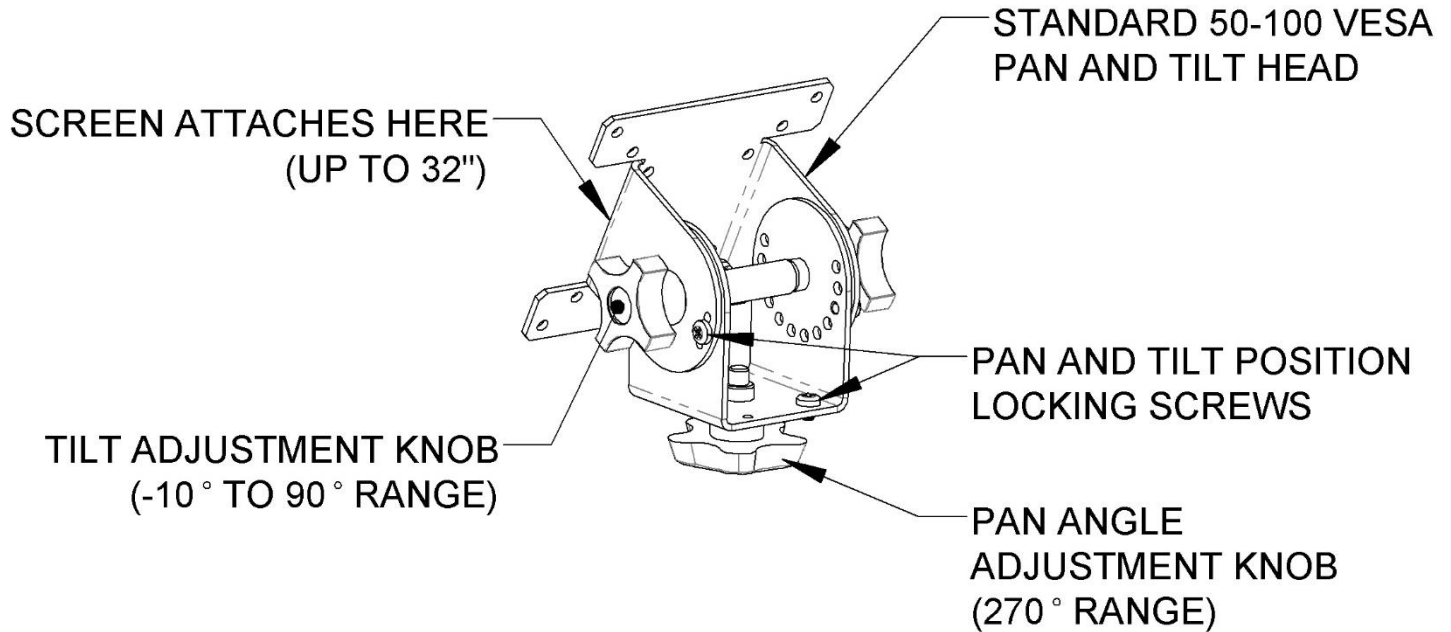

PN 21240 (part 2) 8" Straight Adjustable Arm Assembly with Standard 75-100mm VESA Pan- Tilt Head

- The Standard 50, 75,100mm VESA Pan and Tilt Head Assembly supports most screens up to 32" class and attaches to the end of any arm assembly without tools.
- Screen up and down tilt position can be adjusted from +90° to -10° and secured using two 4-point hand knobs.
- Screen side-to-side pan position can be adjusted up to 270°, dependent on screen size, and secured using a 5-point hand knob.
- The knobs work with rubber washers in the pan and tilt head assembly to provide variable clutching resistance.
- Screws located on the Pan Base and Tilt Bracket can be tightened to permanently secure the screen up and down tilt and side-to-side pan positions.
- Includes a 4EA M4X 10mm long VESA screws.
- Includes a cable tie point at the rear of the VESA mounting plate.
- All arm collar assemblies and all 4X4 Clamp on mounts will require that the VESA pan and tilt heads be attached to the ends of the arms.
- Refer to the section: "**Attaching a VESA Pan and Tilt Head to the Back of a Screen.**"

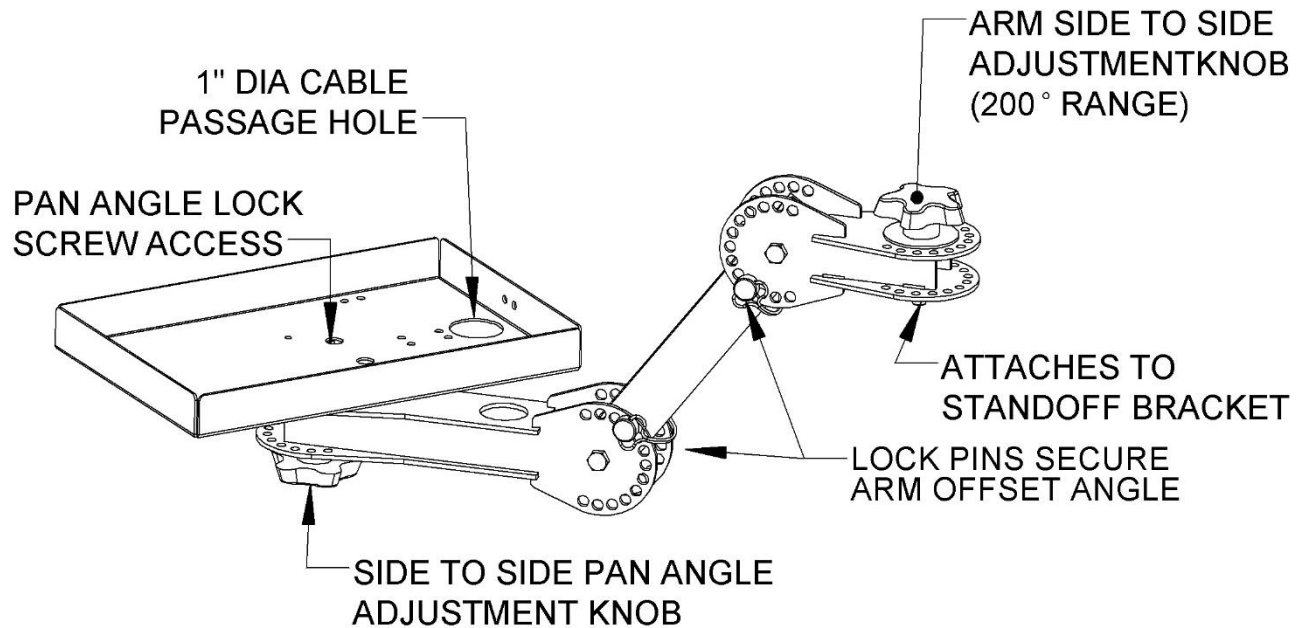

PN 21246 Fully Articulating Arm Assembly with POS Printer or Peripheral Equipment Tray

- The Fully Articulating Arm includes three arm segments and can be attached to any of the four standoff brackets on the Arm Collar assembly.
- This arm has 200 degrees of side to side, horizontal position adjustment on the standoff bracket of the arm Collar Assembly.
- The horizontal, side to side position of the arm is adjusted with a 5 point hand knob on the upper standoff bracket. The knob works with a pair of rubber washers that are used in the assembly to provide a variable clutching resistance.
- A Phillips head screw that is also located on the upper standoff bracket can be tightened to permanently lock the side to side position of the arm.
- The angles of upper and lower arm segments or "offset brackets" adjust to allow the middle arm section to be extended down and outward a selectable distance out from the channel assembly.
- Each of the offset brackets has 13 different adjustable positions in 18 degree increments using lynch pins with spring clip retainers.
- The 6½" W X 10¼" L X 1" D tray assembly supports a POS printer or one or more EMV and QR/ Barcode readers or other small equipment.
- The tray can be attached to the end of any of the four arm assemblies and can be rotated 360 degrees.
- The side to side pan position of the tray is adjusted with a 5 point hand knob located under the end of the last arm segment. The knob works with a rubber washer that is used in the assembly to provide a variable clutching resistance.
- A Philips head screws located on the pan plane in the middle of the tray can be tightened to permanently lock the side to side position of the Tray arm on the end of the arm.
- The tray includes a 1" diameter cable path hole and multiple pairs of small holes to feed cable ties through.
- Some assemblies may be shipped with the printer tray removed from the end of the arm; refer to section: **Attaching a POS Printer or Peripheral Equipment Tray to the end of an Arm.**

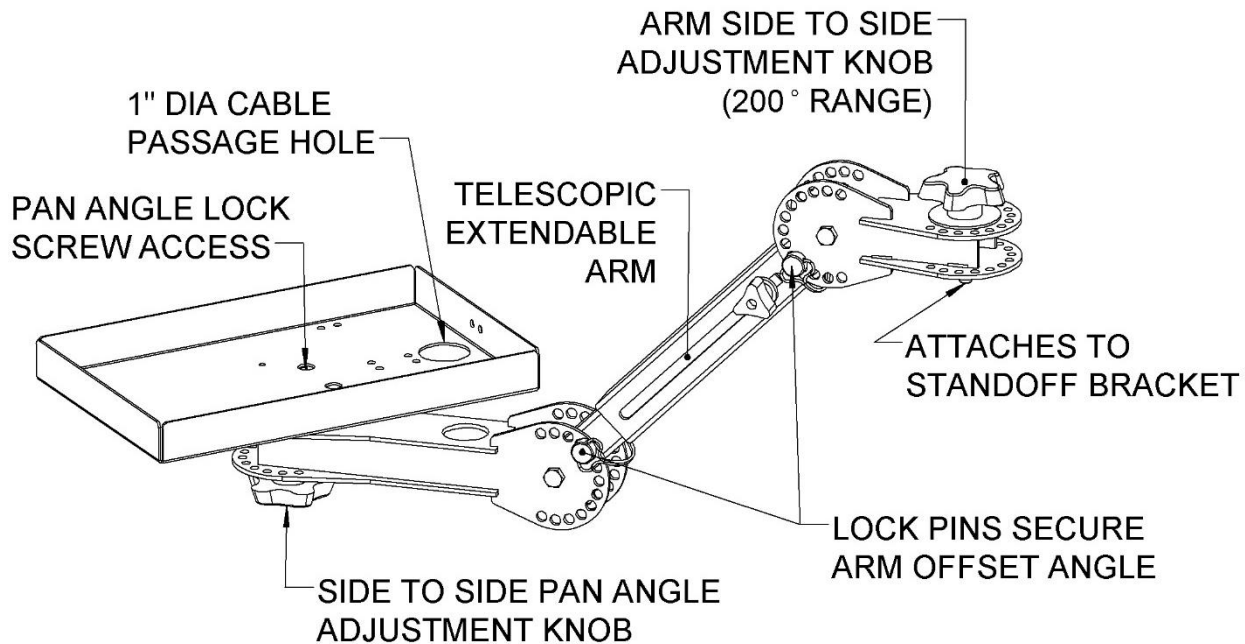

PN 21252 Fully Articulating Extendable Arm Assembly with POS Printer or Peripheral Equipment Tray

- The Fully Articulating Extendable Arm includes three arm segments and can be attached to any of the four standoff brackets on the Arm Collar assembly.
- This arm has 200 degrees of side to side, horizontal position adjustment on the standoff bracket of the arm Collar Assembly.
- The horizontal, side to side position of the arm is adjusted with a 5 point hand knob on the upper standoff bracket. The knob works with a pair of rubber washers that are used in the assembly to provide a variable clutching resistance.
- A Phillips head screw that is also located on the upper standoff bracket can be tightened to permanently lock the side to side position of the arm.
- The angles of upper and lower arm segments or “offset brackets” adjust to allow the middle arm segment to be extended down and outward a selectable distance out from the channel assembly.
- Each of the offset brackets has 13 different adjustable positions in 18 degree increments using lynch pins with spring clip retainers.
- The middle arm segment of this arm is telescopic and can be extended outward up to 6 inches. The extended position of the arm is adjusted with a 3 point knob on the side of the arm.
- The 6½” W X 10¼”L X 1” D tray assembly supports a POS printer or one or more EMV and QR/ Barcode readers or other small equipment.
- The tray can be attached to the end of any of the four arm assemblies and can be rotated 360 degrees.
- The side to side pan position of the tray is adjusted with a 5 point hand knob located under the end of the last arm segment. The knob works with a rubber washer that is used in the assembly to provide a variable clutching resistance.
- A Philips head screws located on the pan plane in the middle of the tray can be tightened to permanently lock the side to side position of the Tray arm on the end of the arm.
- The tray includes a 1” diameter cable path hole and multiple pairs of small holes to feed cable ties through.
- Some assemblies may be shipped with the printer tray removed from the end of the arm; refer to section: **Attaching a POS Printer or Peripheral Equipment Tray to the end of an Arm.**



21284 Pedestal Channel Cable Management Kit		
PN	QTY	DESCRIPTION
70450	1	Spiral Wrap 2ft L section black
70451	12	Cable tie 8" Black
70452	1	Hook and loop Strap, double sided 3/4" W X 8 ft. L Black

[info](#)

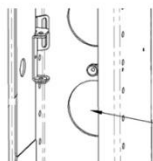

2" CABLE PASSAGE HOLES
ALONG ENTIRE LENGTH



PN 70444 2" Round 1 Power Receptacle + 2X USB-A Outlet 6.5 Ft. cord

- Most assemblies that include an 18" or 36" H Pedestal channel will include the 2" round power receptacle unit with a single 125V power outlet and two USB-A charging ports.
- The single high voltage power receptacle is rated a 125V volts at 12 amps, maximum output: 1500W.
- The two USB – A Outlets are rated at 5 volts at 2 amps; note the USB outlets are chargers only; they do not pass data.
- The power cord is 6.5 foot long with a standard grounded, three prong grounded plug.
- The outlet housing is made of black ABS plastic.
- Conforms to UL STD962A and is certified to CSA STD C 22.2 NO.309, for indoor use only.
- As shipped; the power outlet may be installed at the lowest 2" round cable passage hole.
- The location of the power outlet can be easily changed :
 1. Unplug the end of the power outlet cord.
 2. Loosen the power outlet retaining ring on the inside of the channel by holding the front bezel flange section while unscrewing the retaining ring in a counter clockwise direction from the rear of the outlet housing.
 3. Remove the retaining ring from the power cord, then guide the entire power outlet and power cord out from the cable passage hole.
 4. Pass the power cord through the new desired cable passage hole and then guide the power outlet housing into the cable passage hole.
 5. Orient the flat flange side of the retaining ring towards the inside wall of the pedestal channel, pass the power cord through from the power cord retaining ring.
 6. Slide the retaining ring up to the rear of the power outlet housing, hold the outer bezel section so that the outlet housing cannot turn; then carefully thread the retaining ring onto the rear of the outlet housing. When the retaining ring contacts the inside wall of the channel; only tighten it enough so that the housing does not turn easily.

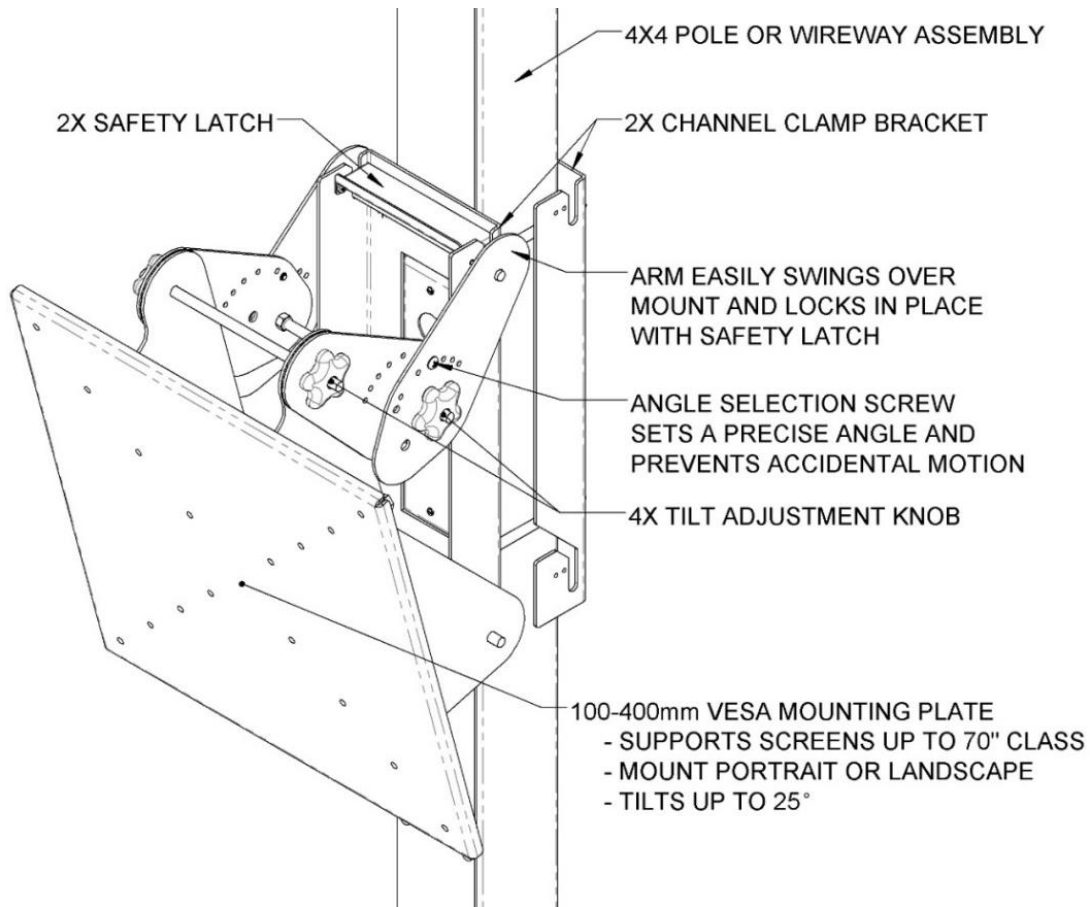
**PN 81561****Clamp****On 100-400mm VESA Tilting Mount**

- The 100-400mm VESA Clamp on mount allows screens up to 70" class to be mounted in either portrait or landscape orientation and tilted forward up to 25 degrees.
- Includes VESA mounting patterns for 100mm, 200mm, 300mm, 400mm or any height and width combination of these mounting standards.
- The Tilt Mount securely clamps to any 4"x4" vertical Pole or Wireway Assembly.
- The screen tilt position is adjustable from 0 degrees flat to 25 degrees forward and is secured with four 5-point hand knobs located behind the back of the screen, allowing easy adjustment without tools.
- Two Phillips head screws on the inner ends of the tilt link plates can be tightened into angle selection holes to more permanently lock the tilt position in increments of 5 degrees.
- Both of the channel clamping sections include cut out areas that allow the mount to be installed over two standard single gang outlets.
- Dual safety latches secure the tilt assembly to the channel clamp.
- Both of the channel clamping sections include through holes to allow self-drilling screws to be installed into the pole for a more permanent method of securing the mount.
- The clamping channel sections include a cut out section that allows two single gang power and /or data outlets to be installed behind the screen.
- Also available in a double configuration (PN 81562) with two screens oriented "back to back" on opposite sides of the pole assembly.
- For installation instructions, refer to the sections:

Attaching a PN 81561 4X4 Clamp On 100-400mm VESA Tilting Mount to the back of a screen.

Installing the 4X4 Clamp On 100-400mm VESA Tilting Mount Clamping Assembly on a pole.

Attaching a screen with a 100-400mm VESA Mounting Plate Assembly onto a Clamping Assembly on a pole. (Parts 1, 2)

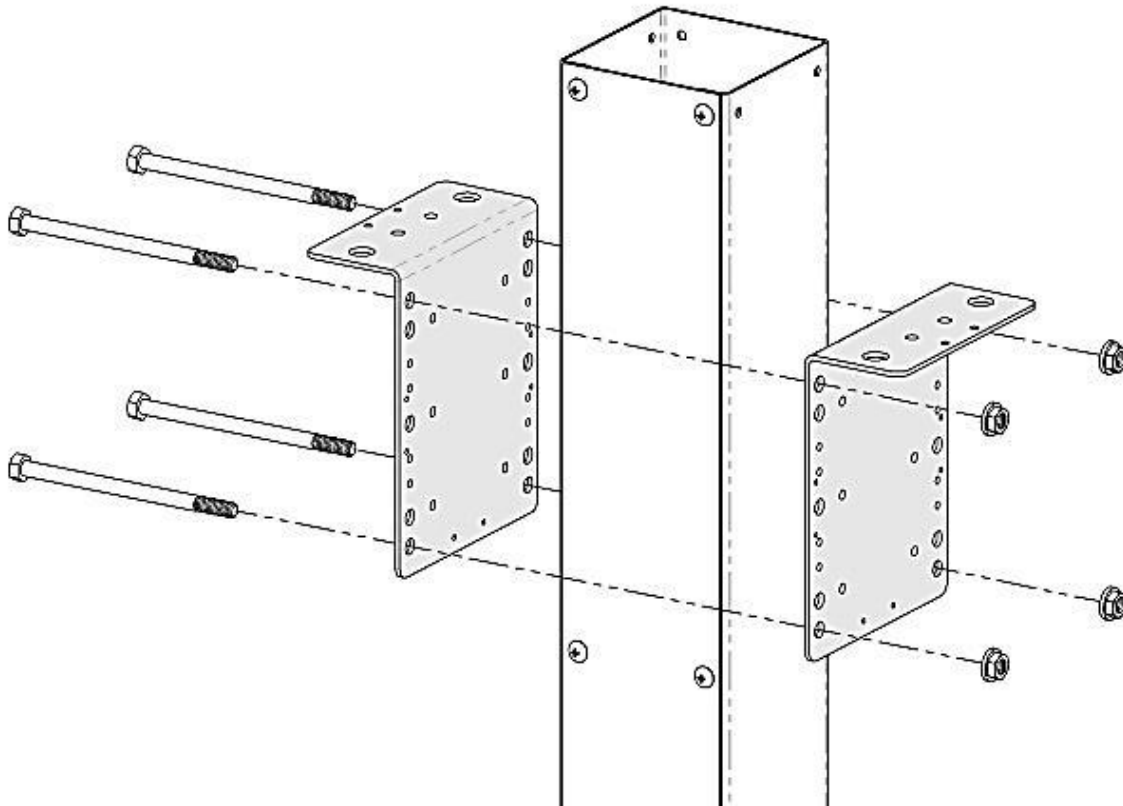

PN 22004 Above Ceiling Mounting Plates Kit

- The Above Ceiling Mounting Plates Kit includes two heavy duty galvanized steel clamping plates that attach to the top of a Channel Extension Section by tightening two pairs of 5/16"-18 bolts on either side of the channel section. This attachment method creates a very secure clamping action against the sides of the channel.
- Self-drilling screws are also included to further secure the plates to way channel section.
- The Above Ceiling Mounting Plates are equipped with multiple threaded holes to allow simplified attachment of standard 2 gang electrical junction boxes directly to the plates as needed. A package of 10-32 X 3/8"L junction box mounting screws is included.
- The Above Ceiling Mounting Plates are equipped with multiple threaded and through holes to allow simplified attachment or bracing materials to secure the wireway to the structure above the ceiling. These bracing materials are not included; but include commonly available items such as channel strut, threaded rods DIY EMT struts and guy wires and additional hardware.
- Refer to the sections:

**Understanding how to attach the of the top of the pole assembly to the structure above the ceiling,
Attaching the Above Ceiling Mounting Plates to the overhead ceiling structure**

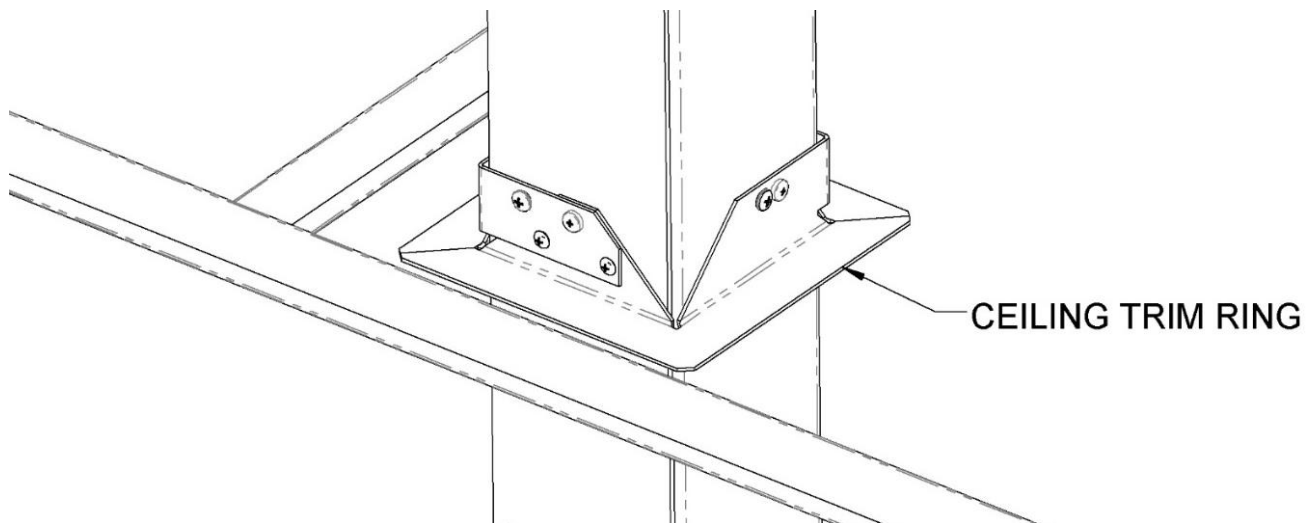
**PN 21262 4X4 Ceiling Trim Ring Kit**

- The Channel Extension Ceiling Trim Ring Kit creates an attractive square finished frame around the location where the Channel Extension penetrates the ceiling.
- The Trim Ring can be attached to the Extension section at any location along its entire length and is secured to the channel section with clamping screws and self- drilling screws.
- The Channel Extension Trim Ring has the same black powder coat finish as the Pedestal Channel, Channel Extension sections, and Cover Plates.
- For installation instructions; refer to the sections:

Installing the Ceiling Trim Ring.**Locating the Pole Assembly in a Suspended Tee Bar ceiling.****Cutting a square opening in the ceiling for the Pole Assembly.**

Assembly and Installation Instructions

Installation instructions Introduction

Important Note 1: Not all sections of these instructions will be applicable to your particular product assembly; however we strongly recommend that you read the entire contents **BEFORE** proceeding with the design of the system, the ordering of assemblies or parts, and before performing any installation work.

Important Note 2: Know that the steps required to assemble these systems are generally listed in the order that they should be performed; however some steps may not be applicable to your particular assembly.

Qualified Installers:

The installation of these systems should only be performed by qualified persons such as journeyman electricians and/ or professional riggers.

Using this document:

You will be prompted at various points throughout these instructions to reference other sections for additional details on various installation procedures. Also included are notes, recommendations and tips intended as helpful suggestions only; DO NOT substitute these for your own best practices or established safety procedures.

Nomenclature:

The terms “Pedestal Channel”, “Channel Assembly”, and “Pole Assembly” may be used interchangeably throughout this document.

Understanding the difference between the two types of channels;

Know that pedestal channels have a series of 6” tall doors installed on the “Open side” of the channel; while Channel Extension sections have Cover Plates installed on the on the “Open side” of the channel.

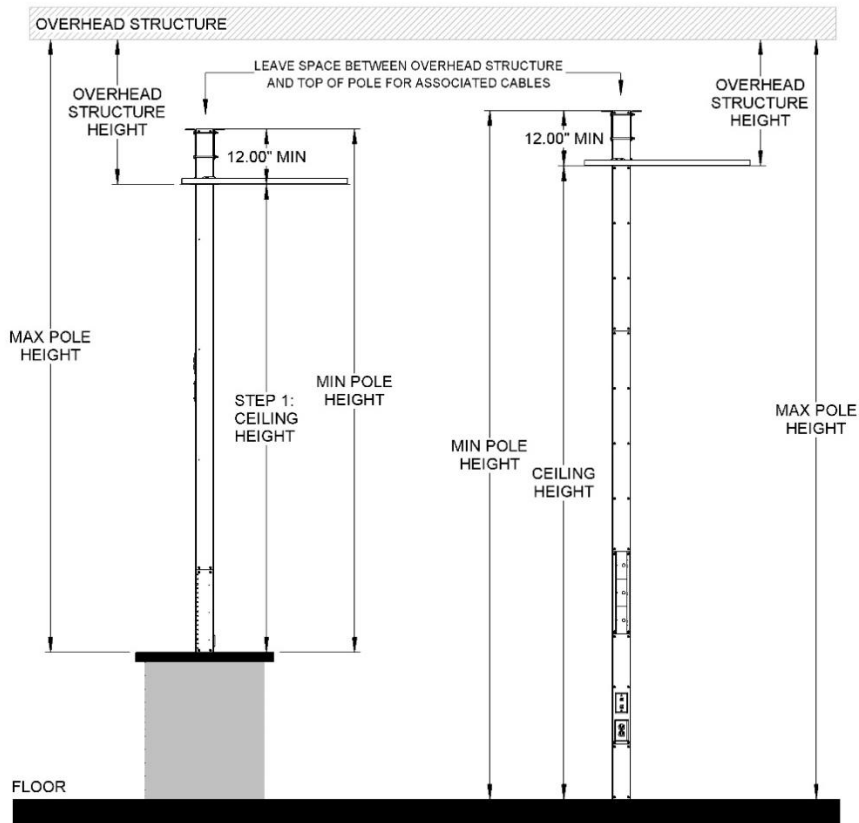

Calculating the vertical height of a 4x4 Pole Assembly that spans to the ceiling

IMPORTANT! : You must calculate the necessary vertical height of the Pole Assembly **BEFORE** placing your equipment order

Step 1 -Measure the distance from the desired attachment point on the floor, countertop or other horizontal mounting surface to the ceiling and record this distance. Take this first measurement and add 12" to allow for the minimum amount of additional vertical channel section that will be needed above the ceiling to attach the assembly to the overhead structure; record this distance. Understand that this total measurement will be the **MINIMUM** length of the vertical Pedestal Channel and / or Channel Extension Assembly that will be needed for your application.

Step 2- Measure the distance from the ceiling to the overhead structure above the ceiling where the Pole Assembly will be installed and record this distance.

Important Note: When determining the maximum height of the vertical section of the Pole Assembly above the ceiling; be sure to factor in some space that will allow the associated conduits and/ or cabling to be fed into the top open end of the wireway channel section while maintaining the minimum bend radius of the conduits and cables and without conflicting with the overhead structure of the ceiling.

Step 3- Add the measurement from Step 1 together with the measurement in Step 2 together and record this total. Understand that this total measurement will be the **MAXIMUM** length of the vertical channel section that can be used for your application.

Step 4 -Compare the two totals found in steps 1 and 3 above and know that the total length of the vertical section needed for your Pole Assembly must be somewhere between them.

Planning the installation of the equipment and associated wiring on a Pole Assembly that spans to the ceiling

1. Create some basic sketches of your Pole Assembly in profile orientation that indicates the following heights:
2. Indicate the total height of the Pole Assembly above the mounting surface, the ceiling height above the mounting surface if applicable, the height of the overhead structure above the ceiling if applicable. Include all of the measurements established in the section “**Calculating the vertical height of a 4x4 Pole Assembly**”.
3. Indicate the heights of the ends of the various arms that will support the various pieces of equipment above the mounting surface.
4. If the bottom of your pole assembly being attached directly to a countertop create a second sketch that indicates where the Base of the Pedestal Channel and / or Extension section with the cable feed through hole will need to be located relative to the front and rear edges of the countertop.
5. Refer to your sketches to address the following considerations and then adjust the design of your system as needed to answer the following questions and consider the following installation notes:
6. If your design includes equipment that must be seen and/ or touched by the system users; is the equipment located at the optimum heights and side to side locations for optimum access by all users?
7. If your pole assembly is going through the ceiling; you'll need to design a supporting structure to connect the above ceiling mounting plates to the structure above the ceiling. Refer to the section: **Attaching the Above Ceiling Mounting Plates to the overhead ceiling structure.**
8. If your pole assembly is going through the ceiling and power and data or other low voltage circuits are intended to be fed down into the pole from the top; you'll need to determine how the associated conduits and/ or wiring circuits are going to be routed across the ceiling and into the top of the pole.
9. If your pole assembly is attached directly to a Countertop, the floor or other surface and the power and data or other low voltage circuits being fed up from below the mounting surface and into the bottom of the pole assembly; you'll need to determine if the cable feed through hole will conflict with structural members, conduits or other items that are located on the underside of the countertop or floor, where the outlets for these circuits will be located and how the wiring circuits are going to be routed from the outlets beneath the Countertop or floor to the cable feed through hole on the bottom of the pole assembly.

Making final connections for power, data or other associated cables to screens, printers and other equipment .

1. If your assembly has a Pedestal Channel with arms that support screens or other equipment; move each arm and each piece of attached equipment to discover the desired full range movement; tie off the cabling and then feed any excess cabling back into the Pedestal Channel.
2. When all of the cables have been connected, perform power up and operational tests on all of the installed equipment.
3. When you are satisfied that all of the equipment is operating correctly; secure all of the cabling inside of the Pedestal Channel using the two sets of hook and loop straps which are located on two opposite sides of the channel interior. We recommend that all high voltage power cabling be kept in one bundle on one side of the pedestal channel and all low voltage cabling be kept in a separate bundle on the other side.

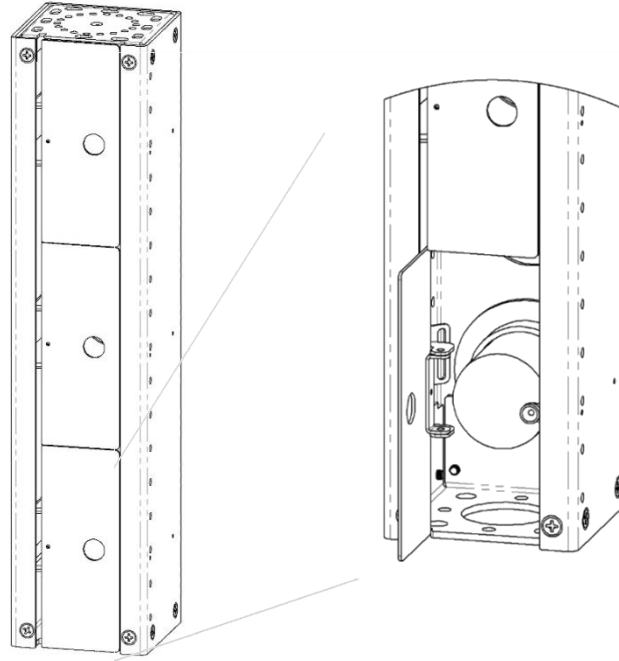

Understanding the basic functions of the Pedestal Channel Assembly

- The Pedestal Channel Assembly is comprised of Pedestal Channel sections used alone or in combination with Channel Extension Sections, via Coupler sections, to create modular 4"X4" square, vertical pole assemblies ranging from 18" to 144".
- Pedestal Channel sections attach to the Mounting Bracket, Couplers, and Top Cap with #10-32 countersunk head Phillips screws.
- Pedestal Channel Assemblies are compatible with Arm Collar Assemblies supporting up to four independent Arm Assemblies, VESA Pan and Tilt Head Assemblies, and 4X4 Clamp On Mount Assemblies to support a variety of accessories.
- Pedestal Channel sections include a series of 2" diameter holes along their entire length that are used to route cables from the interior to the equipment on the outside of the channel. Multiple 6" magnetic latching access doors allow easy interior access.
- Two separate cable tie points are located at 6" intervals attached on opposite sides of the channel interior that are equipped with hook and loop straps.
- Pedestal Channel sections are available in three lengths 18", 36" and 96" and can be configured into a wide range of assemblies and combined with other components; the following configurations are four examples:
 - An 18" or 36" Pedestal Channel Section can be attached to an 18" Round or a 32" Contoured Movable Base for countertop or desktop applications.
 - An 18" Pedestal Channel Section can be attached directly to the mounting surface for countertop or podium applications.
 - An 18" Pedestal Channel section can be coupled to a 36" Channel Extension Section attached to a 22" Round Movable Base to create a 54" floor stand assembly.
 - Pedestal Channel Sections can be coupled to Channel Extension Sections to create assemblies up to 144" with the lower end attached directly to the floor or countertop and the upper end attached to the overhead ceiling structure to create free standing pole applications.
- To understand the difference between the two types of channels; know that pedestal channels have a series of 6" tall doors installed on the "Open side" of the channel; while Channel Extension sections have Cover Plates installed on the on the "Open side" of the channel.

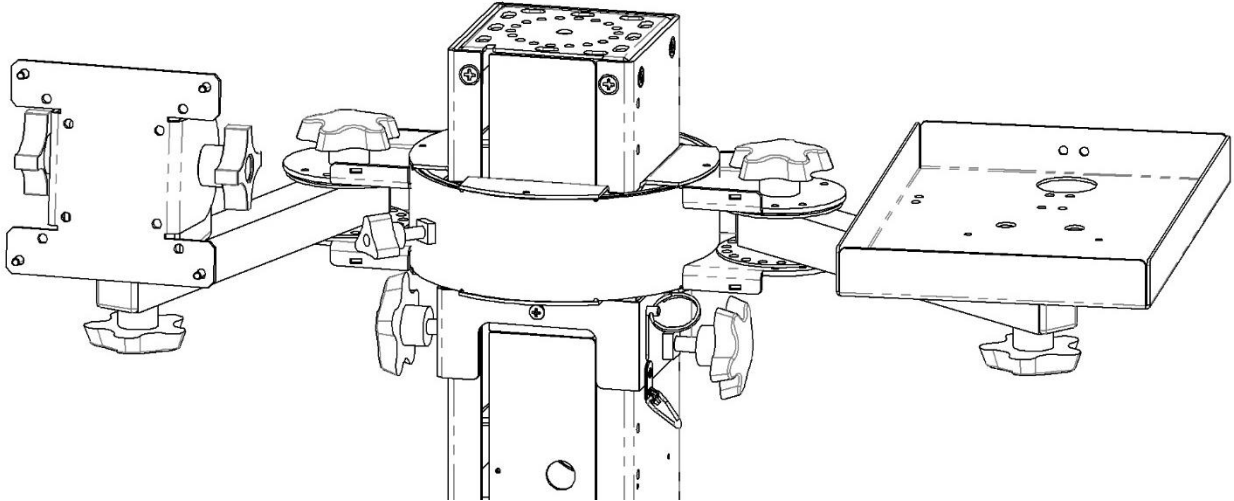

Understanding the basic functions of the Arm Collar Assembly

(Note- Arm collar for two arms shown)

- The Arm Collar Assembly employs a pair of round tube sections to provide adjustable side to side rotation around a pair of square brackets, which provide vertical position adjustment at any point along the length of a 4"X4" pole assembly.
- A pair of 3 point knobs are tightened to secure the desired rotational position of the Arm Collar around the pole and a pair of 5 point knobs are tightened to secure the up and down vertical position of the Arm Collar on the 4x4 pole assembly.
- A safety pin inserted through the lower section of the Arm Collar and into one of the holes in the side of the Pedestal channel section permanently secures the up and down vertical position.
- Arm Collar Assemblies are available with two or four arm mounting points referred to as Stand Off Brackets, and allow mounting of up to 4 independent Arm Assemblies and provide multiple cable tie points.

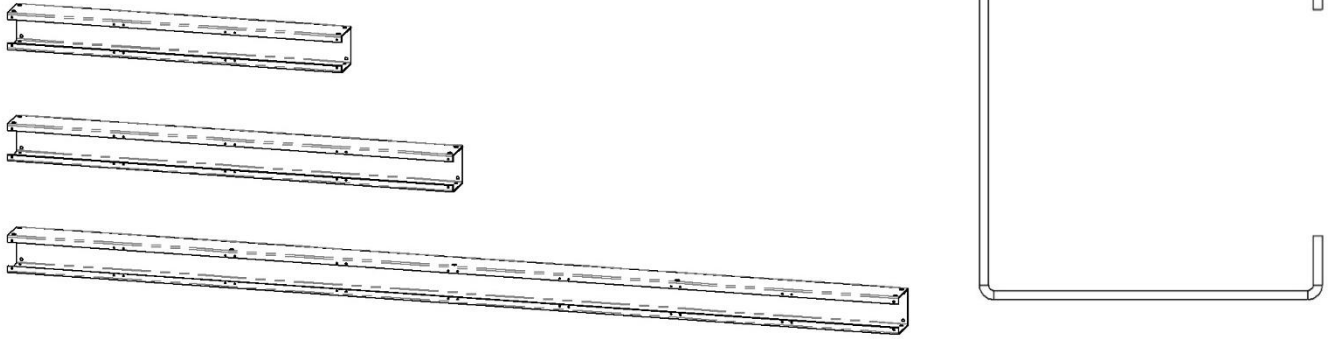

Understanding the Basic Functions of Channel Extension Sections

- Channel Assemblies consist of modular Channel Extension Sections 4"x4" square C channels with three solid sides and one "open" side made of heavy duty steel. Available in 36", 48", and 96" lengths. Channel extensions may be cut to size in-field for applications where necessary.
- Channel Extension Sections can be used alone or in combination with Pedestal Channel Sections via internal coupler sections to create modular, vertical pole assemblies from 36" to 144" H.
- Channel Extension sections can be mounted to a Movable Base, directly to a horizontal surface, or directly to the floor spanning to the ceiling using the Above Ceiling Mount Kit and Trim Ring.
- After installation the channel is enclosed by using Cover Plates to close the open side.
- Cover Plates available in two basic types with multiple lengths:
 - Blank Cover Plates - available in 12", 24", 36", 48" lengths
 - Cover Plates with two outlet Cut Outs- available in 12" and 24" lengths.
- The positions of Cover Plates are interchangeable along the entire length of the open side of a Channel Extension Section. All cover plate kits include 10-32 X 3/8" Phillips countersunk head mounting screws.
- Custom Channel Extension Section Cover Plates can also be ordered with custom cut-outs, custom lengths and in brushed stainless steel finish or a variety of powder coat options. Contact our applications and design team for more information.
- Channel Assemblies are available in multiple configurations:
 - 36" Channel Extension Sections can be used with an 32" Contoured Movable Base for countertop or desktop applications, supporting up to four 32" class screens.
 - 48" Channel Extension Sections can be used with a 22" Round Movable Base and 4X4 clamp On Assemblies for floor stand applications to support any variety of equipment.
 - Channel Extension Sections can be used alone or in combination with Pedestal Channel Sections to create vertical pole assemblies up to 144" total height. The lower end is attached directly to the floor or countertop and the upper end attached to the overhead ceiling structure.
 - To understand the difference between the two types of channels; know that pedestal channels have a series of 6" tall doors installed on the "Open side" of the channel; while Channel Extension sections have Cover Plates installed on the on the "Open side" of the channel.

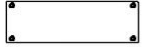

PN 51075 - 12" BLANK

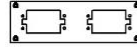

PN 51075 - 12" 2 OUTLET

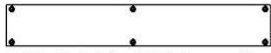

PN 51071 - 24" BLANK

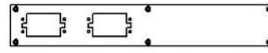

PN 51071 - 24" 2 OUTLET



PN 51070 - 36" BLANK

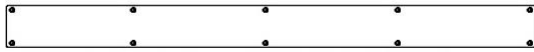

PN 51069 - 48" BLANK

Understanding Channel Extension Cover Plates

- Channel Extension Cover Plates are flat sheet metal panels used to cover the open side of Channel Extension sections. Cover Plates are available in two basic types and varying lengths.
- One type of Channel Extension Cover Plates are smooth, solid blanks with no cut-outs and are available in 12", 24", 36" and 48" lengths.
- One type of Channel Extension Cover Plates has multiple single-gang outlet cut-outs and are available in 12" and 24" lengths, and can be used with or without electrical junction boxes to create power, data or other types of outlets.
- Cover Plates are attached to the Channel Extension sections using #10-32 X 3/8" L Countersunk Phillips Head Stainless steel screws. All Cover Plate kits include mounting screws
- Cover Plate positions are interchangeable along the entire length of the Channel Extension section.
- Channel Extension cover plates have black powder coat finish.
- Custom Channel Extension Cover Plates can also be ordered with custom cut-outs, lengths, and finishes such as brushed stainless steel or a variety of powder coat options. Contact our applications and design team for more information.

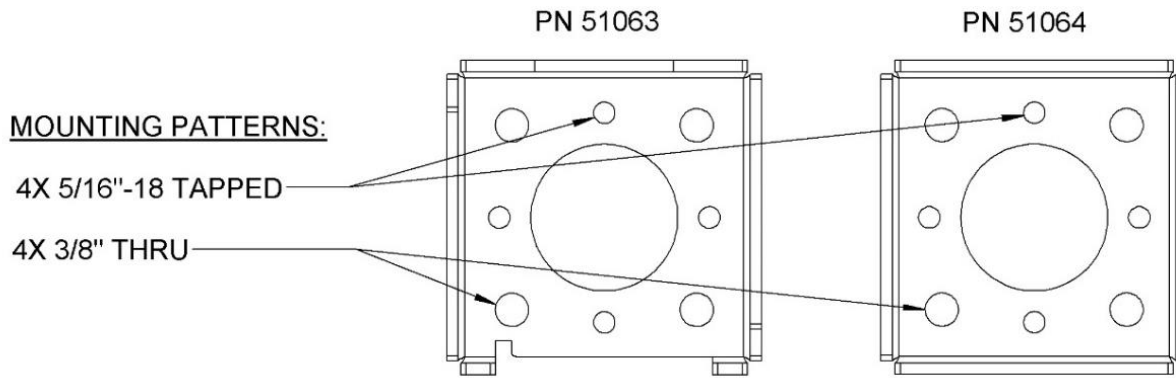

Locating and installing a base mounting bracket

1. If you have not already done so; temporarily install the Feed Through mounting base Bracket onto the bottom of the assembled Pole Assembly.
2. Carefully lift and support the Pole Assembly in the vertical position and securely attach the safety restraint assembly to the overhead structure in a manner to prevent the Pole Assembly` from falling. Once the Pole Assembly is stabilized; carefully shift the bottom of the assembly so that the Feed Through mounting plate base is aligned correctly with the mounting surface.
3. Use a marker to transfer the positions of the large center feed through hole and all of the mounting hole locations in the Feed Through base plate onto the mounting surface. Use a level to double check for correct vertical alignment of the Pole Assembly.
4. Important note – Make a label with the letter “F” or the word “front” directly and place it onto the mounting surface to indicate the correct orientation of the open side or outlet side of the channel section.
5. Carefully support the Pole Assembly, remove the six 10-32 screws that attach the bottom of Pole Assembly to the three closed sides of the mounting plate base and then remove the base plate.

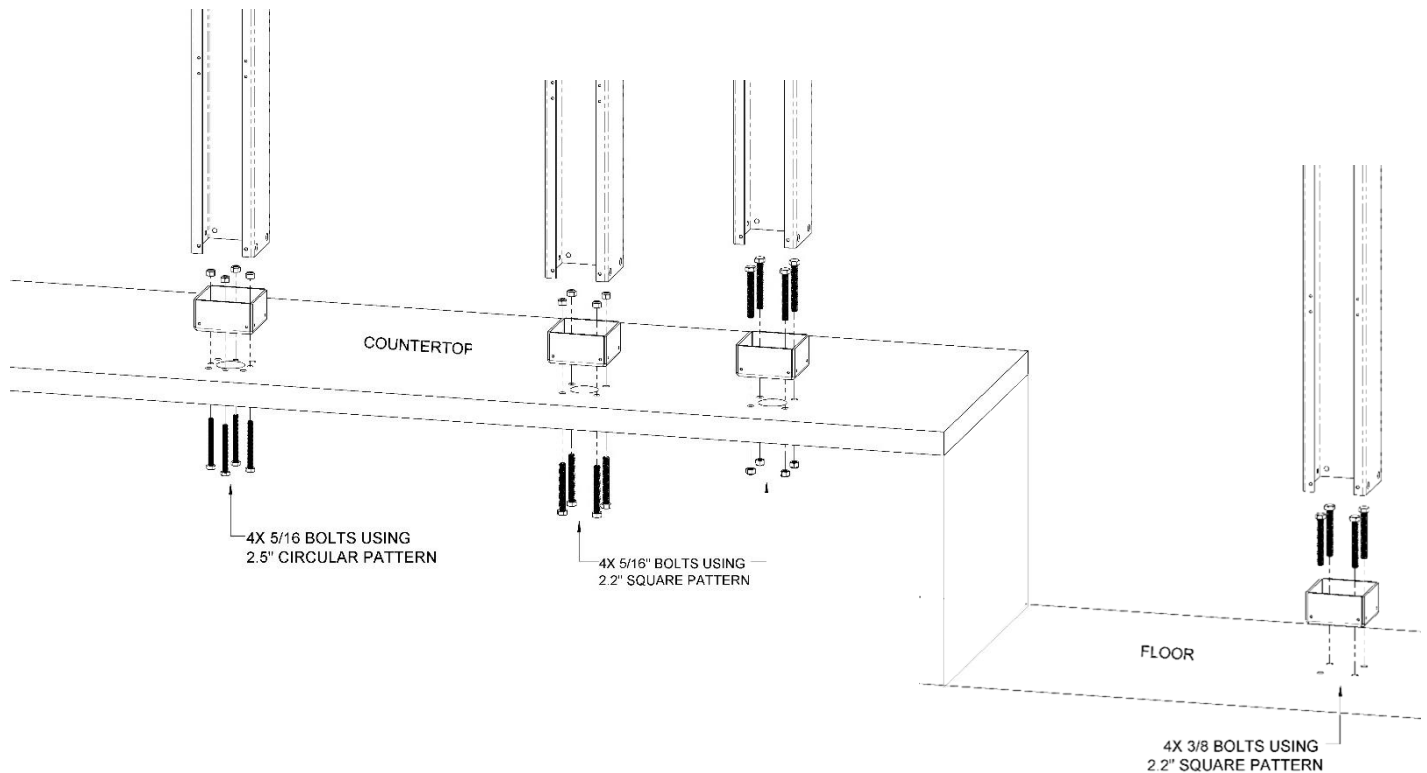

Permanently attaching the Feed Through mounting base bracket to the mounting surface

1. Once the feed through hole has been made in the mounting surface; place the mounting base plate on the mounting surface. That the open side of the Pole Assembly is aligned correctly with the letter "F" or the word "front" written on to the mounting surface. Then align the center hole and mounting holes in the plate with the center hole and marks on the mounting surface and install the appropriate fasteners through the holes in the mounting base plate to permanently secure it to the mounting surface.

2. Once the Feed Through mounting Bracket is permanently attached to the mounting surface; carefully support the Pole Assembly, lift the bottom of the Pole Assembly and align the open side of the bottom of the Pole Assembly with the shorter flange on the base plate; then reinstall the (8) 10-32 Phillips Countersunk head screws that attach the bottom of the Pole Assembly to the four sides of mounting Bracket.

Option 1= If you are attaching the mounting bracket to a countertop; install 4 EA 5/16" bolts up from the underside of the countertop and into the tapped holes in the mounting bracket.

Option 2= If you are attaching the mounting bracket to a floor; install 4 EA 3/8" anchors in the floor and install 3/8" bolts through the 3/8" holes in and into appropriate anchor installed in the floor.

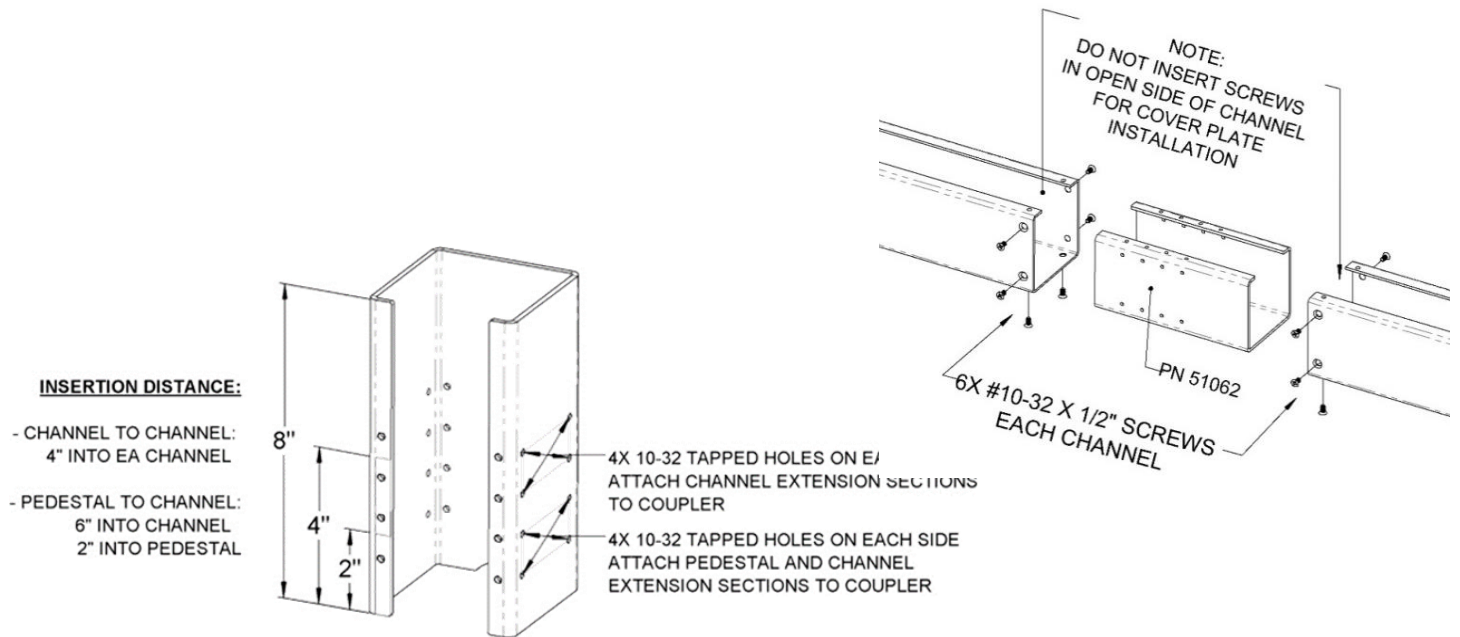

Pre-assembling the Pole Assembly and installing an internal coupler to connect two Channel Extension sections

1. If your Pole assembly is made of separate sections; the first step is to use an internal coupler and screws to connect the channel sections together to create a single vertical assembly. Do not install the cover plates at this time.
2. Once you have the channel section completely assembled; verify the correct orientation of the open or cover plate / outlet side of the wireway channel section assembly relative to which direction you would like the cover plate with the outlets to face.
3. The internal coupler is 8" long, made of thick galvanized steel and is used to join any two channel Extension sections of together end to end. Lay the two Pedestal Extension sections that are to be joined together on a flat surface so that the open sides of both channels are facing up and the ends of each section are approximately one foot apart.
4. Note that there are four sets of eight tapped holes; the two sets of tapped holes located in the center of the coupler are used to join two channel Extension sections together. Use the two sets of 8 holes located at the center of the coupler so that 4" of the 8" L coupler is inserted into each channel extension section
5. Orient the coupler so that the open side in the coupler is facing up and is aligned with the open sides of the two Extension sections and then carefully slide the coupler 4 inches into the end of one of the Extension sections, align the first set of eight tapped holes in the center of the coupler with the eight through holes in the channel and then install six screws into each of the holes on the three closed sides of the Extension section.
6. Carefully guide the second Extension section onto the free end of the coupler until it stops against the end of the first channel section and then install six screws into each of the holes on the three closed sides of this channel section.
7. Install the 6EA 10-32 screws on three closed sides of the channel first; then install the fasteners on the open side. Note that the screws on the open side of the channel will be installed in the holes in the end of the cover plate.

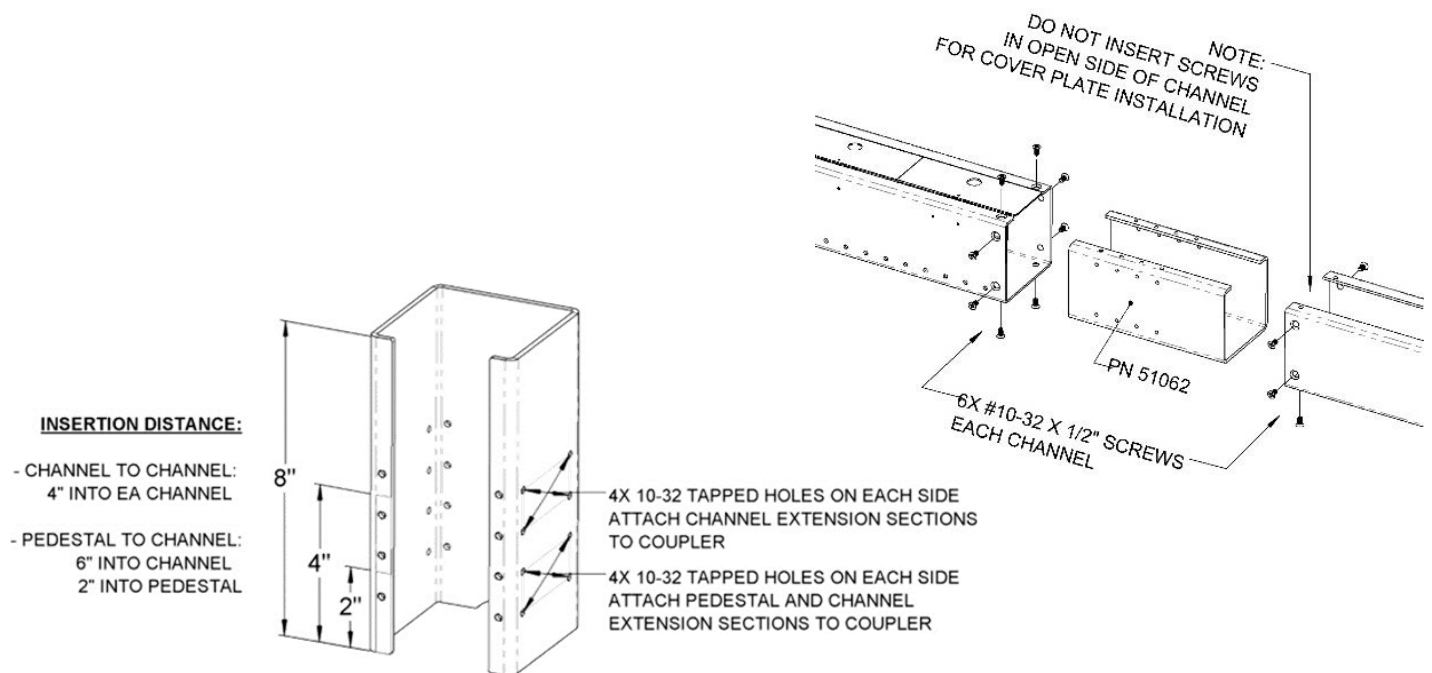

Pre-assembling the Pole Assembly and installing an internal coupler to connect a Pedestal Channel Section to a Channel Extension section

1. The internal coupler is 8" long, made of thick galvanized steel and is used to join either two Channel Extension sections or a Pedestal Channel Section to a Channel Extension section together end to end.
2. Lay the Pedestal Channel Section and the Channel Extension section that are to be joined together on a flat surface so that the open sides of both channels are facing up and the ends of each section are approximately one foot apart.
3. Note that there are four sets of eight tapped holes in the coupler; the two sets located closer to one end of the coupler are used to join a Pedestal Channel Section and a Channel Extension section together. Use the two sets of 8 holes located at the end of the coupler so that 2" of the 8" L coupler is inserted into the pedestal channel section and 6" is inserted into the channel extension section
4. Orient the coupler so that the open side in the coupler is facing up and is aligned with the open sides of the Channel Extension section and a Pedestal Channel Section.
5. Carefully slide the coupler 6 inches into the end of the Extension section and align the first set of eight tapped holes and then install six Countersunk head screws into each of the holes on the three closed sides of the Extension section. Note that the two screws on the open side of the Extension section will be installed later in the holes in the end of the cover plate.
6. Carefully guide the Pedestal Channel Section 2 inches onto the free end of the coupler until it stops against the end of the Extension section, the remaining eight tapped holes in the coupler align with the eight through holes in the Pedestal channel section and then install eight Countersunk head screws into each of the holes on the all four sides the Pedestal channel section.

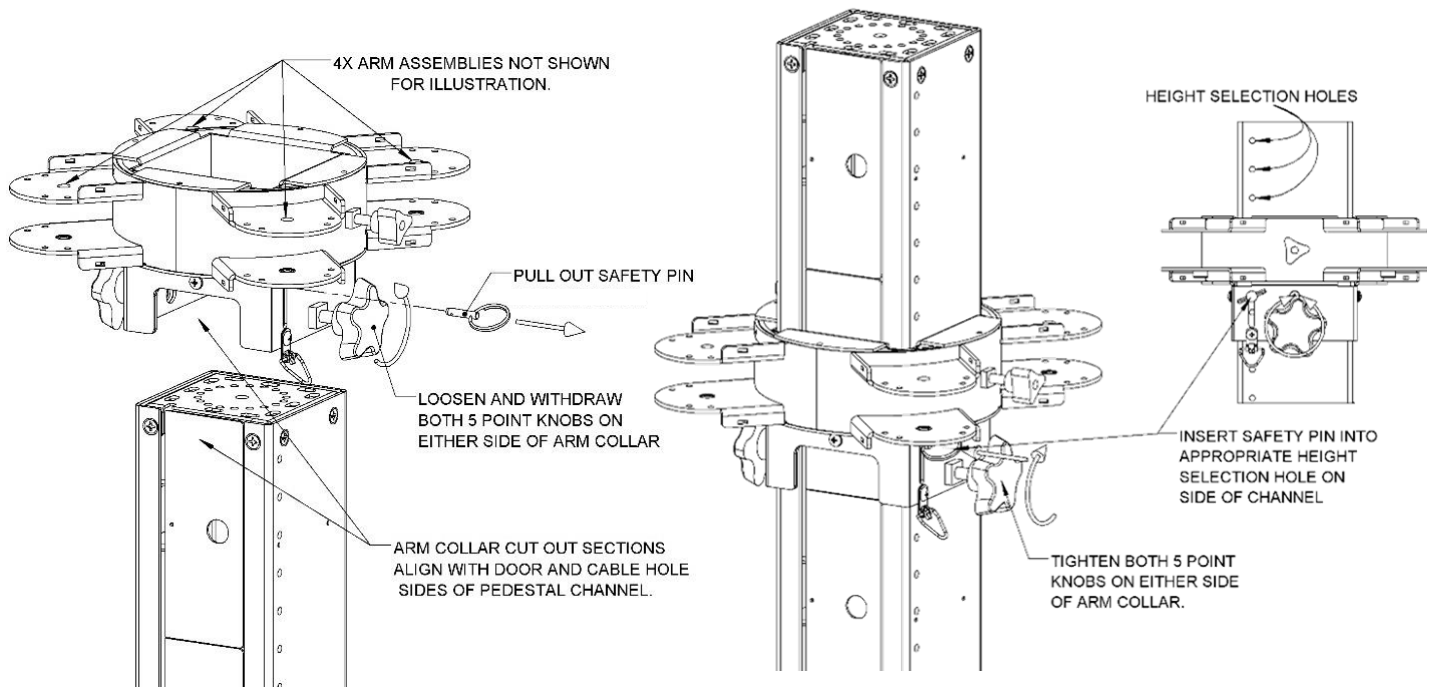

Installing an Arm Collar Assembly onto a Pedestal Channel section

1. As shipped; all arm collar assemblies will require partial assembly in that they will need to have items such as pan and tilt heads, printer trays and lower arm assemblies reattached. Install the arm collar assembly onto the pedestal before reattaching these items.
2. If an Extended Pan and Tilt head assembly is installed on the top cap; remove it by opening the top most door, unscrewing the five point knob, lift off the Pan and Tilt head and rubber clutch washer, place the rubber washer on the shaft of the knob and then screw the knob into the pan base of the Pan and Tilt head assembly.
3. Verify that the two five point knobs located on the sides of arm collar are fully loosen that the ends of the shafts are fully withdrawn into the sides of the arm collar assembly.
4. Verify that the two three point knobs on the sides of arm collar assembly are secure and the outer collar cannot rotate around the inner section.
5. Verify that all of the five point knobs located on the stand off brackets around the sides of the arm collar assembly are secure and the arms cannot move.
6. Verify that the safety pin is removed from the slot on the side of the arm collar assembly.
7. Verify that all of the doors on the pedestal channel are closed and no items are protruding out of the cable path holes.
8. The arm collar assembly is installed with the stand- off brackets on the top and the two cut out sections are on the bottom.
9. Lift the arm collar assembly above the top of the pedestal; align the two sides with the cut out sections with the side that has the cable path hole and the side with the doors and carefully slide the square opening in the center of the arm collar assembly down over the top of the pedestal channel.
10. Move the arm collar assembly down to its final vertical location of the pedestal channel, insert the safety pin into the hole inside of the slot on the side of the arm collar assembly and then tighten the two five point knobs located on the sides of arm collar.

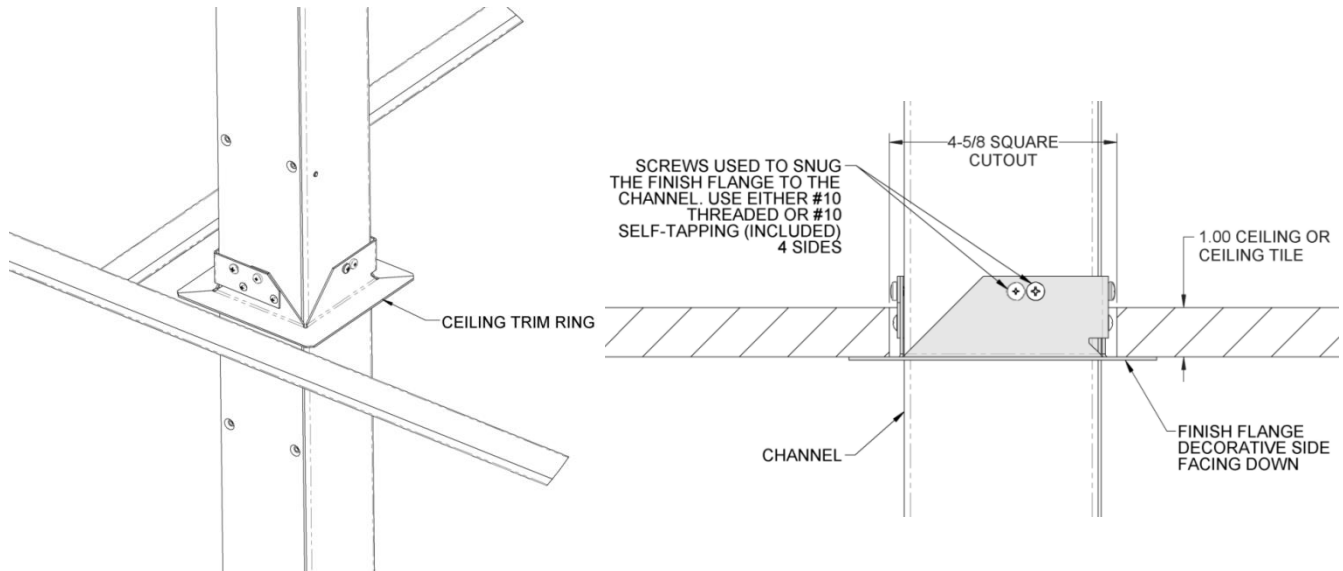

Locating the Pole Assembly in a Suspended Tee Bar ceiling

1. If your ceiling is a suspended "Tee Bar" type; the best scenario is if the top of the Pole Assembly can be located in one of the corners of the metal Tee bar grid.
2. A second-best choice would be to locate the Pole Assembly directly against one of the sides of a section of the Tee bar. Using either of these techniques will make it much easier to cut and reinstall the ceiling tile so that the Pole Assembly can pass through it.
3. If neither of these techniques will work in your situation; you can still fabricate some custom sections of Tee Bar and ceiling tile to fill in around the area where the Pole Assembly penetrates the ceiling grid.
4. Locating the top of a Pole Assembly in the ceiling -Use a laser level or a plumb bob suspended from the ceiling to locate the side to side and forward and back center position of the assembly. Mark this location on the ceiling and on the floor or other horizontal mounting surface.

Cutting a square opening in the ceiling for the Pole Assembly

1. You will need to cut a square hole that is 4 $\frac{3}{4}$ " W X 4 $\frac{3}{4}$ " D in your ceiling material.
2. The horizontal frame of the Ceiling trim ring extends 1 inch out from the vertical flanges and should cover any rough edges.
3. Important note- The two taller, pointed, vertical flanges on the Ceiling Trim Ring assembly must extend up through the ceiling surface so that mounting screws for the trim ring can be accessed from above the ceiling.

ABOVE CEILING
MOUNTING PLATE
KIT PN 22004

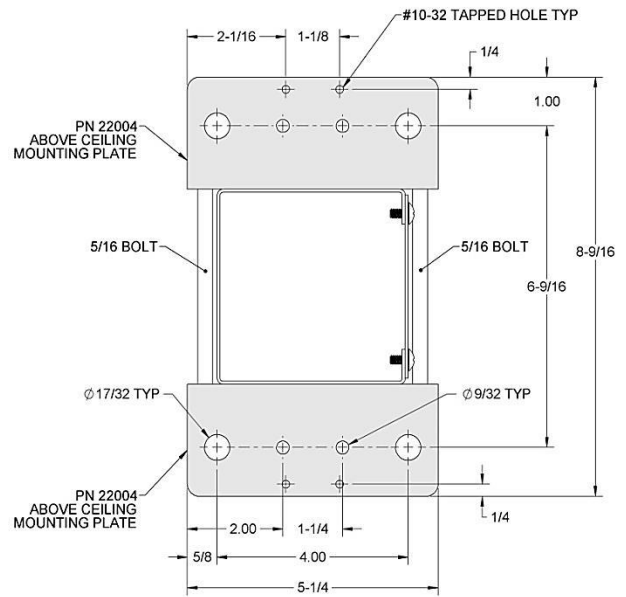
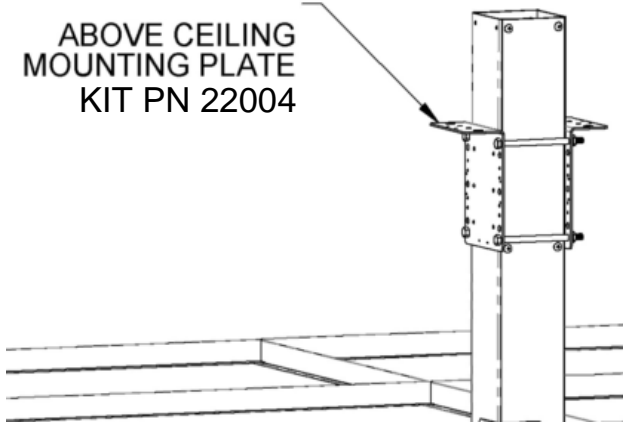

Understanding how to attach the top of the pole assembly to the structure above the ceiling

1. Survey the area above the ceiling and identify the appropriate overhead structure elements which are above and adjacent to the top of the channel location for attaching the bracing structure.
2. Measure and record the distance from the top of the channel to the overhead structure above the ceiling. You will need these measurements to help design, fabric and install the additional items such as user supplied threaded rod, channel strut, angle brackets or DIY EMT conduit struts and miscellaneous hardware needed to attach the Above Ceiling Mounting Plates to the structure above the ceiling. Refer to the section: **Attaching the Above Ceiling Mounting Plates to the overhead ceiling structure**

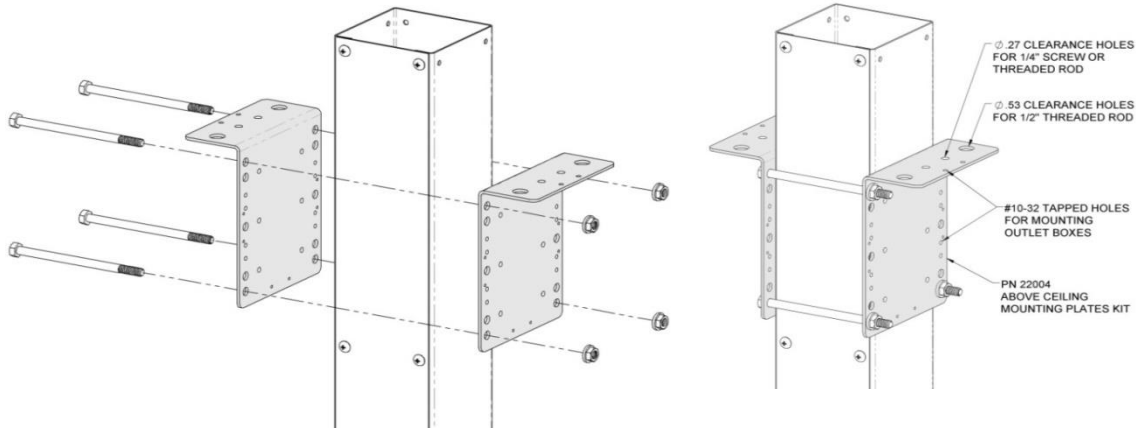

Attaching the Above Ceiling Mounting Plates to the top of the Pole Assembly

1. Before proceeding, while the pole assembly is still at floor level; identify the Above Ceiling Mounting Plates Kit. Review how this system attaches via a clamping action to the two solid sides at any point along the length of the channel section that extends above the ceiling.
2. Consider the optimum height the Above Ceiling Mounting Plates should be located on the pole assembly for your installation scenario and mark this location on the channel section. With the channel assembly still at floor level; orient the two Above Ceiling Mounting Plates so that they will lay against the two solid sides of the channel and then install the included 4 EA 5/16"-18 X 5"L bolts and lock nuts through the holes in both Mounting Plates and across both of the solid sides of the channel section.
3. Position the plates so that they align with the mark you made in the last step; then use 1/2" wrenches to carefully tighten these fasteners just enough to secure the plates to the channel at the desired height. Do not overtighten as you may crush the channel. Install a self-drilling screw through one of the holes in each of the Above Ceiling Mounting Plates and into the sides of the channel section to further secure the plates to the channel.
4. Before proceeding; you must acquire and install a safety restraint assembly (not included) that is securely attached to the top of the channel assembly that can also be attached to the overhead structure as soon as the channel section is raised to the vertical position.
5. Important note - be aware that BEFORE the associated conduits and or cabling and the top most cover plate and the ceiling trim ring has been installed on the channel assembly; you must be sure to return to the top of the channel assembly and finish tightening the 4 EA 5/16"-18 X 5"L bolts and lock nuts that secure the Above Ceiling Mounting Plates to the top of the Pole Assembly.
6. Adding a safety restraint to secure the top of the Pole Assembly; In order to ensure the stability of the Pole Assembly the installer must now source and / or fabricate a safety restraint assembly made of cable, wire, chain or other suitable flexible material and attach it to both of the Above Ceiling Mounting Plates and to the overhead structure. This safety restraint assembly must be kept properly tensioned to prevent the Pole Assembly from falling until the Above Ceiling Mounting Plates are permanently attached to the overhead structure.
7. Permanently Securing the Above Ceiling Mounting Plates -VERY IMPORTANT- before all of the associated conduits, cabling, the cover plates and the Ceiling trim ring have all been installed on the Pole Assembly; return to the Above Ceiling Mounting Plates and fully tighten the (4) EA 5/16"-18 X 5" long bolts and lock nuts that secure the Mounting Plates to the Pole Assembly.

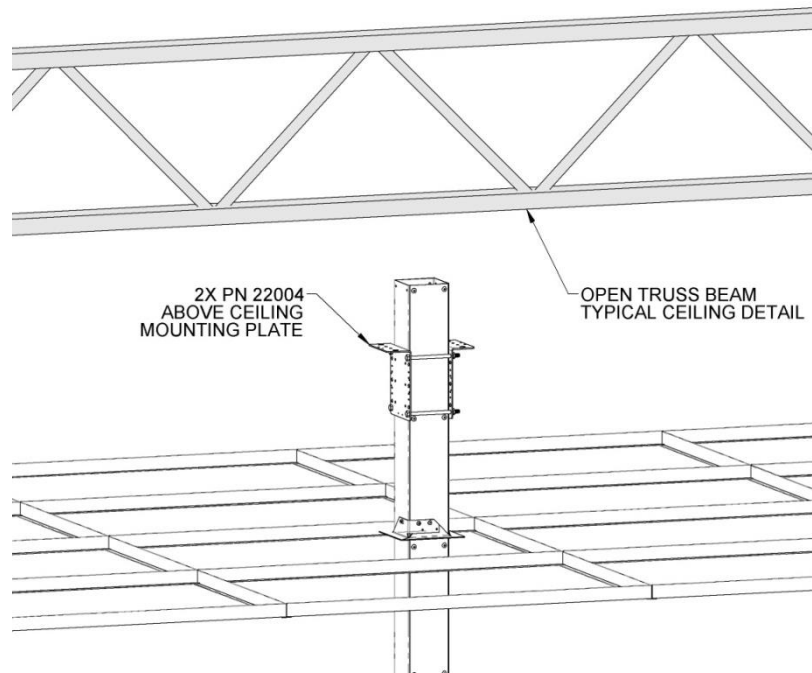

Attaching the Above Ceiling Mounting Plates to the overhead ceiling structure

Once the Feed Through mounting base plate is permanently attached to the mounting location and the bottom of the channel assembly is attached base plate; you'll need to return to the top of the Pole Assembly and attach the Above Ceiling Mounting Plates to the overhead ceiling structure.



For this step; you will need to design, fabricate and install a custom support assembly consisting of threaded rods, channel strut, steel angle, guide wires, beam clamps, EMT conduit struts or other suitable materials and hardware as needed to securely brace and permanently attach the Above Ceiling Mounting Plates which are attached to the top of the channel assembly. These bracing materials are not included; but are commonly available.

Fabricating bracing struts with EMT conduit to brace the top of a Pedestal Extension Section

One method of bracing the Above Ceiling Mounting Plates that attach the top of the Pedestal Extension Section to the overhead structure is to fabricate custom length steel tubing struts made out of common EMT conduit. It is important to consult with your local building and safety department to verify if this type of bracing is or is not permitted in your jurisdiction. The attachment points on the ends of the struts can be made by flattening the last few inches of the conduit section, drilling through holes that are large enough for your fasteners in the flat sections and then carefully bending the flattened sections to create mounting flanges. We recommend using $\frac{3}{4}$ " trade size or larger EMT conduit for making these struts.

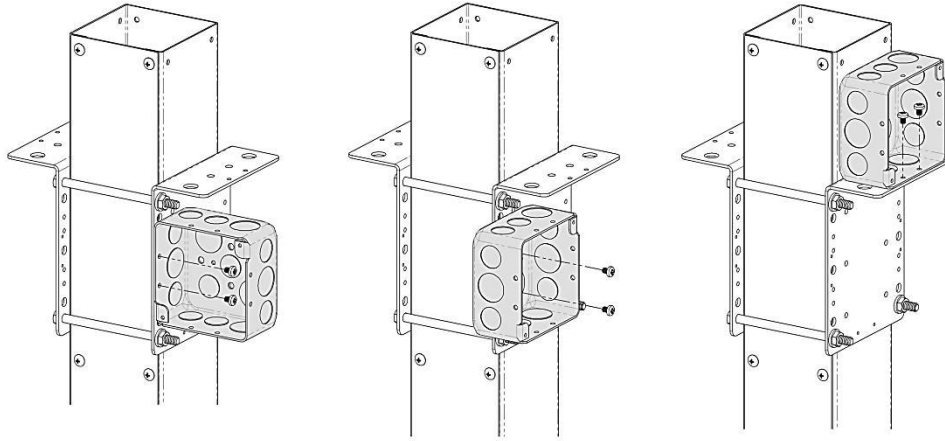

Attaching Junction boxes to the Above Ceiling Mounting Plates

- The Above Ceiling Mounting Plates are also equipped with multiple threaded holes to allow simplified attachment of standard 4" X 4" or 5" X 5" electrical junction boxes as needed.
- The tapped holes are located on then horizontal and the vertical planes of the mounting plates to allow a range of options for attaching either with the side or the back of the junction box flat against the mounting plates. 10-32 junction box mounting screws are included in the hardware Kit.

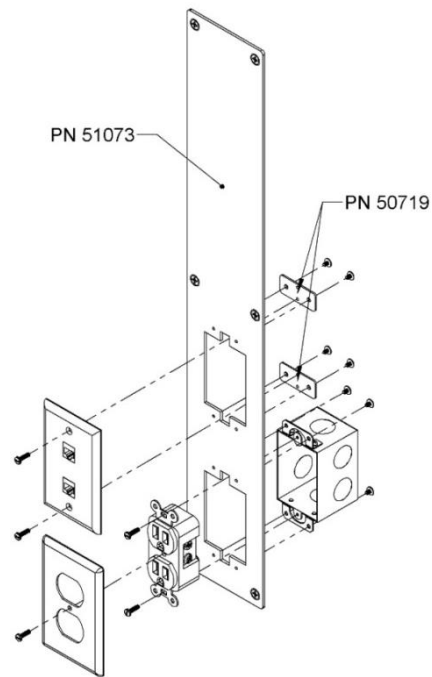

Assembling and connecting the outlets on the cover plates

- Identify the cover plates with the outlet cut- outs. Also locate all of the junction boxes, faceplates, receptacles and all other items necessary to assemble the various outlets in your assembly, reference the lists of included items for your assembly.
- All outlet cut-outs on channel extension section cover plates are sized to fit a standard 3”H x 2” W “cut in type” single gang junction box with mounting brackets and any standard faceplate.
- “Cut in type” single gang junction box are available in a range of different depths and all are equipped with two L shaped mounting brackets with one end of each bracket attached to the end of the junction box with two screws. Two additional 10-32 screws are used to attach the other end of each L bracket to the rear / inside of the cover plates over the outlet cut- outs. Junction boxes with mounting brackets are Zinc Plated and available with both ½” and ¾” trade size knock outs for connecting conduit.
- If your assembly includes outlets 3”H x 2” W X 2 ½” D “cut in type” single gang junction and your application requires deeper junction boxes; refer to the list: Know that using junction boxes that are deeper than the standard 2 ½” depth will REDUCE the conduit and cabling loading capacity of the channel extension.
- Consult your local building codes to determine if conduits are required above the ceiling and/or conduit and junction boxes are required inside of the vertical wireway for your new data or other low voltage or cabling circuits. If you ARE permitted to install the data cabling circuits inside of the vertical wireway WITHOUT conduit and junction boxes; know that you can also install Low voltage, Data or blank faceplates on any outlet cut- out without a junction box by using a PN 21208 NO J BOX Faceplate Adapter Kit.

Create a layout for the outlets in the Channel Extension cover plates

- Know that all of the single gang outlet cutouts on the cover plates can be used interchangeably for power, data or other applications.
- Review the various desired locations of all the power and data outlets on your assembly.
- Create labels made of blue painter’s tape and then apply these directly onto the Channel Extension sections to indicate the assignment of each of the outlet cutouts in cover plates that will be used in your application.

PN 50719 NO J BOX Faceplate Adapter plates are used to attach Data and blank faceplates to the cut-outs in the cover plates with (4) PN 70415 #6-32 X 3/16 "long Phillips head screws

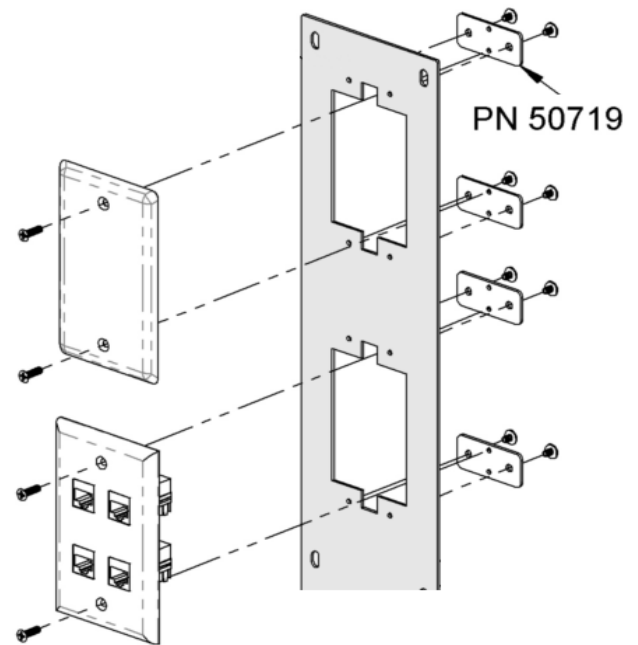
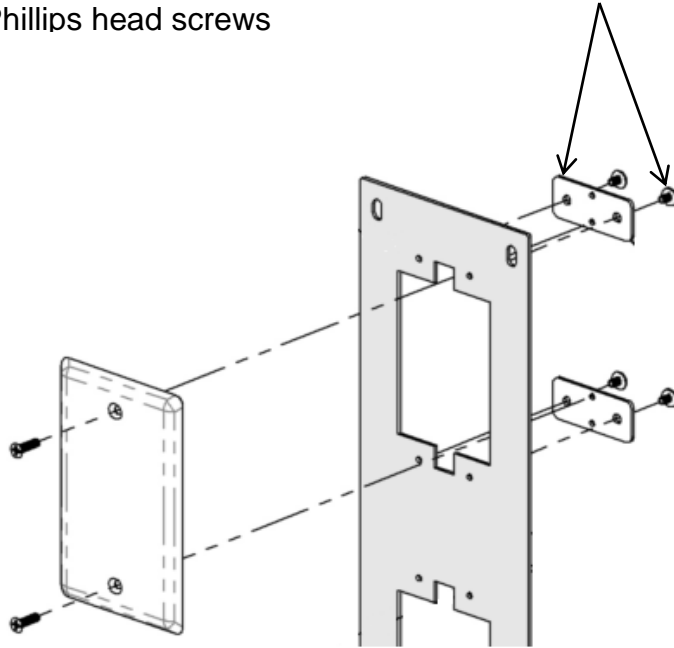

Attaching Data and blank faceplates directly to the outlet cut-outs WITHOUT junction boxes with PN 21208 NO J BOX Faceplate Adapter

Using a PN 21208 NO J BOX Faceplate Adapter kit to attach Data, blank or other single gang faceplates to the cut-outs on channel extension section cover plates

1. Use 2 EA PN 70415 #6-32 X 3/16 "long Phillips head screws to attach the PN 50719 Faceplate Adapter plates to the top and bottom of the outlet cut-outs on the inside of the channel extension section cover plates.
2. Once the Faceplate Adapter plates are installed; any standard single gang faceplate can be attached to the Faceplate Adapter plates with 6-32 screws.

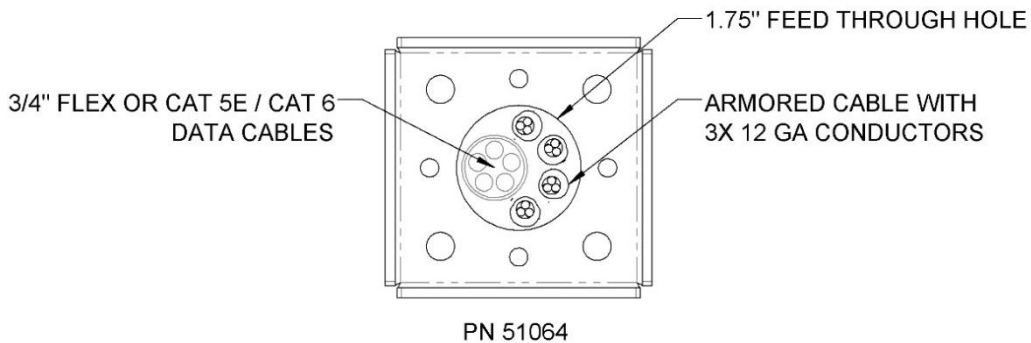
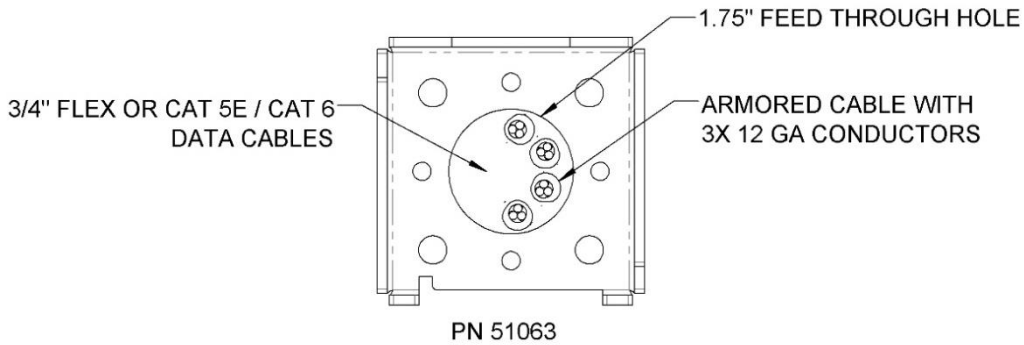

Installing the associated conduits and cabling into the Pole Assembly

- Create a wiring list that includes all of the various types of new high and low voltage cabling circuits that will be needed to connect all of the various types of outlets on your assembly.
- Consult your local building codes to determine the types of cabling and conduits that are required.
- It is recommended that the high voltage circuits be installed with armored cable or flexible metallic conduit to a junction box that is attached to the Above Ceiling Mounting Plates near the top of the Pole Assembly.
- Add "whip sections" of armored cable or flexible metallic conduit from the junction box attached to the Above Ceiling Mounting Plates or somewhere above the ceiling to extend these circuits from this junction box to the various junction boxes located at the power outlets in the cover plates.
- If your channel assembly has outlets; refer to the sections:

Assembling and connecting the outlets on the channel extension cover plates

Attaching Junction boxes or faceplates to outlet cut-outs on cover plates

Installing cover plates on Channel Extension sections

- Consult your local building codes to determine if conduits are required above the ceiling and/or inside of the channel Extension section for your new low voltage or data cabling circuits. If you are permitted to install the data cabling circuits inside of the wireway WITHOUT conduit; know that Data faceplates can be attached directly to the outlet cutouts WITHOUT junction boxes by using a PN 21208 NO J BOX Faceplate Adapter Kit.

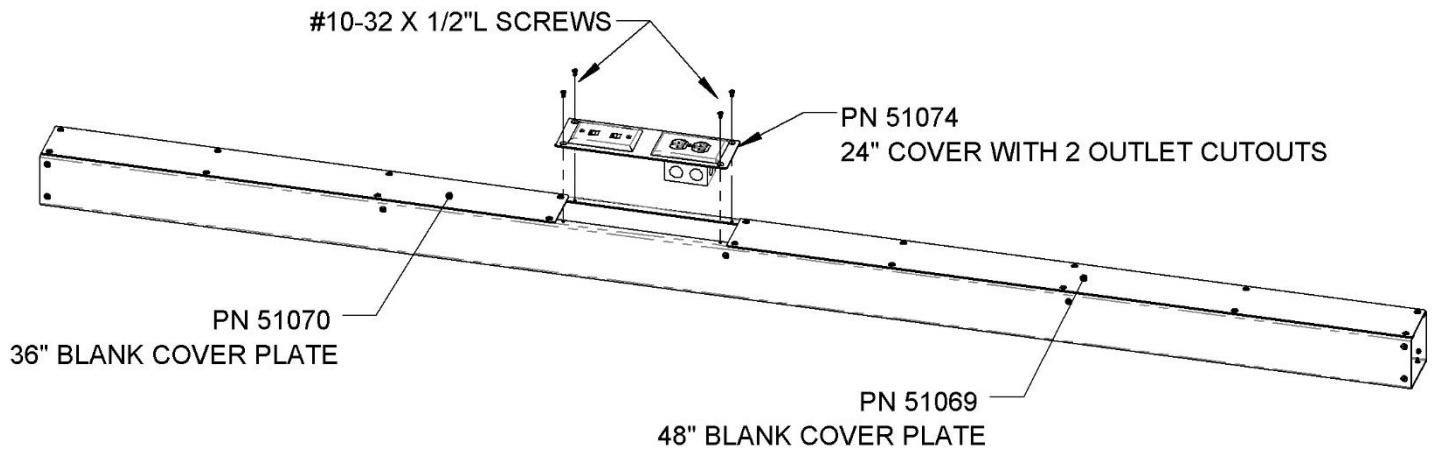

Installing Cover Plates on Channel Extension sections

1. Installing the cover plates should be the last step in assembling your Channel Extension assembly.
2. Locate the 10-32 X 1/2" long Phillips Countersunk screws in the hardware kit.
3. Align the holes in the cover plates with the tapped holes in the open side of the extension sections and then install one screw loosely through each of the holes in the cover plates and into the tapped holes extension sections.
4. Once all of the screws have been installed, verify that the alignment of all cover plates is correct, adjust the position of any covers plates as needed, then return to each screw and tighten them securely.

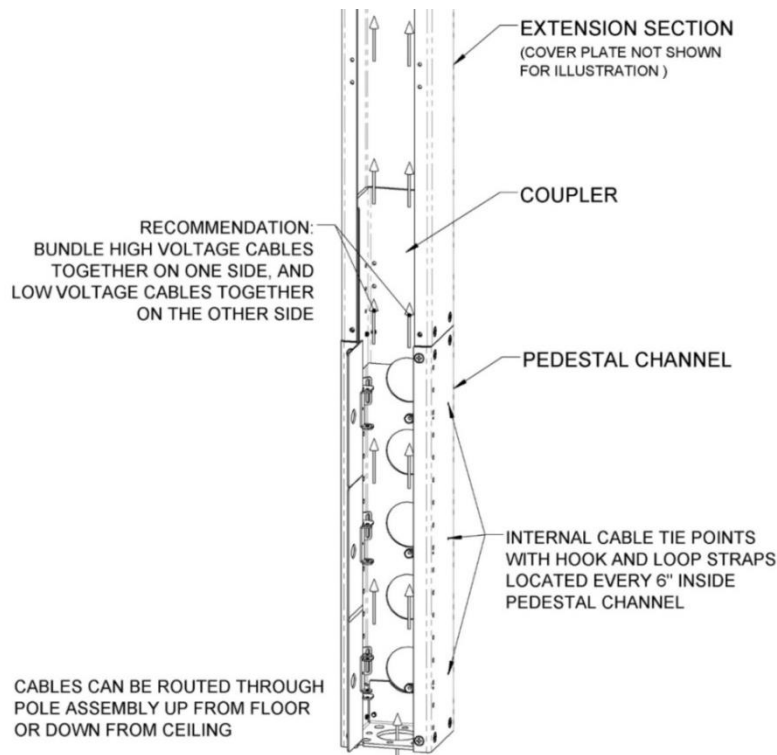

Installing and routing the power and other associated cables through a Pedestal Channel and an Extension Section with Coupler

- All components have been designed to ease the installation of any associated wiring within the assemblies:
- All Pedestal Channel sections, Channel Extension Sections and Couplers have an internal vertical cable pathway that is approximately 3 3/4" W X 3 3/4" D square.
- All Pedestal Channel sections include a series of 2" diameter cable passage holes along their entire length that are used to route cabling from the interior cable pathway to the equipment on the outside of the channel.
- All Pedestal Channel sections include multiple 6"H access doors with magnetic latches to allow easy access to the interior of the channel without tools.
- Pedestal Channel sections include two separate sets of cable management tie points located at 6" intervals attached on opposite sides of the channel interior, both equipped with hook and loop straps.
- **Recommendation:** Route and bundle all high voltage power cabling on one side of the channel and all low voltage cabling in a separate bundle on the other side.
- The Extension Section mounting base includes a 1.75" diameter round hole in the center for cable passage use the provided spiral wrap to protect the cabling where it transitions into the base of the pedestal from under the Base plate
- The Arm Collar Assembly includes multiple cable tie points on the stand off brackets where arms attach.
- All types of VESA Pan and Tilt head assemblies include a cross spacer behind the head assembly where cable ties can be looped over to secure cabling.
- Printer and Peripherals Tray includes a 1" diameter cable path hole and multiple pairs of small holes to feed cable ties through.

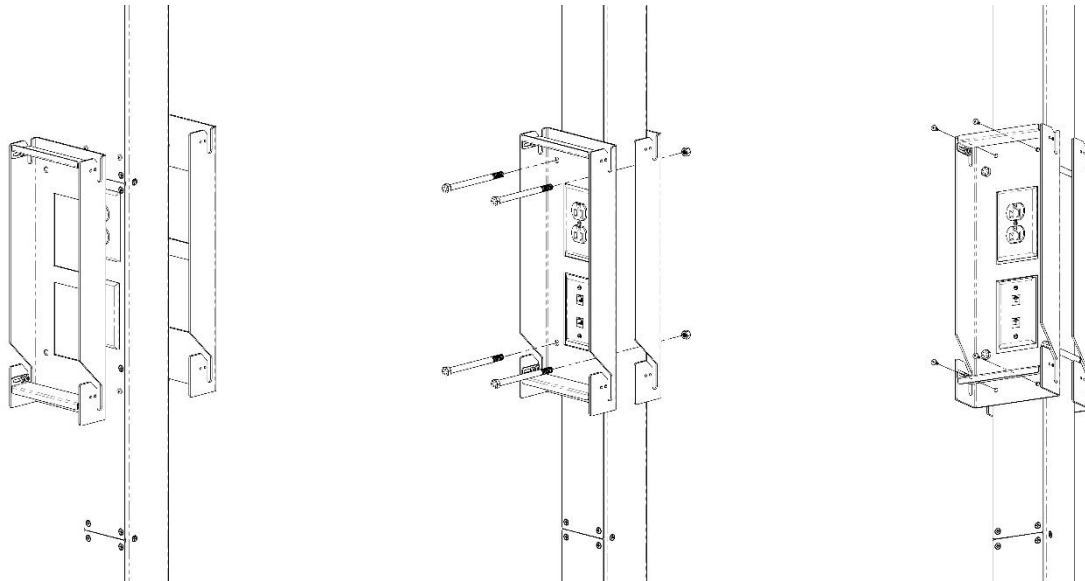

Installing the 4X4 Clamp On 100-400mm VESA Tilting Mount Clamping Assembly on a pole.

Note 1 - As shipped; the 4X4 Clamp On 100-400mm VESA Tilting Mount will be in two sections:

Section 1 = The 100-400mm VESA Mounting Plate Assembly

Section 2 = The 4X4 Clamp On 100-400mm VESA pole clamping assembly.

1. Measure the desired final height of the center of the screen and which side of the pole you would like your screen located on. Also consider if you will be locating power and data outlets behind the screen and which side will be optimum for their location. Apply a small section of tape to the pole to indicate the screen position on the pole.

2. Note; if you are locating power and data outlets behind the screen; these will need to be installed BEFORE the channel sections are attached to the pole.

3. Verify that the bottom and top of the pole assembly are properly secured before attempting to install the 4X4 Clamp On 100-400mm VESA Tilting Mount.

3. Locate the following items:

1 EA 100mm-400mm VESA Clamp on Mount Pole Channel section with the red lock assemblies

1 EA 100mm-400mm VESA Clamp on Mount Pole Channel section (bare)

4 EA PN 70420 Bolt 3/8-16 X 5" L Zinc

4 EA PN 70063 Nylon lock nut 3/8-16 hex zinc

4 EA PN 70077 #10 X 1/2" L Self-Drilling Screw Hex head Zinc

3. Orient the channel section with the red lock assemblies that will be supporting the screen so the flat side is flush against the side of the pole and the open side of the channel is oriented away from the pole with the two sets of attachment "Hooks" facing up. Move the channel section to the position indicated by the screen locator tape. Orient the second channel section (bare) with the "open side" turned so that it fits around the pole assembly.

4. Align the four holes in the two channel sections and insert the four 3/8-16 X 5" L bolts through holes, install the 3/8-16 lock nuts onto the ends of the bolts, verify that the assembly is at the correct location; then tighten the bolts securely and install the four Self-Drilling Screws to permanently secure the channel sections to the pole.

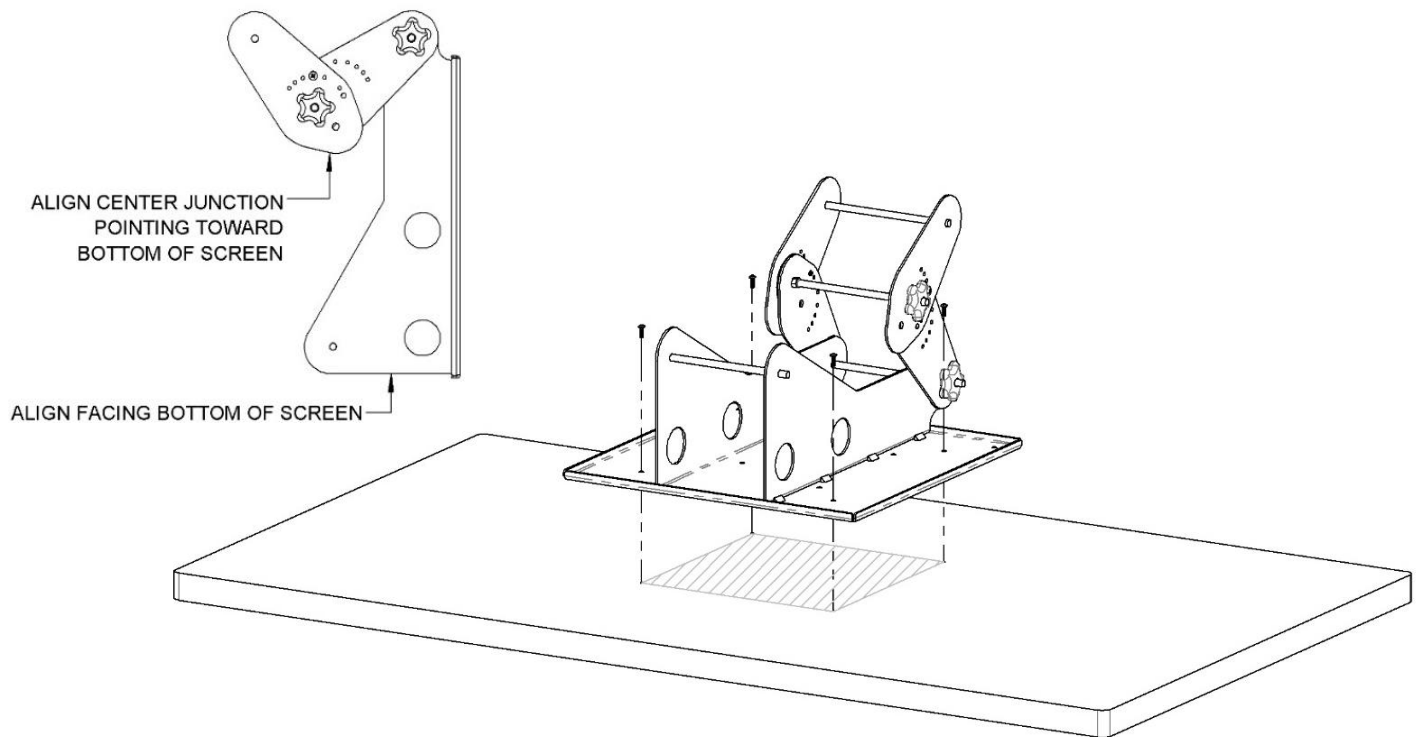

Attaching a PN 81561 4X4 Clamp On 100-400mm VESA Tilting Mount to the back of a screen

Note - As shipped; the 4X4 Clamp On 100-400mm VESA Tilting Mount will be in two sections:

Section 1- The 100-400mm VESA Mounting Plate Assembly.

Section 2- The 4X4 Clamp On 100-400mm VESA pole clamping assembly.

1. Lay the screen facing down on a flat, smooth surface, then lay the 100-400mm VESA Mounting Plate Assembly with the center junction of the Tilting link arms pointing down towards the bottom of the screen.
2. Align the square pattern of 100, 200, 300 or 400mm holes on the 100-400mm VESA Mounting Plate with the pattern of four tapped holes on the back of the screen.
3. Identify the included pack of screws:
 - 4 EA M6 X 10mm L Philips head screws (recommended for larger screens)
 - 4 EA M4 X 10mm L Philips head screws (recommended for smaller screens)
 - 5 EA flat washers for the M4 screws
4. Use a Phillips screw driver to carefully install the four appropriate screws through the holes in the 100-400mm VESA Mounting Plate and into the tapped holes on the back of the screen.

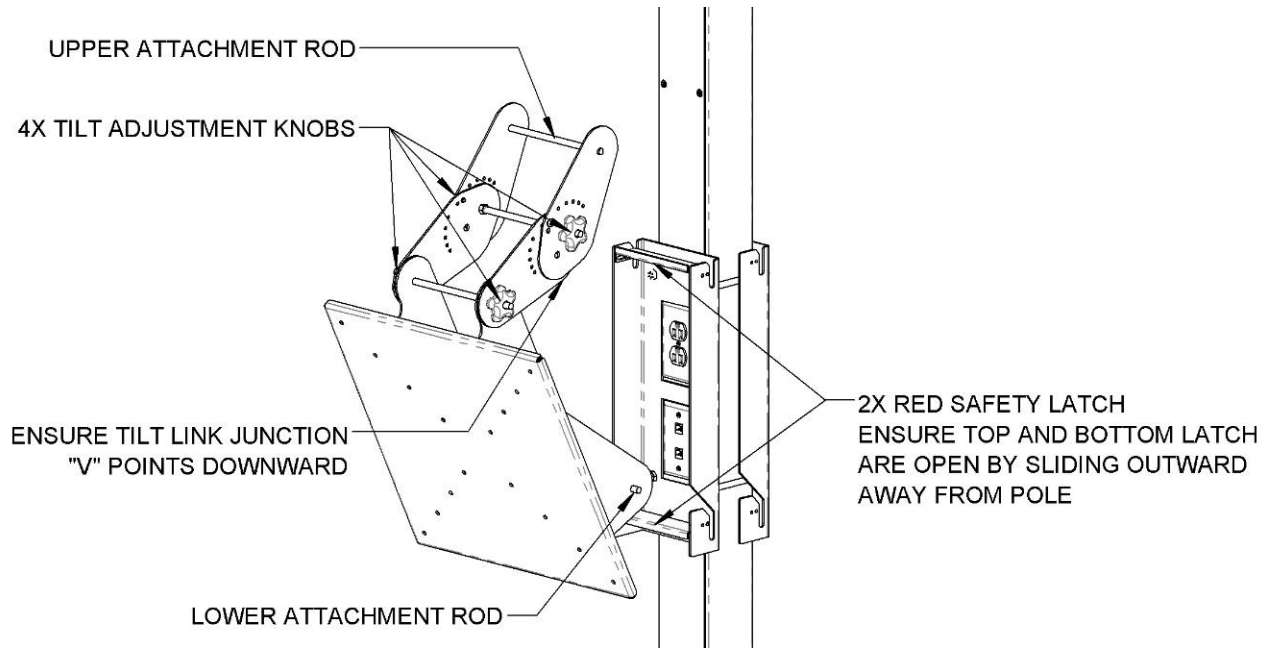

Attaching a screen with a 100-400mm VESA Mounting Plate Assembly onto a Clamping Assembly on a pole. (Part 1)

1. Note – Do not attempt to lift and install the screen without assistance.
2. Verify that the 100-400mm VESA Mounting Plate Assembly is securely attached to the back of the screen with the center junction of the Tilting link arms pointing down towards the bottom of the screen.
3. Examine the lower attachment rod on the bottom of the 100-400mm VESA Mounting Plate Assembly, locate the lower set of attachment hooks on the channel assembly and confirm that you understand that the rod must be inserted into the two lower attachment hooks on the channel section to support the screen.
4. Examine the four Tilting link arms, the upper attachment rod and confirm that you understand that the rod must be inserted into the two upper attachment hooks on the channel section to support the screen.
5. Verify that the four Tilting link arms are in a “semi folded V position” with the outer set of arms extended away from the back of the screen; verify that the four five point knobs on the Tilting link arms are loose enough to allow the links to be easily moved; but are not so loose as to allow the assembly fully expand without slight resistance.
6. Verify that the channel section with the red lock assemblies is installed with the two sets of attachment “Hooks” facing up and that both channel sections are securely attached to the pole assembly.
7. Verify that the upper and lower bars of the red lock assemblies are in the open position and the both sets of attachment hooks on the channel assembly are clear.

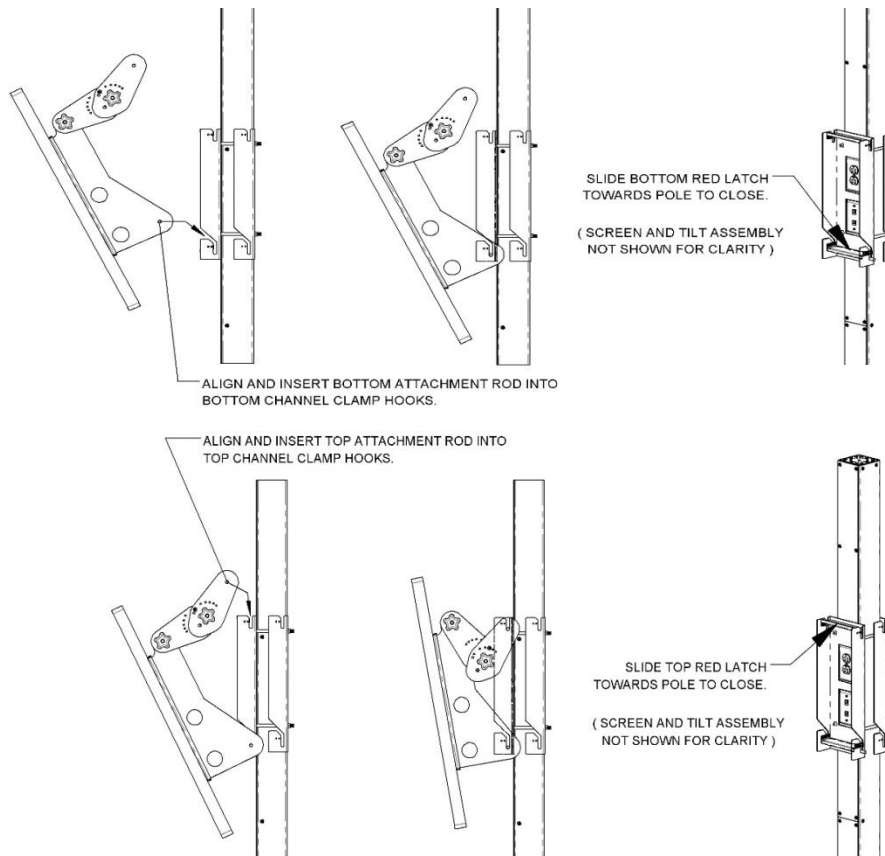

Attaching a screen with a 100-400mm VESA Mounting Plate Assembly onto a Clamping Assembly on a pole. (Part 2)

6. Identify the lower attachment rod on the bottom of the 100-400mm VESA Mounting Plate Assembly, locate the lower set of attachment hooks on the channel assembly and understand that once the screen is lifted; the bar must be aligned and then guided into the attachment hooks on the channel assembly.
7. Identify the outer Tilting link arms and the upper attachment rod on the top of the 100-400mm VESA Mounting Plate Assembly, locate the upper set of attachment hooks on the channel assembly and understand that once the screen is lifted; the bar must be aligned and then guided into the attachment hooks on the channel assembly.
8. Carefully lift the screen and guide the lower attachment rod until it is fully seating into the lower set of attachment hooks on the channel assembly; then pull the lower red lock bar outward to close the top of the attachment hooks.
9. Carefully guide the outer the Tilting link arms so the upper attachment rod is fully seating into the upper set of attachment hooks on the channel assembly; then pull the upper red lock bar outward to close the top of the attachment hooks.
10. Tighten the inner screws on the sides of the upper and lower red lock bars to secure the bars permanently in the locked position.
11. Adjust the tilt angle of the screen to the final desired position, and then securely tighten the four five point knobs on the tilting link arms. To permanently secure the tilt position; tighten the two tilt position locking screws into the holes on the inner tilt link arms to lock the screen tilt position in 5 degree increments from 0-25 degrees of forward tilt.

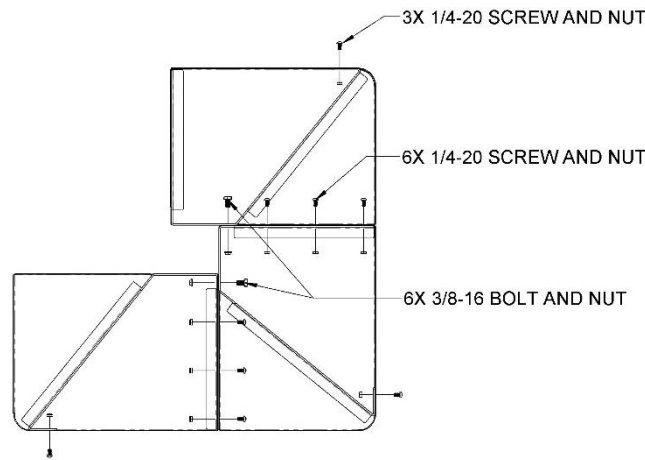

Attaching a 4 section, 30" X 30" Table Shelf to a Pole Assembly (part 1)

1. A 30"W X 30"L stainless table top assembly is made up of four individual 17"W X 13"D table corner sections that, when joined together, create the 30 X 30 table around a Pole assembly. An optional 17"W X 13"D Recessed Side Shelf unit with or without a bag holder can also be installed in place of one of the table corner sections.
2. Each of the 17"W X 13"D table corner sections are supported by a heavy duty, galvanized support bracket that attaches to the underside of the table corner sections. These support brackets are also bolted to each other to form an extremely strong "clamping box structure" that completely surrounds the Pole assembly.
3. Note that one of the table corner sections includes a cable pass through hole and grommet; consider the best location for this section with the grommet before assembling the table.
4. Before attempting to attach a table assembly to a Pole assembly verify that the bottom of the pole assembly is securely anchored to the floor and the top of the assembly is securely attached to the overhead structure of the ceiling.
5. To assemble a 30 X 30 table; lay three of the 17"W X 13"D table corner sections in a circular pattern with the smooth side facing down on a flat surface and the inner corners offset about 4" inches so that a 4"X4" square space is formed when the inside corners are aligned close together.
6. Place three of the support brackets onto the three table corner sections and carefully align the outside edges of the table sections so that all of the sides are flush and straight; then install all of the $\frac{1}{4}$ " bolts through the inner edges of the table sections and the flanges on the support brackets and then use $\frac{7}{16}$ " open end, box and/or socket wrenches to secure the nuts onto the ends of each of the bolts.
7. Install three 3/8-16 Pole clamping bolts into the three through holes on each of the support brackets and loosely install nuts onto the ends of each bolt. When your three sided table assembly is correctly assembled it should have a three sided 4" X 4" square opening in the center.
8. Place a short strip of painter's tape on one side of the pole assembly to indicate the desired final height of the table above the floor. This height will usually be between 32" and 36" above the floor.

Note: If your pole assembly includes a Pedestal Channel section; the table top must be installed below the bottom of the last door on the pedestal channel. If your pole assembly has cover plates installed below where the table is going to be attached to the pole assembly these cover plates must be installed first.

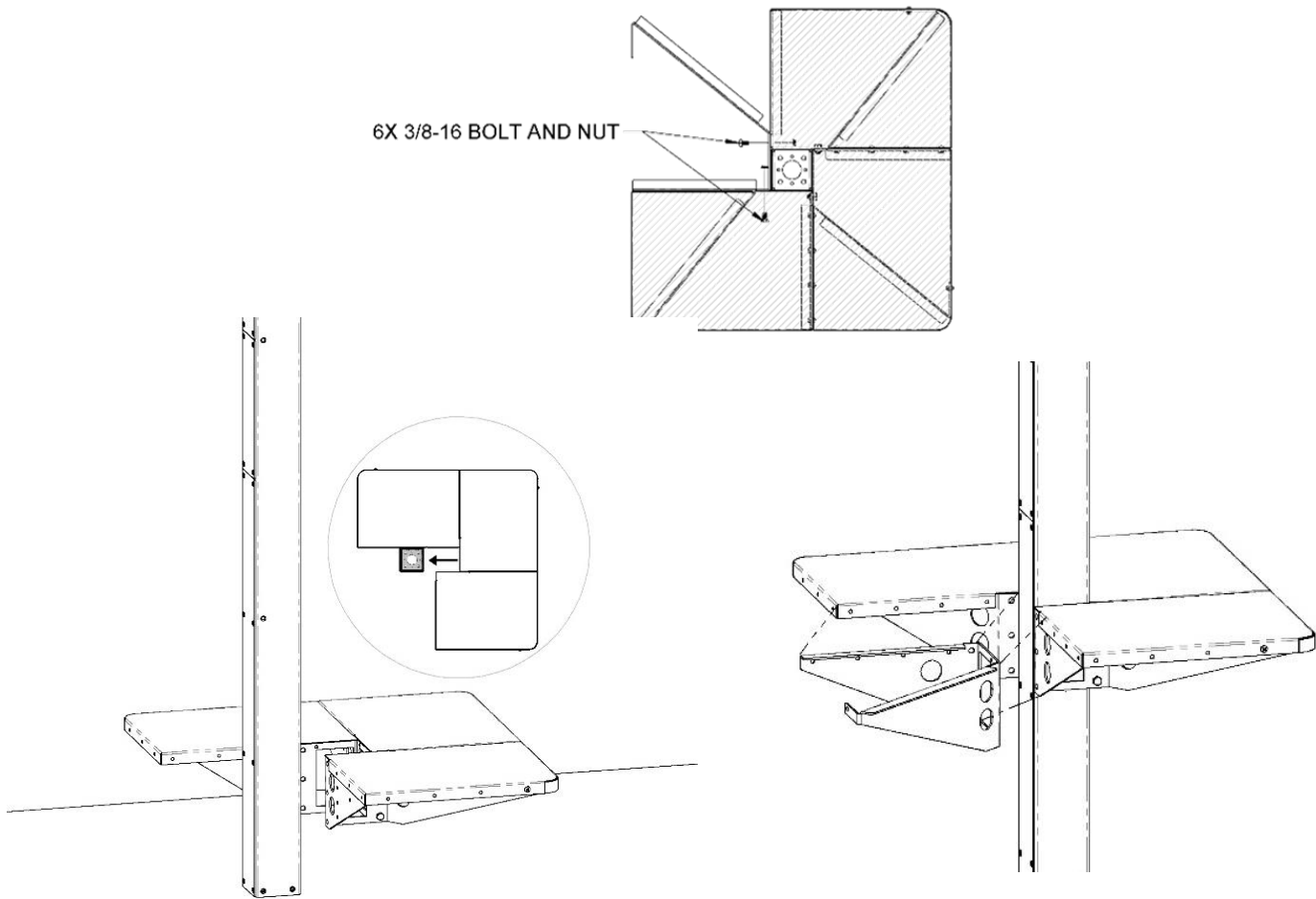

Attaching a 4 section, 30" X 30" Table Shelf to a Pole Assembly (part 2)

Note: The best practice is to have one or more people assist in lifting the three section table assembly about a foot above the floor while the final fourth section is installed. If assistance is unavailable; an alternate method is to create three temporary supports located under each of the three table corner sections. Items such as wood, strong boxes, milk crates or similar items can be placed around the base of the Pole assembly to serve as temporary supports that will elevate the three table corner sections above the floor at least 12".

9. Carefully turn the three section table assembly over so that the stainless table top is right side up, lift it and place it onto the temporary supports located around the base of the pole assembly. Once the table assembly is being supported by the temporary supports; carefully move the table assembly until the pole assembly is located inside of the three sided square opening in the center of the table assembly.

10. Align the fourth 17" W X 13"D table section support bracket with the sides of the two exposed support brackets. Install the six remaining 3/8-16 pole clamping bolts and loosely thread nuts onto the ends of each bolt so that all four of the support brackets are now connected.

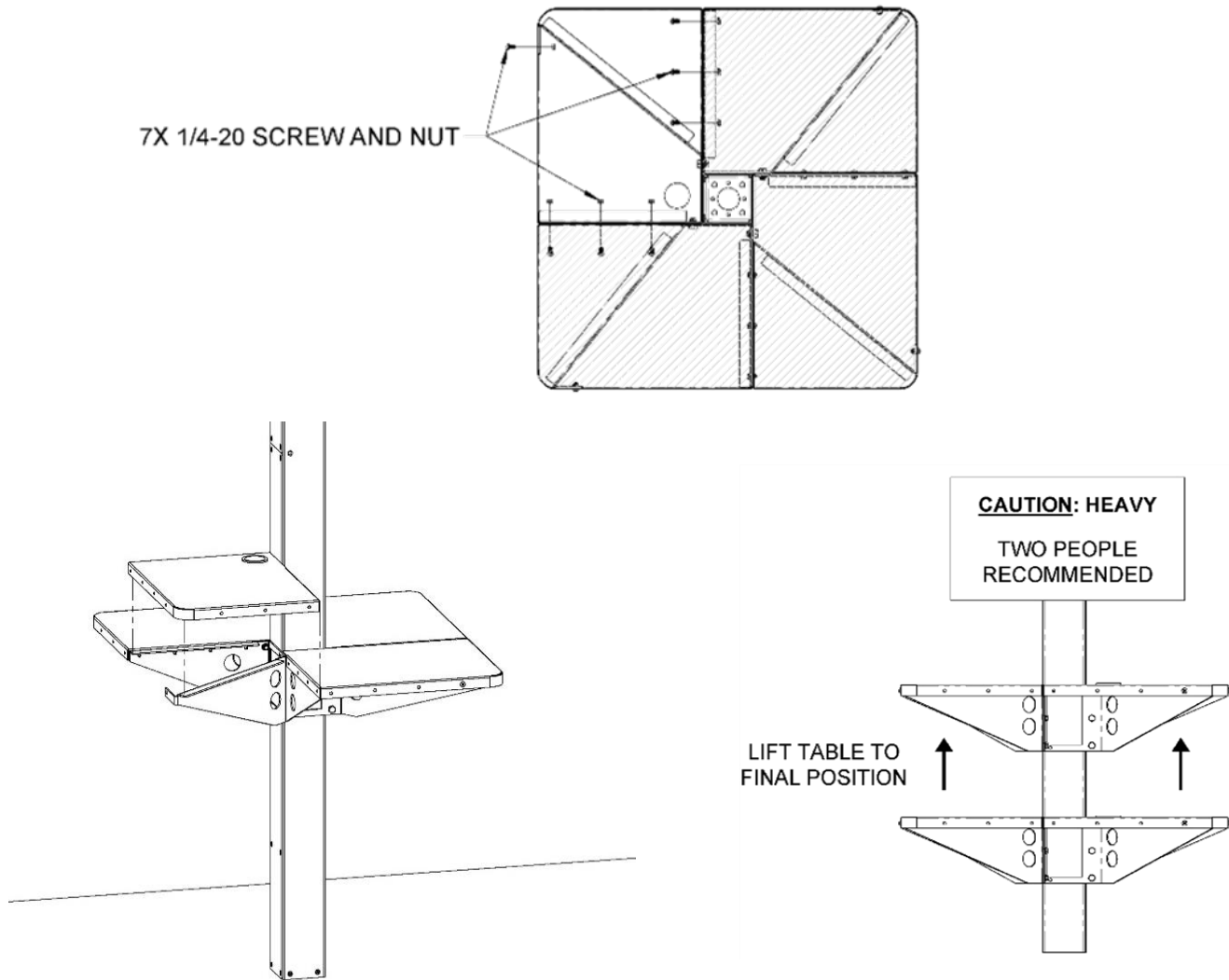

Attaching a 4 section, 30" X 30" Table Shelf to a Pole Assembly (part 3)

11. Lay the final table top section on top of the last support bracket and loosely install all of the 1/4"-20 bolts and nuts that will join the table top to the flanges of the support brackets and the inner edges of the other table top sections. Once all of the bolts are installed; verify that the edges of all of the table sections are straight and flat, then return to each set of fasteners and tighten them securely.

12. If the table top looks straight and flat you can begin tightening the 12 EA 3/8" clamping bolts on the support brackets being careful to leave each loose enough to allow the completed table top assembly to be lifted up the pole to its final location.

13. Once the table top is elevated to the final height return to each of the 3/8" clamping bolts on the support brackets and tighten them securely.

14. For permanent attachment; install 2-4 EA of #10 self-tapping screws through the 1/4" holes in the support brackets and into the sides of the Pedestal channel, Extension section, or Wireway.

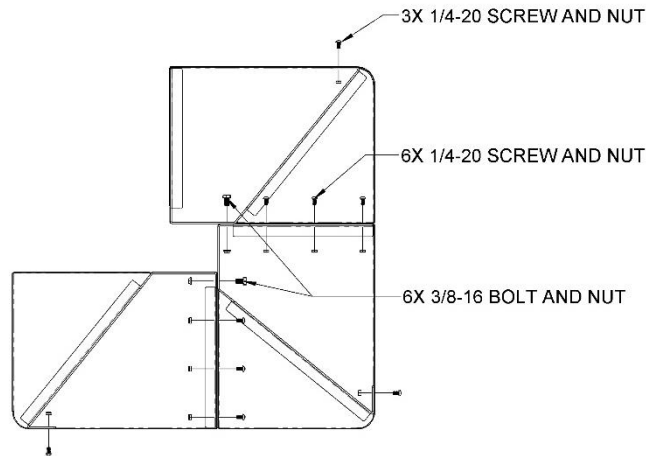

Assembling a Single or Double 30" X 30" Table with a Recessed Side Shelf unit and Bag Holder (part 1)

1. A 30"W X 30"L stainless table top assembly with a bag holder is made up of three 17" W X 13"D table corner sections and one 17" W X 13"D" Recessed Side Shelf unit with Bag Holder that, when joined together, create the 30 X 30 table around a Pole assembly.

2. Each of the 17" W X 13"D table corner sections are supported by a heavy duty, galvanized support bracket that attaches to the underside of the table corner sections. These support brackets are also bolted to each other to form an extremely strong "clamping box structure" that completely surrounds the Pole assembly.

3. Note that one of the table corner sections includes a cable pass through hole and grommet; consider the best location for the section with the grommet before assembling the table.

4. Before attempting to attach a table assembly to a Pole assembly verify that the bottom of the pole assembly is securely anchored to the floor and the top of the assembly is securely attached to the overhead structure of the ceiling.

5. To assemble a 30 X 30 table with a Recessed Side Shelf; lay three of the 17" W X 13"D table corner sections in a circular pattern with the smooth side facing down on a flat surface and the inner corners offset about 4" inches so that a 4"X4" square space is formed when the inside corners are aligned close together.

6. Place one of the support brackets onto each of the table corner sections and carefully align the outside edges of the table sections so that all of the sides are flush and straight; then install all of the 1/4" bolts through the inner edges of the table sections and the flanges on the support brackets and then use 7/16" open end, box and/or socket wrenches to secure nuts onto the ends of each of the bolts.

7. Install three 3/8-16 Pole clamping bolts into the three through holes on each of the support brackets and loosely install nuts onto the ends of each bolt. When your three sided table assembly is correctly assembled it should have a three sided 4" X 4" square opening in the center of the table top.

8. Place a short strip of painter's tape on one side of the pole assembly to indicate the desired final height of the table top above the floor. This height will usually be between 32" and 36" above the floor.

Note: If your pole assembly includes a Pedestal Channel section; the table top must be installed below the bottom of the last door on the pedestal channel. If your pole assembly has cover plates installed below where the table is going to be attached to the pole assembly; these cover plates must be installed first.

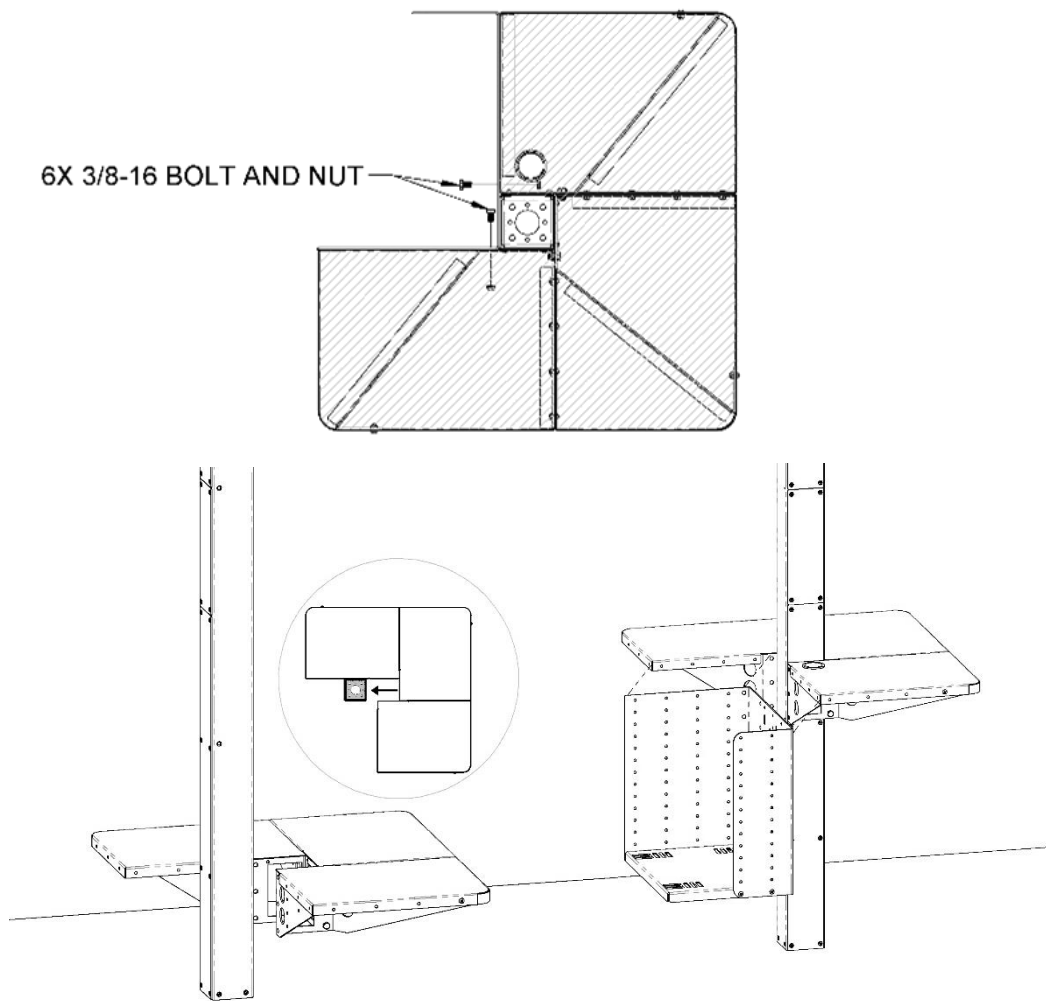

Assembling a Single or Double 30" X 30" Table with a Recessed Side Shelf unit and Bag Holder (part 2)

Note: The best practice is to have one or more people assist in lifting the three section table assembly about a foot above the floor while the final fourth section is installed. If assistance is unavailable; an alternate method is to create three temporary support stands with each support located under each of the three table corner sections. Items such as strong boxes, milk crates or similar items can be placed around the base of the Pole assembly to serve as temporary supports that will elevate the three table corner sections above the floor at least 12".

10. Carefully turn the three section table assembly over so that the stainless table top is right side up, lift it and place onto the temporary supports located around the base of the pole assembly. Once the table assembly is being supported by the temporary supports; carefully move the table assembly until the pole assembly is located inside of the three sided square opening in the center of the table assembly.

11. Align the 13" and 17" long sides of the Recessed Side Shelf Unit with the respective 13" and 17" sides of the table corner sections. Align the rear sides of the Recessed Side Shelf Unit with the exposed sides of the two support brackets.

12. Install the six remaining 3/8-16 pole clamping bolts and loosely thread nuts onto the ends of each bolt so that the three section table support brackets are now connected to the Side Shelf unit.

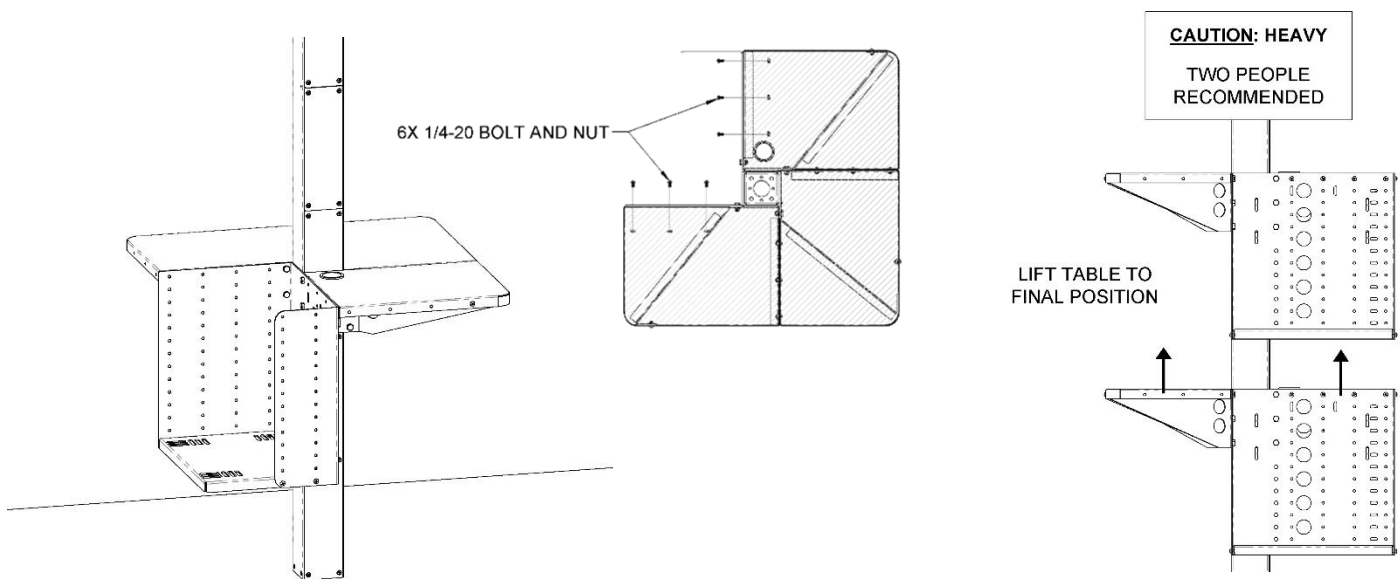

Assembling a Single or Double 30" X 30" Table with a Recessed Side Shelf unit and Bag Holder (part 3)

13. Loosely install all of the $\frac{1}{4}$ "-20 bolts and nuts that will join the table top to the flanges of the support brackets and the inner edges of the other table top sections. Once all of the bolts are installed; verify that the edges of all of the table sections are straight and flat, then return to each set of fasteners and tighten them securely.
14. Once the table top looks straight and flat you can begin tightening the 12 EA $\frac{3}{8}$ " clamping bolts and nuts on the support brackets being careful to leave each loose enough to allow the completed table top assembly to be lifted up the pole to its final location.
15. Lift the table top to its final height and return to each of the $\frac{3}{8}$ " clamping bolts on the support brackets and the recessed Side Shelf unit and tighten them securely.
16. For permanent attachment; install 2-4 EA of #10 self-tapping screws through the $\frac{1}{4}$ " holes in the support brackets and the recessed Side Shelf unit and into the sides of the Pedestal section, Channel Extension section, or Wireway.

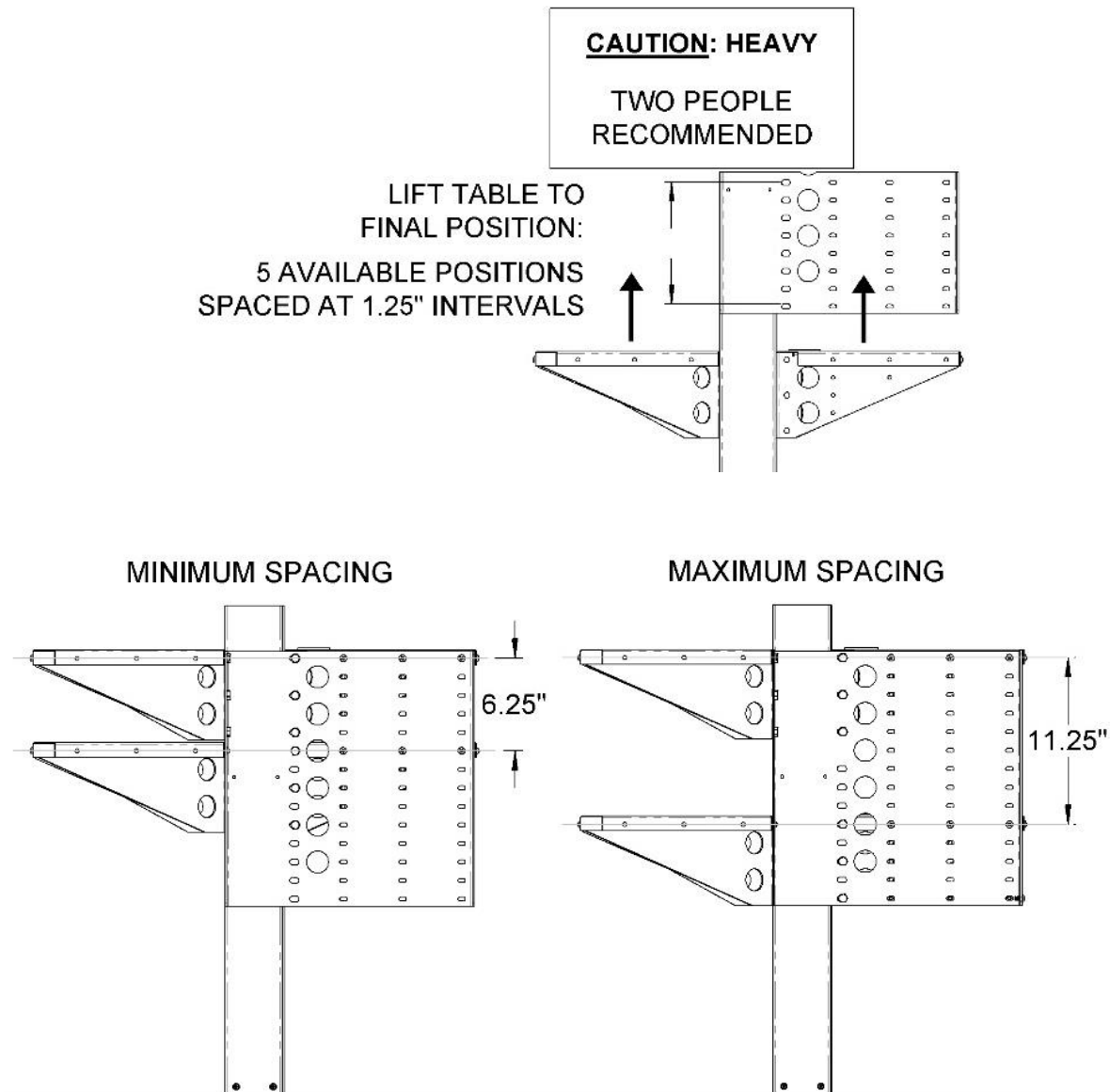

Assembling a Single or Double 30" X 30" Table with a Recessed Side Shelf unit and Bag Holder (part 4)

17. To install a second three section stainless table repeat steps 5-7 to preassemble another three section table assembly.

18. Repeat steps 10 and 11 to align the three section table assembly with the pole assembly and recessed Side Shelf unit.

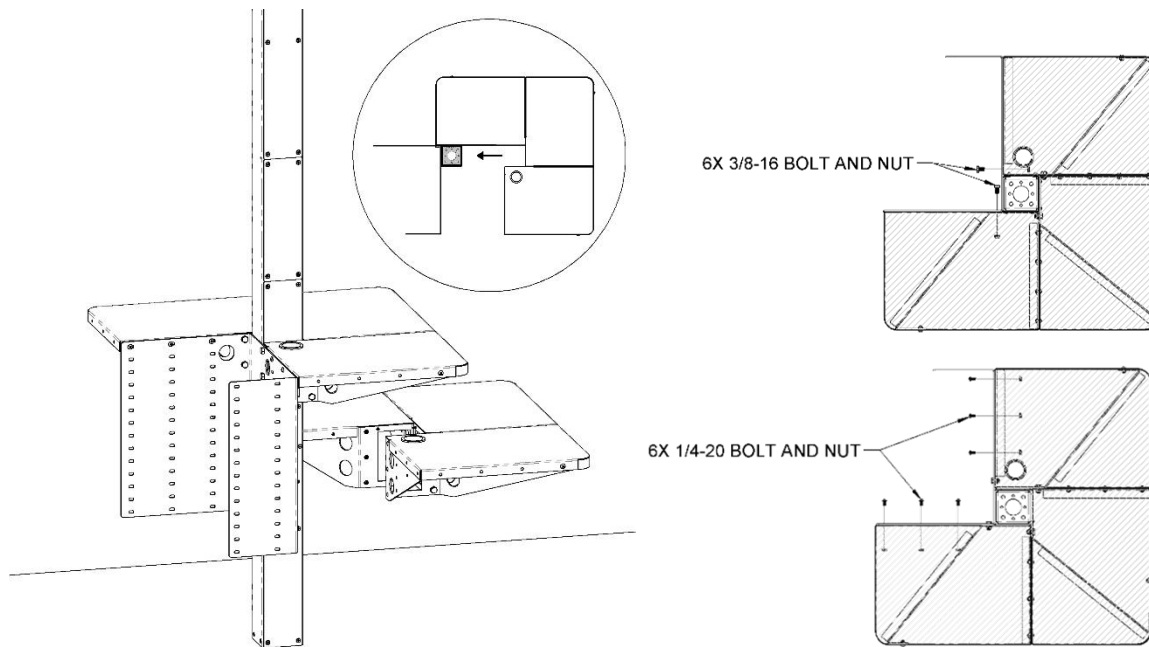

Assembling a Single or Double 30" X 30" Table with a Recessed Side Shelf unit and Bag Holder (part 5)

19. Install the six remaining 3/8-16 pole clamping bolts and loosely thread nuts onto the ends of each bolt so that the three section table support brackets are now connected to the Side Shelf unit.
20. Loosely install all of the 1/4"-20 bolts and nuts that will join the table top to the recessed Side Shelf unit. Once all of the bolts are installed; verify that the edges of all of the table sections are straight and flat, then return to each set of fasteners and tighten them securely.
21. If the table top looks straight and flat; you can begin tightening the 12 EA 3/8" clamping bolts and nuts on the support brackets being careful to leave each loose enough to allow the completed table top assembly to be lifted up the pole to its final location.
22. For permanent attachment; install 2-4 EA of #10 self-tapping screws through the 1/4"holes in the support brackets and into the sides of the Pedestal section, Channel Extension section, or Wireway.

Note- Also available with optional stainless steel 17"W X 13"D table top section to cover top of the side shelf unit and create a complete, square 30"W x 30" D table top. Note that a cash drawer can be supported directly below the table top when shelf is installed in the Side Shelf unit just below the table top.

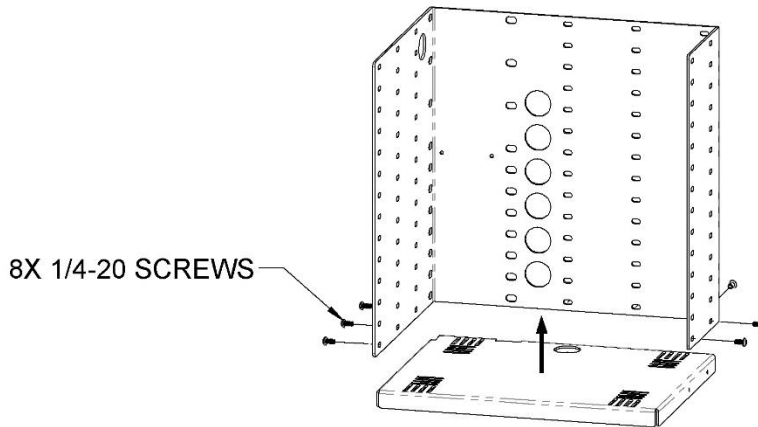

Installing and adjusting Shelves on a 30X30 Recessed Side Shelf Unit

1. A Recessed Side Shelf Unit can be installed in place of any 17"W X 13"D corner section of a 30x30 Stainless steel table top assembly.

Note this assembly can also be installed in place of any support bracket to add shelving under any table section

2. The Shelf mounting holes allow multiple 17"W X 13"D shelves to be installed at 1.25" increments along the entire height of the Side Shelf Unit. (Shelf is 16.5"W X 12.7"D)

3. If you are installing multiple shelves to support multiple items in the Side Shelf Unit; consider the optimum location for supported item and the height needed above each item to allow access.

4. Each Shelf is secured to the Side Shelf Unit with 8 EA ¼-20 screws.

5. Also available with optional stainless steel 17"W X 13"D table top section to cover top of the side shelf unit and create a complete, square 30"W x 30" D table top. Note that a cash drawer can be supported directly below the table top when shelf is installed in the Side Shelf unit just below the table top.

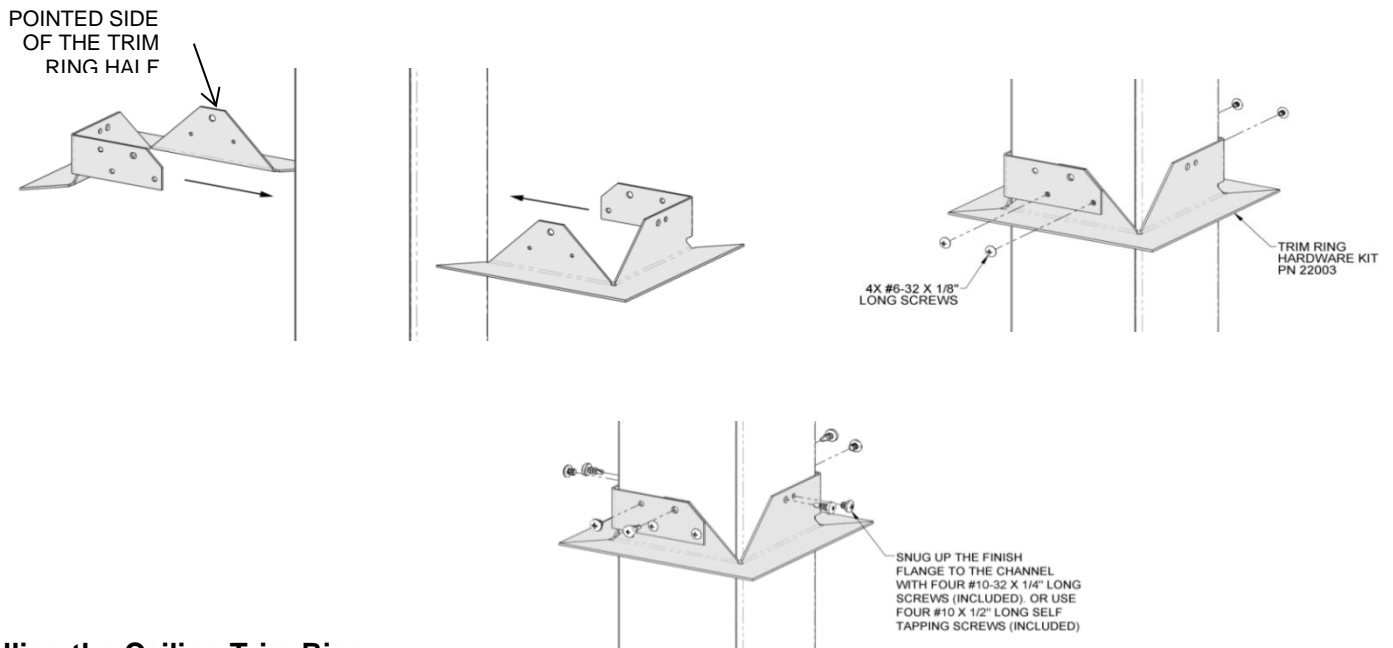

Installing the Ceiling Trim Ring

1. The trim ring assembly attaches to the channel section where it penetrates the ceiling. You should have already created a square hole that is $4\frac{3}{4}$ " W X $4\frac{3}{4}$ " D in your ceiling material during the initial fitting of your channel section. Refer to section: **Cutting a square opening in the ceiling for the Pole Assembly.**
2. Install the trim ring BEFORE installing the cover plates. The two "C" shaped / double corner sections of the trim ring need to be assembled together around the wireway channel BELOW the ceiling and ABOVE all of the outlets and any couplers to create the completed square trim ring assembly. Important note: The two POINTED mounting flanges of the trim ring assembly MUST be aligned with the closed right and left sides of the Pedestal Extension section, NOT the open front, and closed rear sides. Align the two section of the trim ring so that the two POINTED mounting flanges are POINTING UP so that the tapped holes on these flanges will be located INSIDE of the two flat- topped mounting flanges when the two halves are slid together.
3. Carefully slide the two trim ring sections together until the two types of flanges are partially overlapping and the through holes on each of the flat- topped / outside flanges are aligned with the tapped holes in the pointed / inside flanges. Install the (4) #6-32 screws to lock the two trim ring sections together. Once assembled the trim ring can be slid up to where the wireway meets the surface of the ceiling.
4. Align the square frame of the trim ring with the opening in the ceiling, push it up until it is flush with the underside of the ceiling, support it at this position and then temporarily secure it in place with sections of painter's tape.
5. From above the ceiling; locate the threaded trim ring clamping screw holes in the trim ring mounting flanges and install the clamping screws in the holes. Tighten these screws only enough to secure the trim ring to the channel section; but not enough to deform it.
6. Once the two trim ring clamping screw holes have been installed, verify that the trim ring is flush with the underside of the ceiling and install (2) to (4) self- drilling screws into the through holes and into the sides of channel section to secure it permanently.

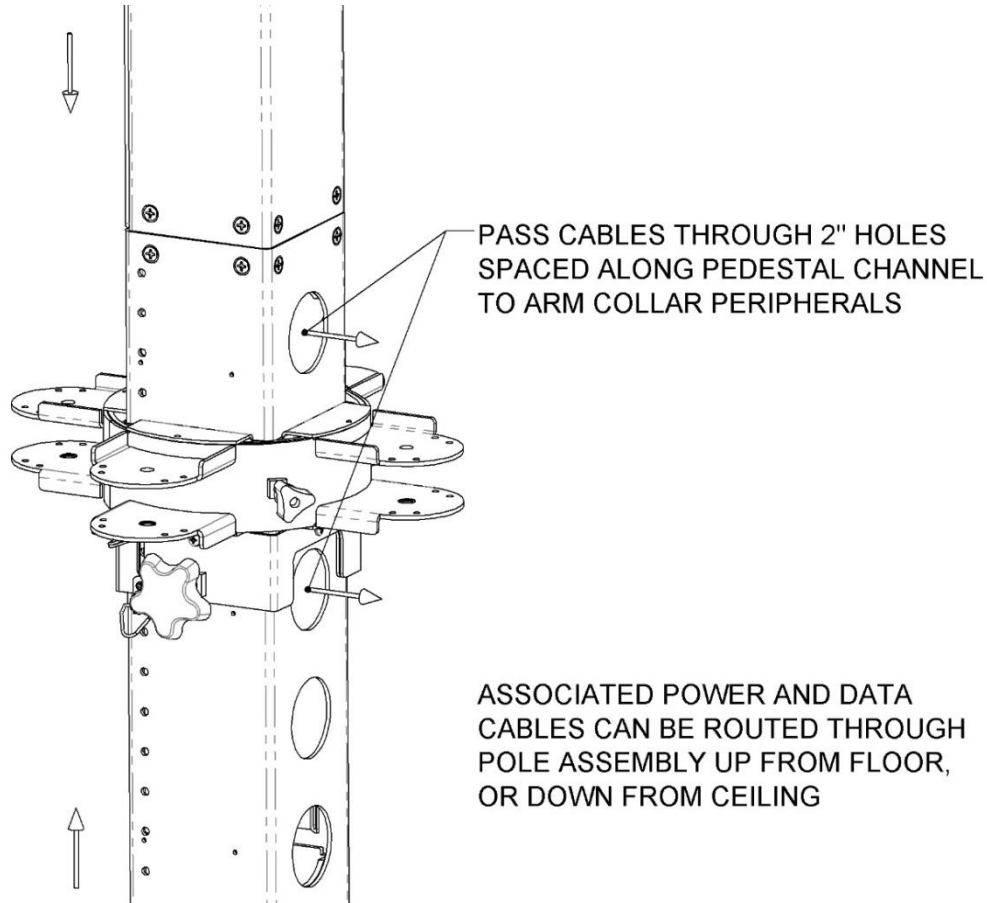

Installing and routing the power and other associated cables to a Pedestal Channel sections on a Channel Extension Section

- All components have been designed to ease the installation of any associated wiring within the assemblies:
- All Channel Extension Sections and Couplers have an internal vertical cable pathway that is approximately 3 $\frac{3}{4}$ " W X 3 $\frac{3}{4}$ " D square.
- Pedestal Channel sections include two separate sets of cable management tie points located at 6" intervals attached on opposite sides of the channel interior, both equipped with hook and loop straps.
- **Recommendation:** Route and bundle all high voltage power cabling on one side of the channel and all low voltage cabling in a separate bundle on the other side.
- Move each piece of equipment to discover the desired full range movement; tie off the cabling and then feed any excess cabling back into the Pedestal Channel.
- When all of the cables have been connected, perform power up and operational tests on all of the installed equipment. When you are satisfied that all of the equipment is operating correctly; secure all of the cabling inside of the Pedestal Channel using the two sets of hook and loop straps which are located on two opposite sides of the channel interior. We recommend that all high voltage power cabling be kept in one bundle on one side of the pedestal channel and all low voltage cabling be kept in a separate bundle on the other side.

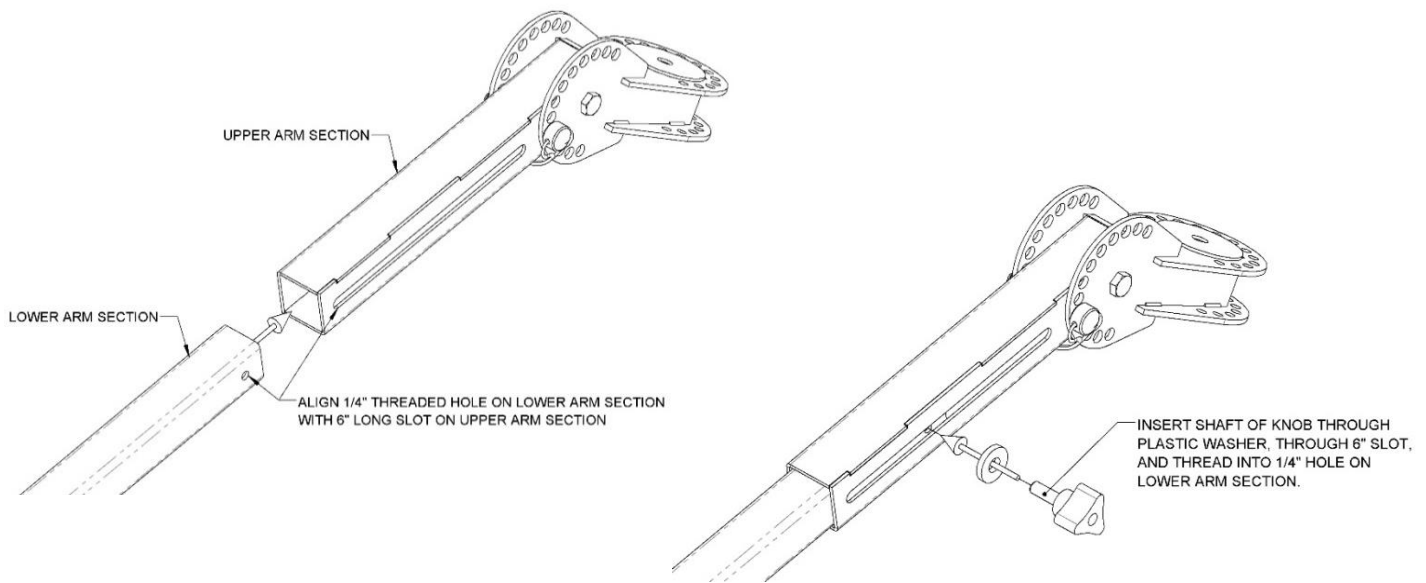

Assembling the lower half of an Articulating Extendable arm on an arm collar assembly

1. As shipped; all arm collar assemblies will require the lower arm assembly be attached to the upper arm assembly. Install the arm collar assembly onto the pedestal before reattaching these items. Identify the 1" square lower arm assembly; remove the three point knob and plastic washer from the threaded hole on the end of the arm.
2. Rotate the 1" square lower arm assembly arm until the $\frac{1}{4}$ " tapped hole on the side of the end of the lower arm is aligned with the with the 6" long slot on the side of the 1 $\frac{1}{4}$ " square upper arm assembly that is attached to the Arm Collar assembly.
3. Insert the end of the 1" square lower arm into the end of 1 $\frac{1}{4}$ " square upper arm assembly until you can see the tapped hole; then place the plastic washer on the shaft of the three point knob and insert the knob shaft through the slot and thread it into the tapped hole on the end of the lower arm.

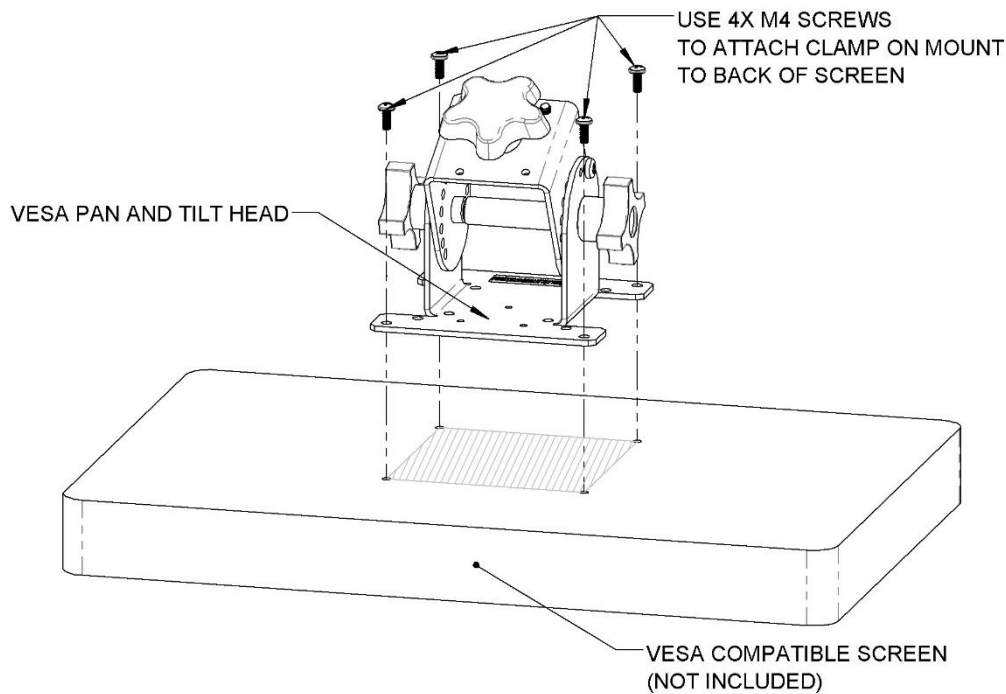

Attaching a VESA Pan and Tilt Head to the Back of a Screen

(Note; shown with a standard pan and tilt head; however the procedure is the same for all pan and tilt head types)

1. As shipped; all assemblies with VESA pan and tilt heads will need to be first attached to the back of the screens, then to the ends of the arms or a top cap. Install the arm collar or 4x4 clamp on assembly onto the pedestal or pole before reattaching the VESA pan and tilt heads.
2. If the pan and tilt heads are attached to the assemblies upon receipt; you will need to remove them by unscrewing and removing the five point knob from below panning base and then removing the rubber clutch. Place the rubber washer back onto the shaft of the knob and then temporarily screw the knob into the panning base.
3. Lay the screen face down on a flat, smooth surface, then lay the VESA Pan and Tilt Head assembly with the VESA mounting plate facing down on the back of the screen.
4. Align the square pattern of either 75mm or 100mm spaced holes in the VESA mounting plate with the pattern of four tapped holes on the back of the screen.
5. Use a Philips screw driver to carefully install the four supplied M4 screws through the holes in the VESA mounting plate and into the tapped holes on the back of the screen.

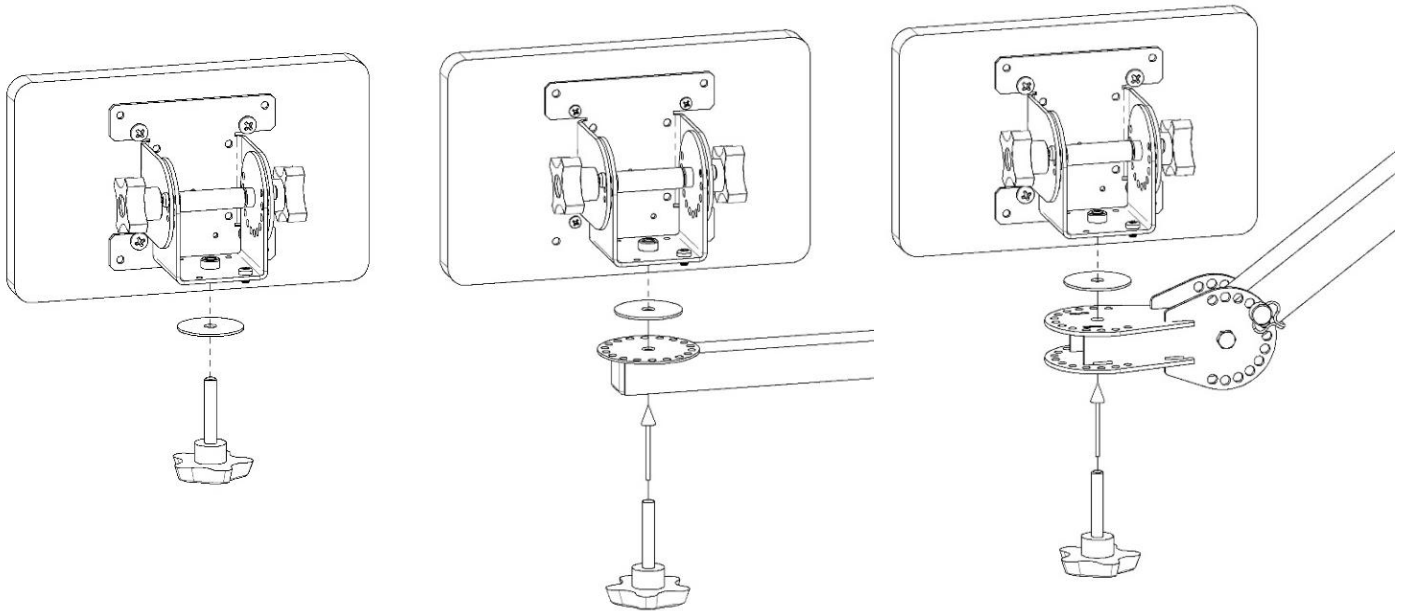

Installing a screen with an attached VESA Pan and Tilt Head on the end of an Arm

(Note; shown with a standard pan and tilt head; however the procedure is the same for all pan and tilt head types)

1. As shipped; all arm collar assemblies will require that the VESA pan and tilt heads be attached to the ends of the arms. Install the arm collar assembly onto the pedestal before reattaching the VESA pan and tilt heads. Refer to the section “**Attaching a VESA Pan and Tilt Head to the Back of a Screen** “
2. To install the screen with the attached pan and tilt head onto the end of an arm; remove the five- point knob and the rubber clutch washer from the pan bracket of the VESA Pan and Tilt Head assembly. Place the rubber clutch washer on the top of the end of the arm and align the hole in the center of the washer with the hole on the end of the arm.
3. Carefully lift the Screen with the attached VESA Pan and Tilt Head assembly, align the tapped hole in the panning base of the pan and tilt head with hole in the rubber clutch washer on the top of the end of the arm, install the shaft of the five-point hand knob up through the underside of the arm, through the rubber clutch washer and then carefully thread it into the panning base of the pan and tilt head.

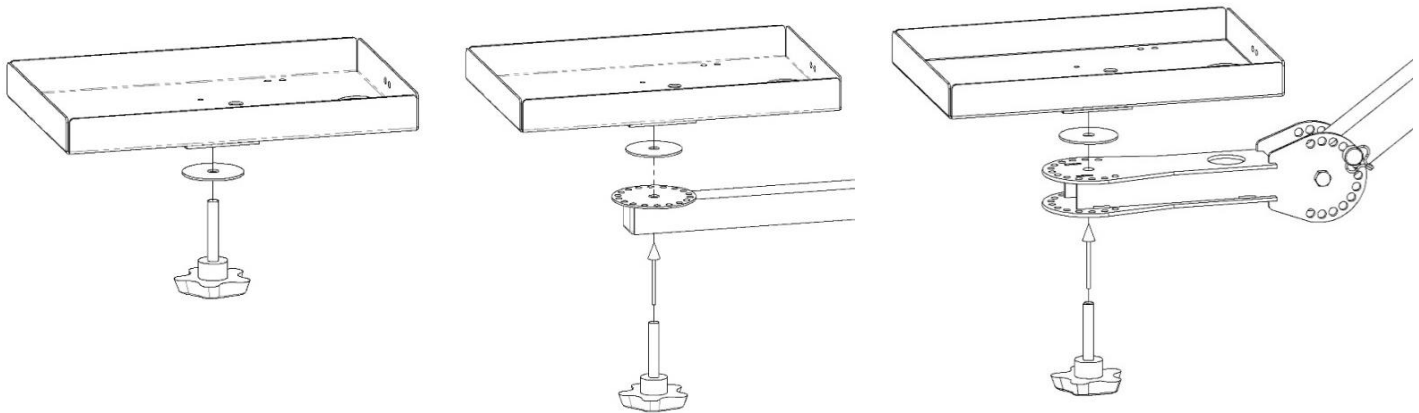

Attaching a POS Printer or Peripheral Equipment Tray to the end of an Arm

1. As shipped; all arm collar assemblies will require that the printer trays be attached to the ends of the arm assemblies. Install the arm collar assembly onto the pedestal before reattaching these items.
2. To install the printer tray; remove the five- point knob and the rubber clutch washer from the base of the printer tray. Place the rubber clutch washer on the top of the end of the arm and align the hole in the center of the washer with the hole on the end of the arm.
3. Carefully lift the printer tray and align the tapped hole in the base of the tray on top of the rubber clutch washer on the top of the end of the arm, install the shaft of the five-point hand knob up through the underside of the arm, through the rubber clutch washer and then carefully thread it into the base of the printer tray.

Interactive Catalog of Product Sub Groups

Page 1

There are many individual products included in the various product sub groups featured on these pages.

Click on the images or descriptions to visit the individual product sub group pages on our website.

For Information about individual products; click on the "Product Attachments" tab on each of the individual product pages.

[Practical Quality Systems Home Page](#)



[Wall Mounts for Screens](#)



[Wall Mounts for POS Printers](#)



[Wall Mounts for Screens and POS Printers](#)

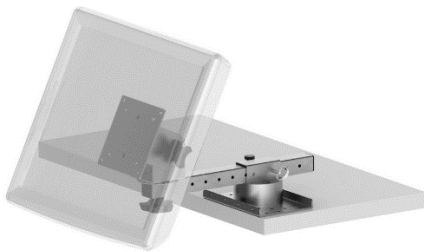

[Shelf Edge Mounts for Screens](#)



[Shelf Edge Mounts for POS Printers](#)



[Shelf Edge Mounts for Screens and POS Printers](#)

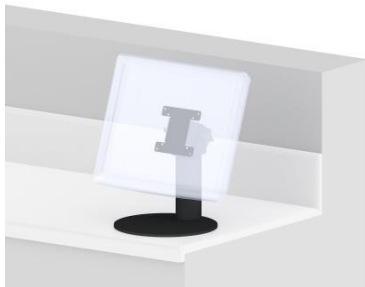

[Counter Top Mounts for Screens](#)



[Counter Top Mounts for POS Printers](#)

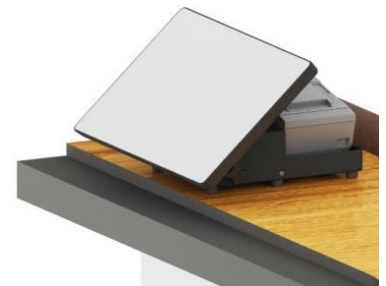

[Counter Top Mounts for Screens and POS Printers](#)

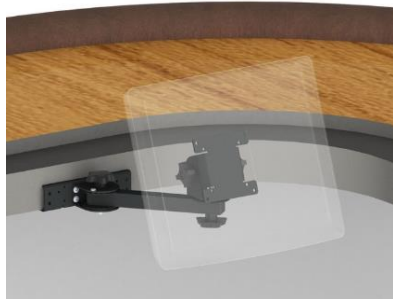

[Under Counter Mounts for Screens](#)



[Under Counter Mounts for POS Printers](#)



[Under Counter Mounts for Screens and POS Printers](#)

Interactive Catalog of Product Sub Groups**Page 2**

There are many individual products included in the various product sub groups featured on these pages.

Click on the images or descriptions to visit the individual product sub group pages on our website.

For Information about individual products; click on the "Product Attachments" tab on each of the individual product pages.

[Practical Quality Systems Home Page](#)

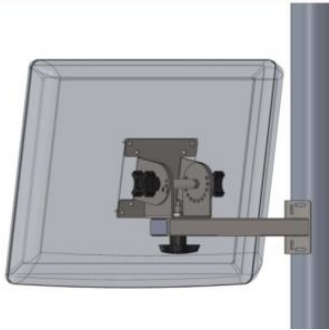

[Pole Mounts for Screens](#)



[Pole Mounts for POS Printers](#)



[Ceiling Mounts for Screens](#)



[Oracle MICROS Mounting Systems](#)



[NCR Aloha KDS Mounting Solutions](#)



[QSR KDS Mounting Solutions](#)



[Logic Controls Bematech KDS Mounting Solutions](#)



[Universal Kitchen Display System Mounting Packages](#)



[Enclosures for Touchscreen, Monitors and Thin Clients](#)

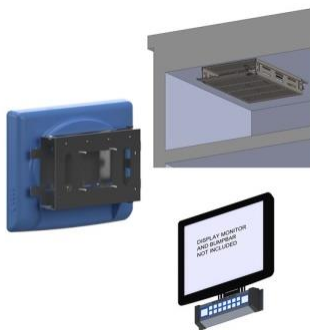

[Back Of Screen VESA Mounts for Controllers, Thin Clients, Bump Bars, Tap+ Touch + EMV Readers](#)



[Stainless Steel Wireways](#)

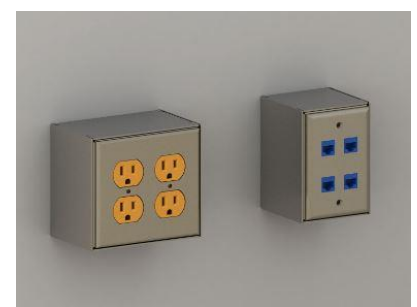

[Stainless Steel Power and Data Outlet Monuments](#)

Interactive Catalog of Product Sub Groups

Page 3

There are many individual products included in the various product sub groups featured on these pages.

Click on the images or descriptions to visit the individual product sub group pages on our website.

For Information about individual products; click on the "Product Attachments" tab on each of the individual product pages.

[Practical Quality Systems Home Page](#)



[Movable Countertop POS Stands](#)



[Direct Mount Countertop POS Stands](#)

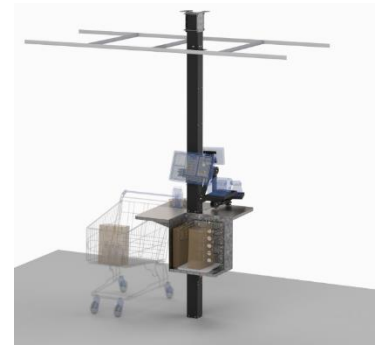

[POS Cashier Pole Stands](#)

New Product
Coming Q3
2023

[POS Cashier Floor Stands](#)



[POS Self-Check Out Kiosk Floor Stands](#)

New Product
Coming Q3
2023

[POS Self-Check Out Kiosk Pole Stands](#)



[Take Out Pickup Pole Stands](#)



[Take Out Pickup Floor Stands](#)



[Information Kiosk Floor Stands](#)

New Product
Coming Q3
2023

[Desktop Multi-Screen Pedestal Stands](#)



[4X4 Pole Clamp on Mounts](#)

New Product
Coming Q3
2023

[Mobile Cashier Stands](#)

Interactive Catalog of Product Sub Groups

Page 4

There are many individual products included in the various product sub groups featured on these pages.

Click on the images or descriptions to visit the individual product sub group pages on our website.

For Information about individual products; click on the "Product Attachments" tab on each of the individual product pages.

[Practical Quality Systems Home Page](#)

New Product
Coming Q3
2023

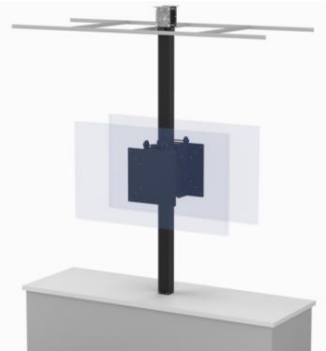

[Digital Signage Pole Stands](#)

New Product
Coming Q3
2023

Stationary Podiums

New Product
Coming Q3
2023

Mobile Self-Check Out Stands

New Product
Coming Q3
2023

Stationary Podiums with Ceiling Feed Pole

Mobile Podiums

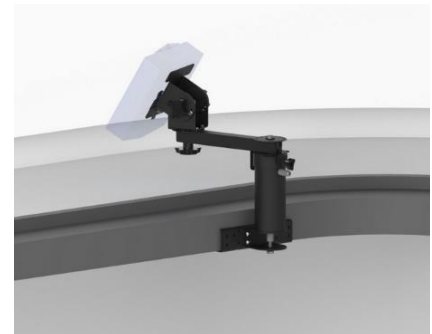

[Ingenico Lane Reader Mounting Systems](#)

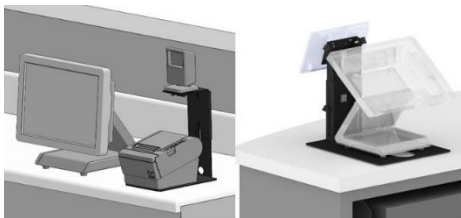

[Other Counter Top Mounts](#)

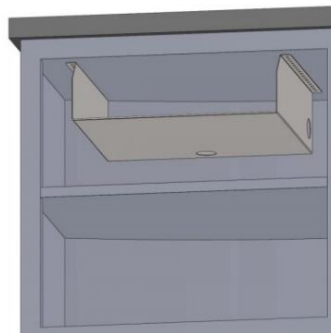

[Cash Drawer Mounting Solutions](#)

We believe in ethical SEO relevancy; the following sections were included to assist the all-knowing Algorithms in locating this page; however some humans like it too.

Compatible POS Systems : Lightspeed, logic controls, NCR, elotouch, posiflex, Poster POS, ehopper, Beetronics, Tyso, favpng, Touch Dynamic, FastSpring, CAKE, Erply, Sapaad, Upserve, Salesforce Commerce Cloud, Block, Miva Merchant, Epos Now, QuickBooks POS, Shopify, VEND, Revel, Clover, CovaPOS, Oracle NETSUITE, GoDaddy, Helcim, Epos Now, Upserve POS, Elo, CardConnect, NCR, ALOHA, SQUARE, Posnation, KORONA POS, BEMETECH, toast, Touchbistro, LAVU, Partnertech, MICROS ORACLE and frankly any system with a 50mm, 75mm or 100mm VESA compatible mounting standard.

Partial List of compatible printers that fit the interior dimensions of our Printer Trays:

6½” W X 10¼” L X 1” D : Anser U2, Brother QL 800, Brother PTP700, Citizen CT-E351, Clover P500, Clover Mini, Custom America CT-E351, Dymo LabelWriter 450, Dymo LabelWriter Wireless, Dymo LabelManager PnP, Epson TM-T88V/VI, Epson TM-T20II, Epson TM-U220 Type B & D, POS-X Evo HiSpeed, Rollo Printer, Sato FX3-LX, Sato WS2, Square Terminal, Star Micronics mC-Print3.

Movable Countertop Point of Sale Stands, Direct Mount Countertop Point of Sale Stands

Point of Sale countertop kiosk, POS terminal Display Stand with arms, Countertop Point of sale support system, Cashier countertop stand with arms, VESA POS Mounting Solution with arms for printer and Pin pad holder, Cashier countertop stand for POS terminal, printer, customer display, Rear marketing display and Pin pad or payment terminal. Through countertop POS Cashier mount with arms.

Cashier Pole Stands, Cashier Floor Stands, Mobile Cashier Stands: Point of Sale floor stand kiosk, POS terminal Display floor stand with arms, Floor stand Point of sale support system, Cashier floor stand with arms, VESA POS Mounting Solution with arms for printer and Pin pad holder, Cashier floor stand for POS terminal, printer, customer display, Rear marketing display and Pin pad or payment terminal.

Self-Check Out Kiosk Pole Stands, Self-Check Out Kiosk Floor Stands, Mobile Self- Check Out Kiosks:

Point of Sale Self-service floor stand kiosk, Self-service POS terminal Display floor stand with arms, Floor stand Point of sale Self-Check Out support system, Self-service floor stand with arms, VESA Self-service POS Mounting Solution with arms for printer and Pin pad holder, Self-service floor stand for POS terminal, printer, customer display, Rear marketing display and Pin pad or payment terminal, SCO solution, Interactive Kiosk, Self-Ordering, Self-Checkout, Self Service, Service Point Kiosk, Ticketing solutions.

Take Out Pickup Pole Stands, Take Out Pickup Floor Stands: Food Delivery Pickup Stand, Food Delivery Pickup Stand Screen, Mobile Order Pick up Stand, Mobile Order Pick up shelves with screen. Pick up orders station, Pick up orders station screen, Online Order Pickup stand, Online Order Pickup shelves with screen, Digital Order Pickup stand, Digital Order Pickup Stand with Shelves and screen, To Go Order Pickup stand, To Go Order Pickup stand with Shelves and Screen, Food Delivery Pickup Stand Shelving, Food Delivery Pickup Stand with Shelves and Screen, Mobile Order Pick up Stand Shelving, Mobile Order Pick up Stand with Shelves and Screen.

Digital Signage Pole Stands, Information Kiosk Floor Stands: Information directory stand, Information directory Kiosk, Information Kiosk Floor Stand, Information touchscreen stand, Self-service touchscreen stand, digital media player stand, Freestanding touch screen stand. Digital signage floor stand, Universal Kiosk Floor Stand, Touchscreen Kiosk, Interactive Kiosk, Digital Kiosk, Interactive Information Kiosk, Touch screen stand, Promotional Interactive Kiosk, Digital Signage floor stand, Freestanding Kiosk, Digital Signage Pole stand.

Desk Top Multi-Screen Pedestal Stands; These are super heavy duty systems that support up to four 32” screens with not one; but TWO cup holders, a nifty organizer tray and dual USB changing ports, whoa!