

PQS

PRACTICAL QUALITY SYSTEMS
Fast Custom Manufacturing - Nationwide Installation Services

Partner Tech EM-200 Enclosure PN 80927



Note: 80927 shown here in Raven Black. Also available in stainless steel (PN 80927-SS) and metallic chrome powder coated finish (PN 80927-CH)

Partner Tech EM-200 Enclosure PN 80927

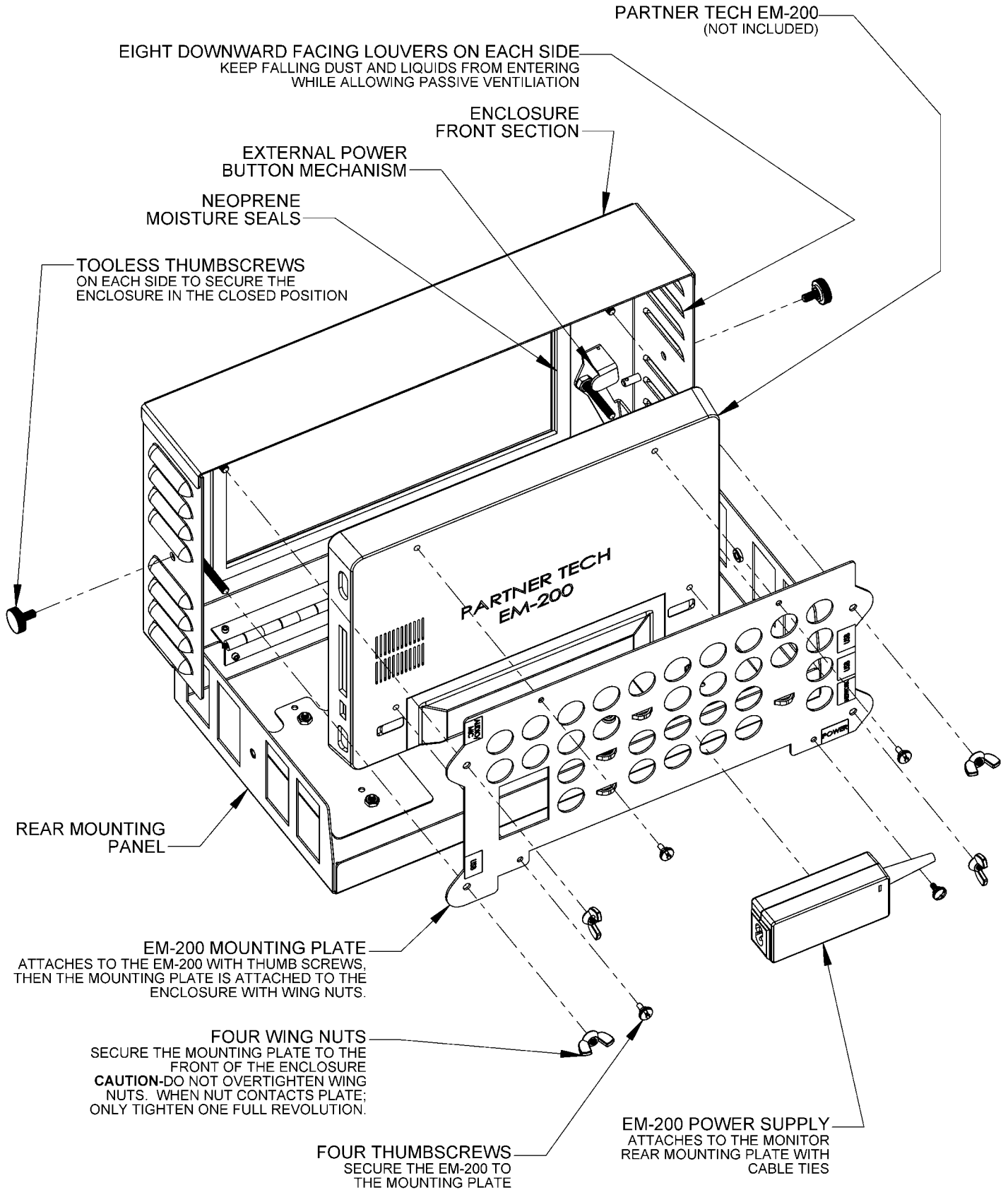

Partner Tech EM-200 Enclosure PN 80927

PRODUCT SPECIFICATIONS:

General Features

- This wall mount enclosure can be used as a universal VESA compatible support system for the Partner Tech EM200 tablet for Point of Sale / POS, Kitchen Display Systems / KDS in commercial kitchens, retail, restaurants, offices, industry, shops, medical, maritime, schools, laboratory and many other applications.
- Meets NEMA Type 2 rating- Enclosures constructed for indoor use to provide a degree of protection to personnel against access to hazardous parts; to provide a degree of protection of the equipment inside the enclosure against ingress of solid foreign objects (falling dirt); and to provide a degree of protection with respect to harmful effects on the equipment due to the ingress of water (dripping and light splashing).
- Downward facing louvers are located along both sides to keep falling liquids and dust from entering while allowing for passive ventilation.

Enclosure Features

- Can be attached to a wall in either surface flush mount configurations.
- VESA 100mm mounting standard.
- A heavy duty hinge allows the front panel to open without tools and allows full access to the interior without removing the enclosure from the wall or mounting system.
- External power button lever easily actuates the power on/off button on the side of the EM-200 computer.
- Thumbscrews secure the *enclosure front section* in the closed position; but are removable for easy access to the EM-200 and cabling.
- Close fitting neoprene gaskets surround the entire edge of the terminal's screen and indicator lights to seal them against liquid entry.
- Includes an internal mounting location for the terminal's power supply on the back of the mounting plate.
- Can be supported by any PQS 100mm mounting system.

Mounting Plate Features

- Thumbscrews secure the terminal to the mounting while wing nuts secure mounting plate to the *front cover plates* of the enclosure for easy installation and removal that requires no tools.
- The interior includes multiple tie points to secure power supply and data cabling.
- To order stainless steel enclosure use P/N 80927-SS; chrome metallic powder coated finish use P/N 80927-CH.
- To order an Under Counter Mount, use P/N 80932; a Countertop Pedestal Mount, use P/N 80929
- Enclosure supports Partner Tech EM-200 Touchscreen Unit; Width 14.4in (366mm) x Depth 3.0in (76mm) x Height: 7.9in (201mm)

Partner Tech EM-200 Enclosure PN 80927

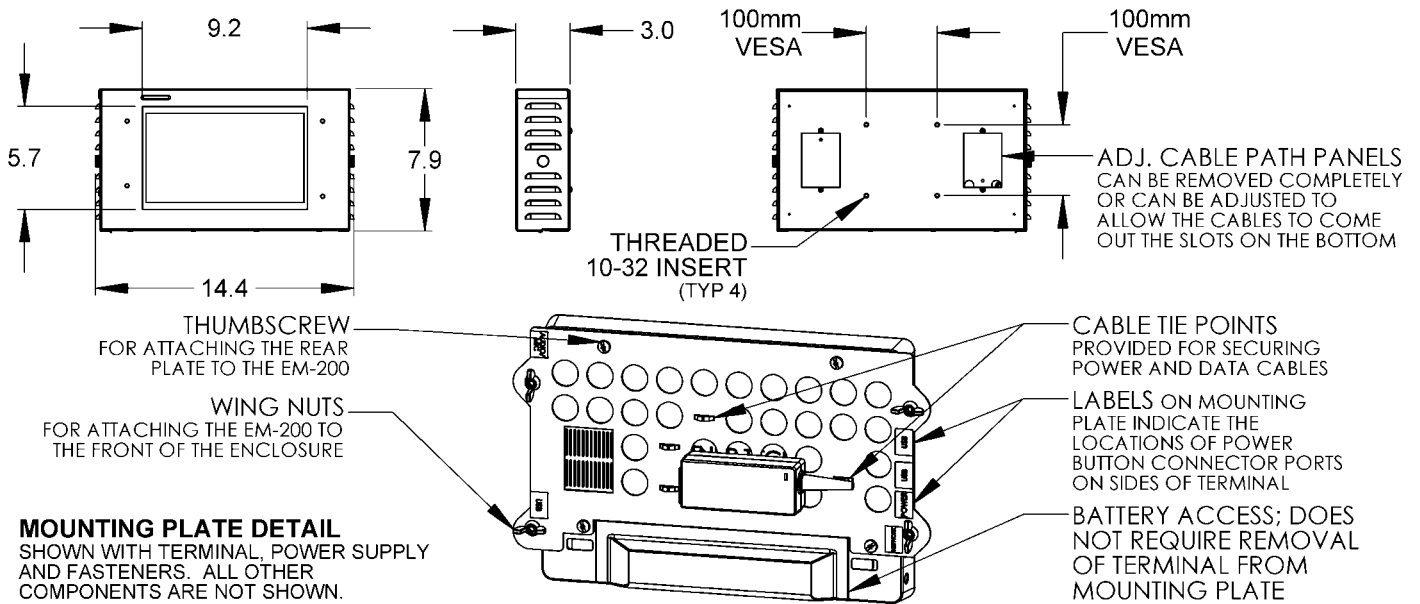

Partner Tech EM-200 Enclosure PN 80927

MOUNTING OPTIONS:

WALL MOUNTING OPTIONS

SURFACE MOUNTING TO A WALL

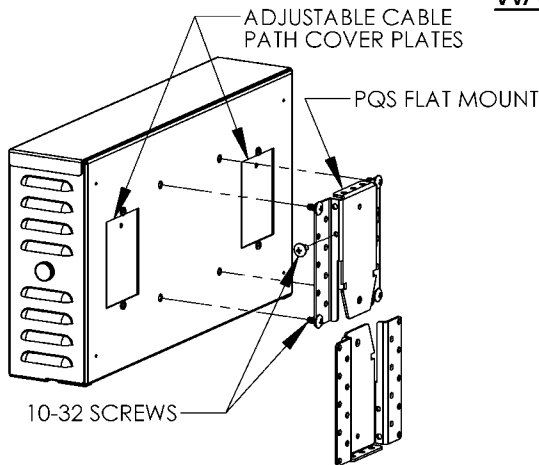

- ① USING PQS FLAT MOUNT (P/N: 80910), REMOVE ONE OF THE KNOCK OUTS ON THE REAR ACCESS PLATE FOR DATA AND POWER CABLES TO GO THRU.
- ② ATTACH ENCLOSURE TO ONE HALF OF THE FLAT MOUNT WITH FOUR (4) 10-32 SCREWS.
- ③ THEN ATTACH THE OTHER HALF TO THE WALL BY USING APPROPRIATE HARDWARE (NOT PROVIDED)
- ④ THEN SLIDE THE TWO PIECES TOGETHE AND LOCK THEM WITH THE 10-32 SCREW.

FLUSH MOUNTING TO A WALL

IMPORTANT:

- ① WHEN ATTACHING THE ENCLOSURE DIRECTLY TO A WALL MAKE SURE THE ELECTRICAL & DATA ARE 9 INCHES APART ON CENTER SO THE REAR OF THE ENCLOSURE WILL LINE UP WITH THE MOUNTING HOLES FOR THE COVER PLATES.
- ② DRILL OUT THE FOUR (4) MOUNTING HOLES IN THE CORNERS TO FIT THE APPROPRIATE HARDWARE NEEDED TO SECURE THE ENCLOSURE TO THE WALL SURFACE.

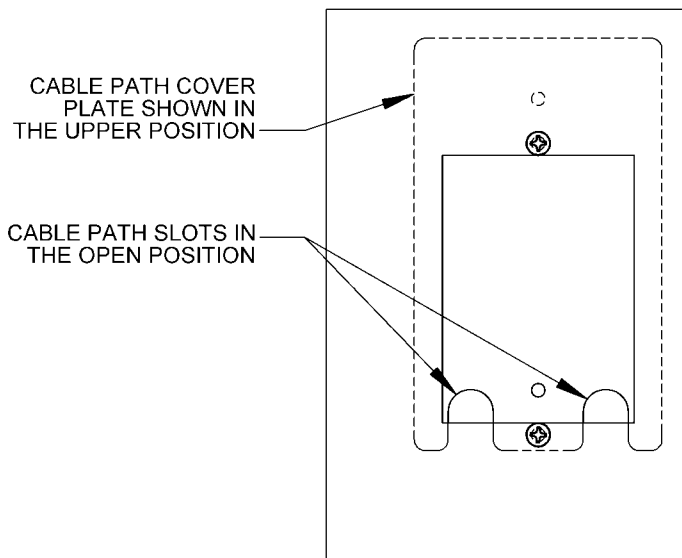
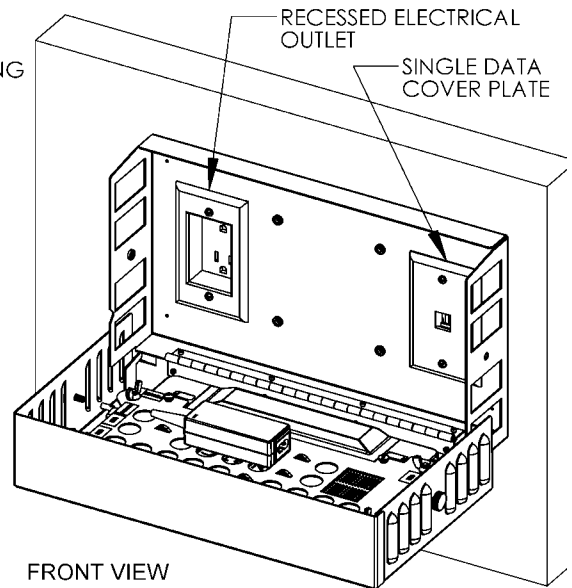
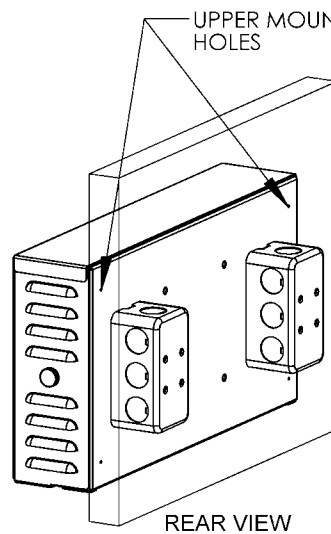

REAR CABLE PATH PLATE DETAIL

- ① REMOVE THE CABLE PATH COVER PLATE AND PULL THE POWER AND DATA CABLES OUT OF THE OPENING.
- ② REPLACE THE COVER PLATE AND ALIGN THE CABLES TO BE IN THE CABLE GROOVES ON THE PLATE.
- ③ REATTACH THE COVER PLATE BY USING THE OTHER SET OF MOUNTING HOLES.



WARNING: If using any PQS mounting product, please refer to that product's installation instructions to correctly install the mount. PQS recommends installation by a professional.

BELOW ARE JUST A FEW OF THE MANY POSSIBLE MOUNTING OPTIONS SOLUTIONS

UNDER COUNTER MOUNT
ATTACHES TO THE UNDERSIDE
OF COUNTER WITH AN 8" ARM
AND A PAN & TILT HEAD.
P/N: 80932

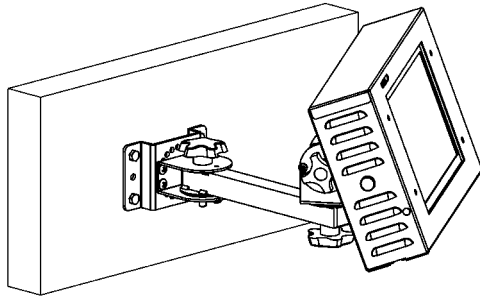
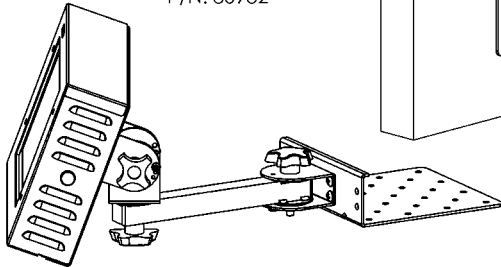

WALL MOUNT WITH 8" ARM
ATTACHES TO ANY WALL SURFACE
WITH AN 8" ARM AND A PAN AND
TILT HEAD FOR MAXIMUM
ADJUSTABILITY AGAINST A WALL.
P/N: 80933

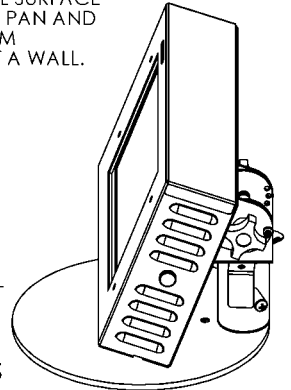

COUNTERTOP PEDESTAL MOUNT
SITS ON ANY HORIZONTAL SURFACE
WITH A PAN AND TILT HEAD ON TOP
FOR CLOSE TO 360° ROTATION.
P/N: 80929

- The Enclosure can be attached directly to a wall or attached to any PQS 100 mm compatible mounting systems. Some examples shown below:

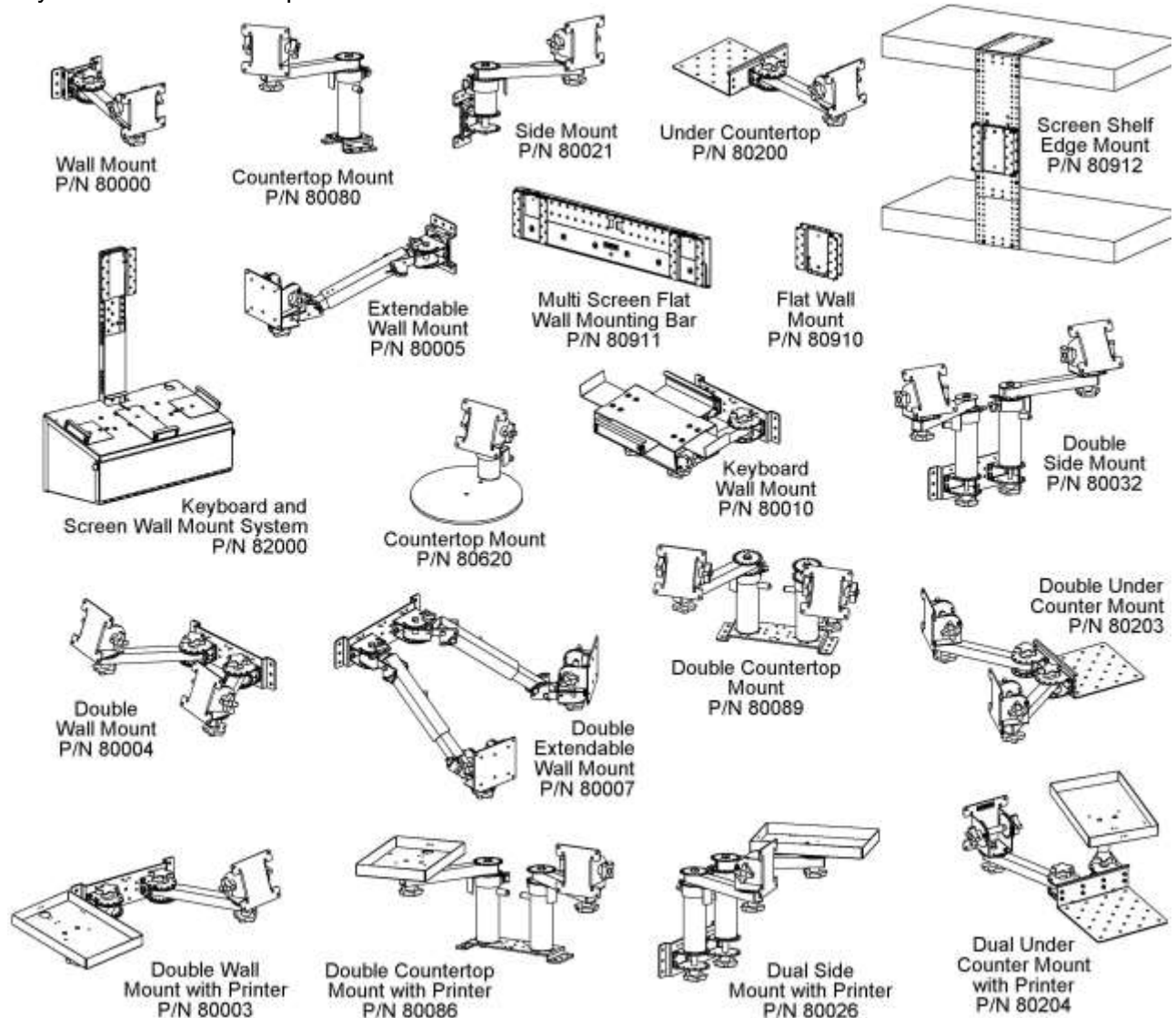

Partner Tech EM-200 Enclosure PN 80927

**MANY DIFFERENT MOUNTING OPTIONS ARE AVAILABLE FOR ALL ENCLOSURES.
SEE OUR MOUNTING SYSTEMS PRODUCT GROUP PAGE FOR DETAILS**

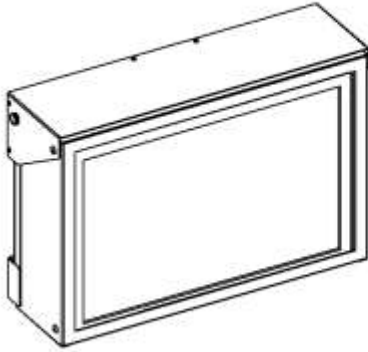

UNIVERSAL ENCLOSURES FOR FLAT
PANEL MONITORS AND THIN CLIENTS
P/N: 80400 - ENCLOSURES FOR 17" - 19"
P/N: 80401 - ENCLOSURES FOR 20" - 24"

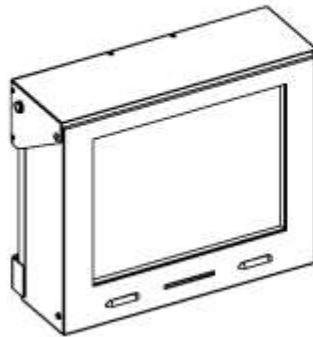

ENCLOSURES FOR AN IBM
APK TOUCH TERMINAL
P/N: 80402

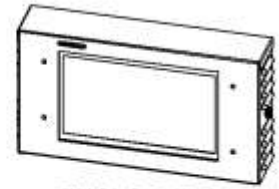

ENCLOSURES
FOR A PARTNER
TECH TABLET PC
P/N: 80927



COUNTER TOP DUAL
ENCLOSURE MOUNT FOR
PARTNER TECH EM-200
P/N: 80921

**SOME EXAMPLES OF ENCLOSURES AND MOUNTING SYSTEMS FOR MONITORS,
TOUCH COMPUTERS, KEYBOARDS, AND THIN CLIENTS**



UNIVERSAL KEYBOARD AND
SCREEN MOUNT SHOWN WITH AN
ALL IN ONE KEYBOARD AND A
FLAT SCREEN MONITOR
P/N : 82010

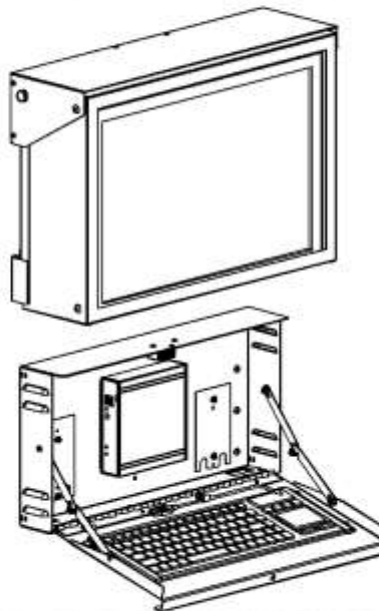

WALL MOUNT ENCLOSURE WITH AN ALL
IN ONE KEYBOARD SHOWN WITH A
UNIVERSAL MONITOR ENCLOSURE AND
A THIN CLIENT
P/N : 80682

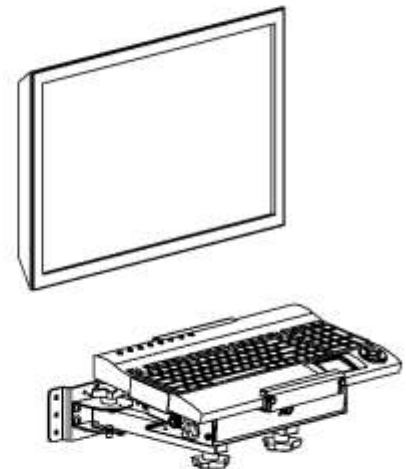

UNIVERSAL WALL MOUNTED
ADJUSTABLE KEYBOARD
TRAY ON TWO ARMS
P/N : 80010