

PQS

Practical Quality Systems®
Fast Custom Manufacturing, Nationwide Installation Services

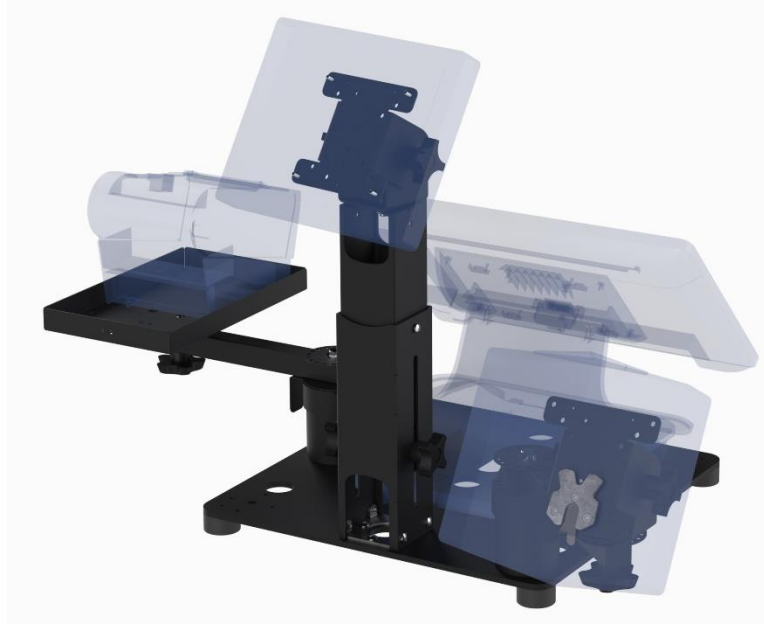

Printer, POS Terminal, VESA Screen, and Payment Terminal shown for illustration only, not included.

Important Note:

This document provides an overview of whole system functionality for all 16X16 Modular Countertop Stand configurations, and may include mention and illustration of features or components not included in each specific product assembly listed at the top of this document. See individual product manuals for accurate depiction of each product assembly.

Table of Contents	
Page	Section Title
2-3	Table of contents
4	An Overview of the 16X16 Modular Countertop Stand System
	PN components and drawing
5	PN 88180 Terminal Countertop Cashier Stand with VESA Customer Display (Tilt Only)
6	PN 88181 Terminal Countertop Cashier Stand with VESA Customer Display (Pan-Tilt)
7	PN 88193 Terminal Countertop Cashier Stand with VESA Customer Display (Tilt-Only) + Printer Tray
8	PN 88194 Terminal Countertop Cashier Stand with VESA Customer Display (Pan-Tilt) + Printer Tray
9	PN 88195 Terminal Countertop Cashier Stand with VESA Customer Display (Tilt-Only) + Ingenico Terminal Mount
10	PN 88196 Terminal Countertop Cashier Stand with VESA Customer Display (Pan-Tilt) + Ingenico Terminal Mount
11	PN 88197 Terminal Countertop Cashier Stand with VESA Customer Display (Tilt-Only) + Printer Tray + Ingenico Terminal Mount
12	PN 88198 Terminal Countertop Cashier Stand with VESA Customer Display (Pan-Tilt) + Printer Tray + Ingenico Terminal Mount
13-18	Additional Pre-Configured Products
19	16X16 Countertop Stand Modular Components
20	Additional Accessories: Enclosures for Related Equipment and Cabling
21	Related Product Categories
22	Understanding the functionality of the 16X16 Base Plate
23	Understanding How the Telescoping Pedestal Assembly Works with the 16X16 Base Plate
24	Understanding How the Riser Assembly Works with the 16X16 Base Plate
25	Riser, Riser Cap and Arm Assembly Overview
26	Flat Printer or Peripherals Tray on an Adjustable Arm Overview
27	Unpacking a 16X16 Modular Countertop Stand with Telescoping Pedestal and Arm Assemblies
28	Understanding the Telescoping Pedestal Assembly
29	Adjusting the Vertical Height Position of the Telescoping Pedestal
30	Understanding Telescoping Pedestal Configurations (Tilt Only vs Pan-Tilt)
31	Adjusting the Tilt Position of a Telescoping Pedestal Assembly (Tilt-Only Configuration)
32	Adjusting the Tilt Position of a Telescoping Pedestal Assembly (Pan-Tilt Configuration)
33	Adjusting the Side-to-Side Position of a Telescoping Pedestal Assembly (Pan-Tilt Configuration)
34	Attaching a Printer and Peripheral Equipment Tray to the End of an Arm Assembly
35	Attaching a Ingenico Lane Pan and Tilt Head to the end of a Riser Arm

36	Installing an Ingenico Lane Reader on the Mounting System
37	Removing an Ingenico Reader from the Mounting System
38	Attaching a VESA Screen to the Telescoping Pedestal Assembly
39-40	Assembling a Telescoping Pedestal (Parts 1 and 2)
41-43	Relocating a Telescoping Pedestal Assembly (Parts 1, 2, and 3)
44	Adjusting the Arm Stop Position of a Riser Assembly
45-46	Relocating a Riser Assembly (Parts 1 and 2)
47	Planning the Installation of the Cabling to the Countertop Stand
48	Routing Cables Through a Telescoping Pedestal Assembly.
49	Routing Cables to a Riser Assembly
50	Understanding the Two Cables on Most Power Bricks
51	On Page SEO and Compatible Devices

An Overview of the 16X16 Modular Countertop Stand System

- The assemblies described in this document are part of the 16X16 system of modular countertop stands.
- This system can be extensively customized to work with Point of Sale (POS), Self Check Out (SCO), Digital Signage and other applications.
- Know that we have pre-configured only a few examples of many possible configurations made possible by our wide array of modular and interchangeable components.
- The heart of this system is a thick, heavy, 16" x 16" square steel "Base Plate" assembly that is supported above a countertop with four, large, non-slip rubber feet. These feet create a ¾" tall concealed pathway for routing cabling below the plate.
- The Base plate also features seven locations for the attachment of multiple Telescopic Pedestal assemblies for VESA screens and "Riser" assemblies that include adjustable arms to support Touch Terminals, Printers, Customer Displays, EMV Card Readers, Barcode Scanners, Scales and other peripheral equipment. Each attachment location features an adjacent cable path hole.
- POS Terminals with integral bases, POS Printers or other equipment can be placed directly on top of the base plate. Depending on the layout of installed equipment, the base plate can also be placed directly on top of a standard (16" x 16") or (18" x 16") cash drawer.
- Know that all individual components are modular and interchangeable which delivers maximum versatility and adaptability, and provides easy reconfiguration to support new peripheral equipment. Systems are available as complete, preconfigured, turnkey kits or can be custom configured to your specifications. Contact our Applications team if you need a quantity of custom assemblies.
- These assemblies are made of steel and finished with a durable, black, micro-wrinkle finish powder coat that resists fingerprints.
- **Note:** For images, descriptions and links to webpages for all pre-configured 16X16 Modular Countertop Stands; review the last pages of this document. For complete specifications on any product; click on the "Product Attachments" tab to download the PDF Product Information Sheet from all individual product pages.
- These systems are compatible with Ingenico Lane (3000, 5000 v2, 7000, 8000), Ingenico Desk (1500) and Ingenico Axiom (RX5000) and future readers equipped with the Ingenico "Clip-In" / "Click-In" mounting standard; we also have solutions for other types of EMV readers.

What makes these systems different?

- No engineering degree required to understand how the individual components fit together.
- The modular design allows total system flexibility for simplified customization.
- There are NO molded plastic structural parts to break or wear out, no springs or pneumatic cylinders to fail and NO special tools required for installation.
- The side-to-side pan position and up-down tilt position of screens, and the vertical height of Pedestals can be adjusted easily without tools to support VESA compatible Point of Sale (POS) or Self Check Out (SCO) terminals.
- The position of arms can be adjusted easily without tools to support EMV readers, POS printers and other peripherals.
- We also have larger countertop systems with many more features, mobile and stationary cabinet systems and stand alone "Pole Systems" for POS and SCO applications as well as stainless steel vertical and horizontal 4X4 wireways.

Need something special?

- Our in-house design team offers fast turnaround on custom parts. If you wish to order a quantity of custom products, we will create a new assembly specifically pre-configured for your application.

PN: 88180

Terminal Countertop Cashier Stand with VESA Customer Display (Tilt Only)

CUSTOMER SCREEN MOUNTS HERE
 - 50/75/100mm VESA COMPATIBLE
 - SUPPORTS PORTRAIT AND LANDSCAPE ORIENTATIONS, UP TO 22" CLASS

TILT-ONLY CONFIGURATION:
 SEE PN 88181 FOR PAN-TILT

POS TERMINAL MOUNTS HERE
 - MOST TERMINALS CAN BE PLACED DIRECTLY ON TOP OF THE BASE.
 - PRINTERS AND OTHER EQUIPMENT CAN ALSO BE PLACED DIRECTLY ON TOP OF THE BASE, OR ADJACENT ON THE COUNTERTOP SURFACE.

TELESCOPING PEDESTAL
 PROVIDES 6" OF VERTICAL ADJUSTMENT

MULTIPLE CABLE PATHS
 HOLES ARE AVAILABLE DIRECTLY BENEATH PEDESTAL ASSEMBLIES, AND ADJACENT TO RISER ASSEMBLIES.

CABLE ROUTES:
 - INSIDE AND THROUGH PEDESTAL ASSEMBLY
 - THROUGH AND BELOW BASE ASSEMBLY

HEAVY DUTY BASE
 1/4" THICK STEEL BASE PLATE WITH (4) 3/4" H RUBBER FEET



[Product Page](#)

PN	QTY	Description
21130	1	16X16 Base Plate Assembly
21131	1	Telescoping Pedestal Mounting Base Kit
21132	1	Telescoping Pedestal Assembly
21137	1	Standard VESA Tilt Plate Assembly for Telescoping Pedestal
21139	1	Cable Management Kit

Note:

- Tilt-Only Configuration
- Supports 50, 75, 100mm VESA screens up to 24" Class.

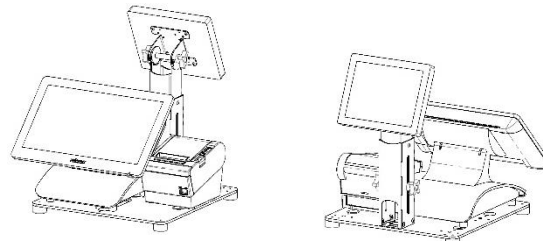

PN: 88181**Terminal Countertop Cashier Stand with VESA Customer Display (Pan-Tilt)****POS TERMINAL MOUNTS HERE**

- MOST TERMINALS CAN BE PLACED DIRECTLY ON TOP OF THE BASE.

- PRINTERS AND OTHER EQUIPMENT CAN ALSO BE PLACED DIRECTLY ON TOP OF THE BASE, OR ADJACENT ON THE COUNTERTOP SURFACE.

HEAVY DUTY BASE

1/4" THICK STEEL BASE PLATE WITH
(4) 3/4" H RUBBER FEET

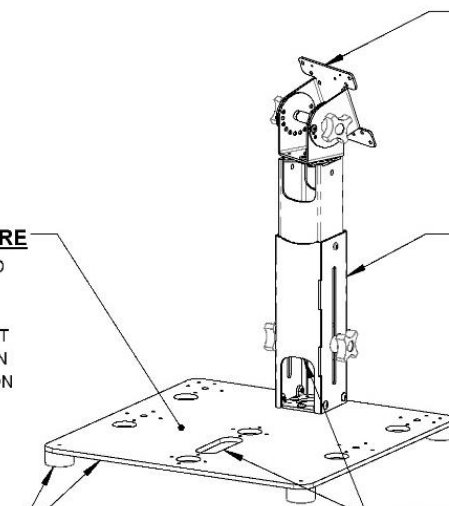
**CUSTOMER SCREEN MOUNTS HERE**

- 50/75/100mm VESA COMPATIBLE
- SUPPORTS PORTRAIT AND LANDSCAPE ORIENTATIONS, UP TO 22" CLASS

PAN-TILT CONFIGURATION:

SEE PN 88180 FOR TILT-ONLY

TELESCOPING PEDESTAL

PROVIDES 6" OF VERTICAL ADJUSTMENT

MULTIPLE CABLE PATHS

HOLES ARE AVAILABLE DIRECTLY BENEATH PEDESTAL ASSEMBLIES, AND ADJACENT TO RISER ASSEMBLIES.

CABLE ROUTES:

- INSIDE AND THROUGH PEDESTAL ASSEMBLY
- THROUGH AND BELOW BASE ASSEMBLY



[Product Page](#)

PN	QTY	Description
21130	1	16X16 Base Plate Assembly
21131	1	Telescoping Pedestal Mounting Base Kit
21132	1	Telescoping Pedestal Assembly
21138	1	Standard VESA Pan-Tilt Head Assembly for Telescoping Pedestal
21139	1	Cable Management Kit

Note:

- Pan-Tilt Configuration
- Supports 50, 75, 100mm VESA screens up to 24" Class.

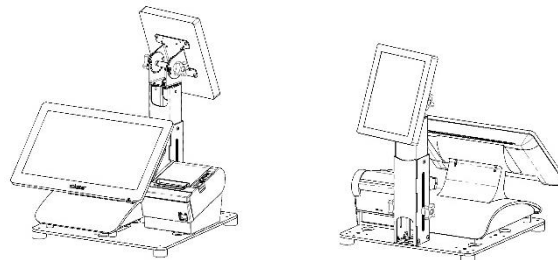

PN: 88193**Terminal Countertop Cashier Stand with VESA Customer Display (Tilt-Only) + Printer Tray****CUSTOMER DISPLAY MOUNTS HERE**

- 50/75/100mm VESA COMPATIBLE
- SUPPORTS MOST POS TERMINALS IN PORTRAIT AND LANDSCAPE ORIENTATIONS, UP TO 22" CLASS

TILT-ONLY CONFIGURATION:
SEE PN 88194 FOR PAN-TILT**POS TERMINAL MOUNTS HERE**

- MOST TERMINALS CAN BE PLACED DIRECTLY ON TOP OF THE BASE.
- PRINTERS AND OTHER EQUIPMENT CAN ALSO BE PLACED DIRECTLY ON TOP OF THE BASE, OR ADJACENT ON THE COUNTERTOP SURFACE.

HEAVY DUTY BASE

1/4" THICK STEEL BASE PLATE WITH
(4) 3/4" H RUBBER FEET

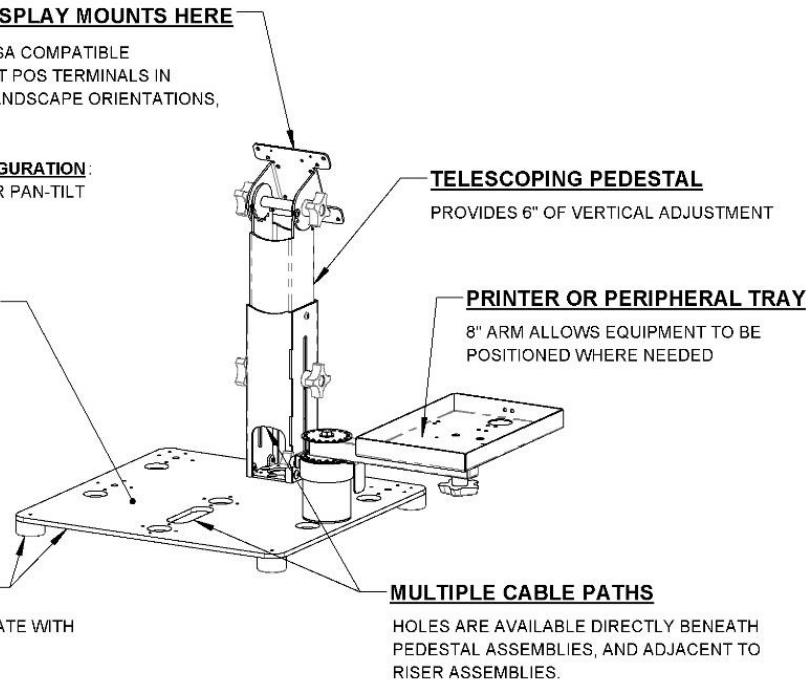
**TELESCOPING PEDESTAL**

PROVIDES 6" OF VERTICAL ADJUSTMENT

PRINTER OR PERIPHERAL TRAY

8" ARM ALLOWS EQUIPMENT TO BE POSITIONED WHERE NEEDED

MULTIPLE CABLE PATHS

HOLES ARE AVAILABLE DIRECTLY BENEATH PEDESTAL ASSEMBLIES, AND ADJACENT TO RISER ASSEMBLIES.

CABLE ROUTES:

- INSIDE AND THROUGH PEDESTAL ASSEMBLY
- THROUGH AND BELOW BASE ASSEMBLY



[Product Page](#)

PN	QTY	Description
21130	1	16X16 Base Plate Assembly
21131	1	Telescoping Pedestal Mounting Base Kit
21132	1	Telescoping Pedestal Assembly
21133	1	3" Riser + Adjustable Arm Assembly
21135	1	Printer and Peripheral Tray Assembly + Arm Mounting Kit
21137	1	Standard VESA Tilt Plate Assembly for Telescoping Pedestal
21139	1	Cable Management Kit

Note:

- Tilt-Only Configuration
- Supports 50, 75, 100mm VESA screens up to 24" Class.

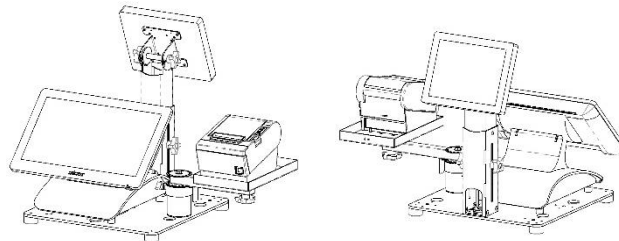

PN: 88194**Terminal Countertop Cashier Stand with VESA Customer Display (Pan-Tilt) + Printer Tray****CUSTOMER DISPLAY MOUNTS HERE**

- 50/75/100mm VESA COMPATIBLE
- SUPPORTS MOST POS TERMINALS IN PORTRAIT AND LANDSCAPE ORIENTATIONS, UP TO 22" CLASS

PAN-TILT CONFIGURATION:
SEE PN 88193 FOR TILT-ONLY

POS TERMINAL MOUNTS HERE

- MOST TERMINALS CAN BE PLACED DIRECTLY ON TOP OF THE BASE.
- PRINTERS AND OTHER EQUIPMENT CAN ALSO BE PLACED DIRECTLY ON TOP OF THE BASE, OR ADJACENT ON THE COUNTERTOP SURFACE.

HEAVY DUTY BASE

1/4" THICK STEEL BASE PLATE WITH
(4) 3/4" H RUBBER FEET

TELESCOPING PEDESTAL

PROVIDES 6" OF VERTICAL ADJUSTMENT

PRINTER OR PERIPHERAL TRAY

8" ARM ALLOWS EQUIPMENT TO BE
POSITIONED WHERE NEEDED

MULTIPLE CABLE PATHS

HOLES ARE AVAILABLE DIRECTLY BENEATH
PEDESTAL ASSEMBLIES, AND ADJACENT TO
RISER ASSEMBLIES.

CABLE ROUTES:

- INSIDE AND THROUGH PEDESTAL ASSEMBLY
- THROUGH AND BELOW BASE ASSEMBLY



[Product Page](#)

PN	QTY	Description
21130	1	16X16 Base Plate Assembly
21131	1	Telescoping Pedestal Mounting Base Kit
21132	1	Telescoping Pedestal Assembly
21133	1	3" Riser + Adjustable Arm Assembly
21135	1	Printer and Peripheral Tray Assembly + Arm Mounting Kit
21138	1	Standard VESA Pan-Tilt Head Assembly for Telescoping Pedestal
21139	1	Cable Management Kit

Note:

- Pan-Tilt Configuration
- Supports 50, 75, 100mm VESA screens up to 24" Class.

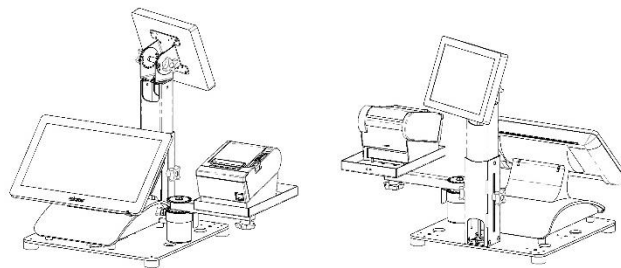

PN: 88195

Terminal Countertop Cashier Stand with VESA Customer Display (Tilt-Only) + Ingenico Terminal Mount

PAYMENT TERMINAL MOUNTS HERE

SUPPORTS INGENICO READERS USING THE INGENICO "CLIP" MOUNTING STANDARD (LANE, DESK, AXIUM)

POS TERMINAL MOUNTS HERE

- MOST TERMINALS CAN BE PLACED DIRECTLY ON TOP OF THE BASE.

- PRINTERS AND OTHER EQUIPMENT CAN ALSO BE PLACED DIRECTLY ON TOP OF THE BASE, OR ADJACENT ON THE COUNTERTOP SURFACE.

HEAVY DUTY BASE

1/4" THICK STEEL BASE PLATE WITH (4) 3/4" H RUBBER FEET

CUSTOMER SCREEN MOUNTS HERE

- 50/75/100mm VESA COMPATIBLE
- SUPPORTS MOST POS TERMINALS IN PORTRAIT AND LANDSCAPE ORIENTATIONS, UP TO 22" CLASS

TILT-ONLY CONFIGURATION:
SEE PN 88196 FOR PAN-TILT

TELESCOPING PEDESTAL

PROVIDES 6" OF VERTICAL ADJUSTMENT

MULTIPLE CABLE PATHS

HOLES ARE AVAILABLE DIRECTLY BENEATH PEDESTAL ASSEMBLIES, AND ADJACENT TO RISER ASSEMBLIES.

CABLE ROUTES:

- INSIDE AND THROUGH PEDESTAL ASSEMBLY
- THROUGH AND BELOW BASE ASSEMBLY



[Product Page](#)

PN	QTY	Description
21130	1	16X16 Base Plate Assembly
21131	1	Telescoping Pedestal Mounting Base Kit
21132	1	Telescoping Pedestal Assembly
21133	1	3" Riser + Adjustable Arm Assembly
21136	1	Ingenico Pan-Tilt Head Assembly + Arm Mounting Kit
21137	1	Standard VESA Tilt Plate Assembly for Telescoping Pedestal
21139	1	Cable Management Kit

Note:

- Tilt-Only Configuration
- Supports 50, 75, 100mm VESA screens up to 24" Class.

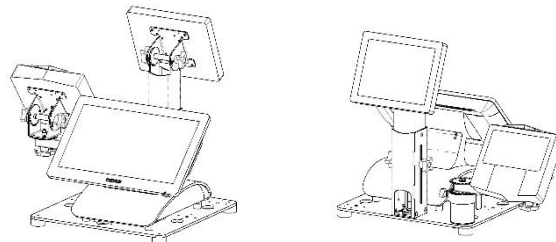

PN: 88196

Terminal Countertop Cashier Stand with VESA Customer Display (Pan-Tilt) + Ingenico Terminal Mount

PAYMENT TERMINAL MOUNTS HERE

SUPPORTS INGENICO READERS USING THE INGENICO "CLIP" MOUNTING STANDARD (LANE, DESK, AXIUM)

POS TERMINAL MOUNTS HERE

- MOST TERMINALS CAN BE PLACED DIRECTLY ON TOP OF THE BASE.

- PRINTERS AND OTHER EQUIPMENT CAN ALSO BE PLACED DIRECTLY ON TOP OF THE BASE, OR ADJACENT ON THE COUNTERTOP SURFACE.

HEAVY DUTY BASE

1/4" THICK STEEL BASE PLATE WITH (4) 3/4" H RUBBER FEET

CUSTOMER SCREEN MOUNTS HERE

- 50/75/100mm VESA COMPATIBLE
- SUPPORTS MOST POS TERMINALS IN PORTRAIT AND LANDSCAPE ORIENTATIONS, UP TO 22" CLASS

TILT-ONLY CONFIGURATION:
SEE PN 88195 FOR TILT-ONLY

TELESCOPING PEDESTAL

PROVIDES 6" OF VERTICAL ADJUSTMENT

MULTIPLE CABLE PATHS

HOLES ARE AVAILABLE DIRECTLY BENEATH PEDESTAL ASSEMBLIES, AND ADJACENT TO RISER ASSEMBLIES.

CABLE ROUTES:

- INSIDE AND THROUGH PEDESTAL ASSEMBLY
- THROUGH AND BELOW BASE ASSEMBLY



[Product Page](#)

PN	QTY	Description
21130	1	16X16 Base Plate Assembly
21131	1	Telescoping Pedestal Mounting Base Kit
21132	1	Telescoping Pedestal Assembly
21133	1	3" Riser + Adjustable Arm Assembly
21136	1	Ingenico Pan-Tilt Head Assembly + Arm Mounting Kit
21138	1	Standard VESA Pan-Tilt Head Assembly for Telescoping Pedestal
21139	1	Cable Management Kit

Note:

- Pan-Tilt Configuration
- Supports 50, 75, 100mm VESA screens up to 24" Class.

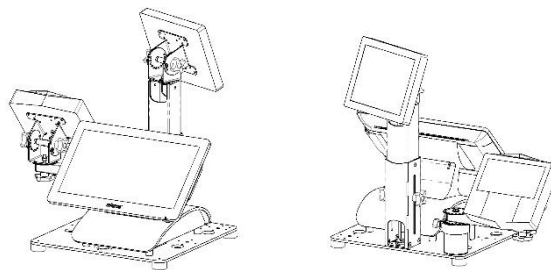

PN: 88197**Terminal Countertop Cashier Stand with VESA Customer Display (Tilt-Only) + Printer Tray + Ingenico Terminal Mount****PAYMENT TERMINAL MOUNTS HERE**

SUPPORTS INGENICO READERS USING THE INGENICO "CLIP" MOUNTING STANDARD (LANE, DESK, AXIUM)

POS TERMINAL MOUNTS HERE

- MOST TERMINALS CAN BE PLACED DIRECTLY ON TOP OF THE BASE.

- PRINTERS AND OTHER EQUIPMENT CAN ALSO BE PLACED DIRECTLY ON TOP OF THE BASE, OR ADJACENT ON THE COUNTERTOP SURFACE.

HEAVY DUTY BASE

1/4" THICK STEEL BASE PLATE WITH (4) 3/4" H RUBBER FEET

CUSTOMER SCREEN MOUNTS HERE

- 50/75/100mm VESA COMPATIBLE
- SUPPORTS MOST POS TERMINALS IN PORTRAIT AND LANDSCAPE ORIENTATIONS, UP TO 22" CLASS

TILT-ONLY CONFIGURATION:

SEE PN 88198 FOR PAN-TILT

TELESCOPING PEDESTAL

PROVIDES 6" OF VERTICAL ADJUSTMENT

PRINTER OR PERIPHERAL TRAY

8" ARM ALLOWS EQUIPMENT TO BE POSITIONED WHERE NEEDED

MULTIPLE CABLE PATHS

HOLES ARE AVAILABLE DIRECTLY BENEATH PEDESTAL ASSEMBLIES, AND ADJACENT TO RISER ASSEMBLIES.

CABLE ROUTES:

- INSIDE AND THROUGH PEDESTAL ASSEMBLY
- THROUGH AND BELOW BASE ASSEMBLY



[Product Page](#)

PN	QTY	Description
21130	1	16X16 Base Plate Assembly
21131	1	Telescoping Pedestal Mounting Base Kit
21132	1	Telescoping Pedestal Assembly
21133	2	3" Riser + Adjustable Arm Assembly
21135	1	Printer and Peripheral Tray Assembly + Arm Mounting Kit
21136	1	Ingenico Pan-Tilt Head Assembly + Arm Mounting Kit
21137	1	Standard VESA Tilt Plate Assembly for Telescoping Pedestal
21139	1	Cable Management Kit

Note:

- Tilt-Only Configuration
- Supports 50, 75, 100mm VESA screens up to 24" Class.

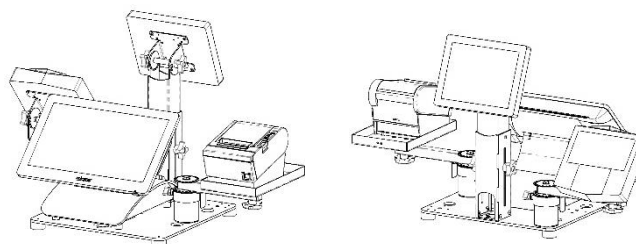

PN: 88198

Terminal Countertop Cashier Stand with VESA Customer Display (Pan-Tilt) + Printer Tray + Ingenico Terminal Mount

PAYMENT TERMINAL MOUNTS HERE

SUPPORTS INGENICO READERS USING THE INGENICO "CLIP" MOUNTING STANDARD (LANE, DESK, AXIUM)

POS TERMINAL MOUNTS HERE

- MOST TERMINALS CAN BE PLACED DIRECTLY ON TOP OF THE BASE.

- PRINTERS AND OTHER EQUIPMENT CAN ALSO BE PLACED DIRECTLY ON TOP OF THE BASE, OR ADJACENT ON THE COUNTERTOP SURFACE.

HEAVY DUTY BASE

1/4" THICK STEEL BASE PLATE WITH (4) 3/4" H RUBBER FEET

CUSTOMER SCREEN MOUNTS HERE

- 50/75/100mm VESA COMPATIBLE
- SUPPORTS MOST POS TERMINALS IN PORTRAIT AND LANDSCAPE ORIENTATIONS, UP TO 22" CLASS

TILT-ONLY CONFIGURATION:
SEE PN 88197 FOR TILT-ONLY

TELESCOPING PEDESTAL
PROVIDES 6" OF VERTICAL ADJUSTMENT

PRINTER OR PERIPHERAL TRAY

6" ARM ALLOWS EQUIPMENT TO BE POSITIONED WHERE NEEDED

MULTIPLE CABLE PATHS

HOLES ARE AVAILABLE DIRECTLY BENEATH PEDESTAL ASSEMBLIES, AND ADJACENT TO RISER ASSEMBLIES.

CABLE ROUTES:

- INSIDE AND THROUGH PEDESTAL ASSEMBLY
- THROUGH AND BELOW BASE ASSEMBLY



[Product Page](#)

PN	QTY	Description
21130	1	16X16 Base Plate Assembly
21131	1	Telescoping Pedestal Mounting Base Kit
21132	1	Telescoping Pedestal Assembly
21133	2	3" Riser + Adjustable Arm Assembly
21135	1	Printer and Peripheral Tray Assembly + Arm Mounting Kit
21136	1	Ingenico Pan-Tilt Head Assembly + Arm Mounting Kit
21138	1	Standard VESA Pan-Tilt Head Assembly for Telescoping Pedestal
21139	1	Cable Management Kit

Note:

- Pan-Tilt Configuration
- Supports 50, 75, 100mm VESA screens up to 24" Class.

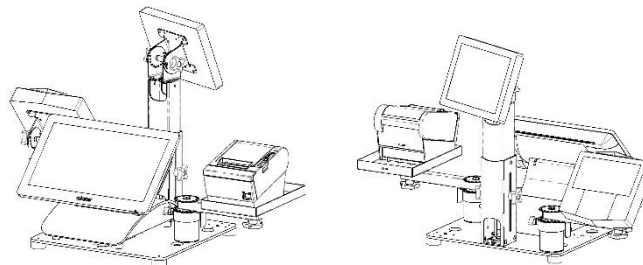

Additional Pre-Configured 16X16 Products:

Countertop Cashier Stand with Tandem Display

Thumbnail	PN	Key Features
	<ul style="list-style-type: none"> ▪ PN 88177 (Tilt-Only VESA) ▪ PN 88178 (Pan-Tilt VESA) 	<ul style="list-style-type: none"> ▪ Supports 1X POS Terminal ▪ Supports 1X VESA Display
	<ul style="list-style-type: none"> ▪ PN 88187 (Tilt-Only VESA) ▪ PN 88188 (Pan-Tilt VESA) 	<ul style="list-style-type: none"> ▪ Supports 1X POS Terminal ▪ Supports 1X VESA Display ▪ Includes 1X Printer Tray
	<ul style="list-style-type: none"> ▪ PN 88189 (Tilt-Only VESA) ▪ PN 88190 (Pan-Tilt VESA) 	<ul style="list-style-type: none"> ▪ Supports 1X POS Terminal ▪ Supports 1X VESA Display ▪ Includes 1X Ingenico Terminal Mount
	<ul style="list-style-type: none"> ▪ PN 88191 (Tilt-Only VESA) ▪ PN 88192 (Pan-Tilt VESA) 	<ul style="list-style-type: none"> ▪ Supports 1X POS Terminal ▪ Supports 1X VESA Display ▪ Includes 1X Printer Tray ▪ Includes 1X Ingenico Terminal Mount

Note:

- Supports most Point of Sale (POS) Terminals.
- Supports most Point of Sale (POS) Printers.
- Supports any 50, 75, 100mm VESA Display, up to 22" Class.

- **Need something special?**

Our in-house design team offers fast turnaround on custom parts. If you wish to order a quantity of custom products, we will create a new assembly specifically pre-configured for your application.

Additional Configurations:

Countertop Cashier Stand with Customer Display

Thumbnail	PN	Key Features
	<ul style="list-style-type: none"> ▪ PN 88230 (Tilt-Only VESA) ▪ PN 88231 (Pan-Tilt VESA) 	<ul style="list-style-type: none"> ▪ Supports 1X POS Terminal ▪ Supports 1X VESA Display
	<ul style="list-style-type: none"> ▪ PN 88232 (Tilt-Only VESA) ▪ PN 88233 (Pan-Tilt VESA) 	<ul style="list-style-type: none"> ▪ Supports 1X POS Terminal ▪ Supports 1X VESA Display ▪ Includes 1X Printer Tray
	<ul style="list-style-type: none"> ▪ PN 88234 (Tilt-Only VESA) ▪ PN 88235 (Pan-Tilt VESA) 	<ul style="list-style-type: none"> ▪ Supports 1X POS Terminal ▪ Supports 1X VESA Display ▪ Includes 1X Ingenico Terminal Mount
	<ul style="list-style-type: none"> ▪ PN 88236 (Tilt-Only VESA) ▪ PN 88237 (Pan-Tilt VESA) 	<ul style="list-style-type: none"> ▪ Supports 1X POS Terminal ▪ Supports 1X VESA Display ▪ Includes 1X Printer Tray ▪ Includes 1X Ingenico Terminal Mount

Note:

- Supports most Point of Sale (POS) Terminals.
- Supports most Point of Sale (POS) Printers.
- Supports any 50, 75, 100mm VESA Display, up to 24" Class.
- **Need something special?**
Our in-house design team offers fast turnaround on custom parts. If you wish to order a quantity of custom products, we will create a new assembly specifically pre-configured for your application.

Additional Configurations:

Countertop Cashier Stand with Customer Display

Thumbnail	PN	Key Features
	<ul style="list-style-type: none"> ▪ PN 88180 (Tilt-Only VESA) ▪ PN 88181 (Pan-Tilt VESA) 	<ul style="list-style-type: none"> ▪ Supports 1X POS Terminal ▪ Supports 1X VESA Display
	<ul style="list-style-type: none"> ▪ PN 88193 (Tilt-Only VESA) ▪ PN 88194 (Pan-Tilt VESA) 	<ul style="list-style-type: none"> ▪ Supports 1X POS Terminal ▪ Supports 1X VESA Display ▪ Includes 1X Printer Tray
	<ul style="list-style-type: none"> ▪ PN 88195 (Tilt-Only VESA) ▪ PN 88196 (Pan-Tilt VESA) 	<ul style="list-style-type: none"> ▪ Supports 1X POS Terminal ▪ Supports 1C VESA Display ▪ Includes 1X Ingenico Terminal Mount
	<ul style="list-style-type: none"> ▪ PN 88197 (Tilt-Only VESA) ▪ PN 88198 (Pan-Tilt VESA) 	<ul style="list-style-type: none"> ▪ Supports 1X POS Terminal ▪ Supports 1X VESA Display ▪ Includes 1X Printer Tray ▪ Includes 1X Ingenico Terminal Mount

Note:

- Supports most Point of Sale (POS) Terminal
- Supports most Point of Sale (POS) Printer
- Supports any 50, 75, 100mm VESA Display, up to 24" Class.
- **Need something special?**
Our in-house design team offers fast turnaround on custom parts. If you wish to order a quantity of custom products, we will create a new assembly specifically pre-configured for your application.

Additional Configurations:

Countertop Cashier Stand with Customer Display

Thumbnail	PN	Key Features
	<ul style="list-style-type: none"> ▪ PN 88230 (Tilt-Only VESA) ▪ PN 88231 (Pan-Tilt VESA) 	<ul style="list-style-type: none"> ▪ Supports 1X POS Terminal ▪ Supports 1X VESA Display
	<ul style="list-style-type: none"> ▪ PN 88232 (Tilt-Only VESA) ▪ PN 88233 (Pan-Tilt VESA) 	<ul style="list-style-type: none"> ▪ Supports 1X POS Terminal ▪ Supports 1X VESA Display ▪ Includes 1X Printer Tray
	<ul style="list-style-type: none"> ▪ PN 88234 (Tilt-Only VESA) ▪ PN 88235 (Pan-Tilt VESA) 	<ul style="list-style-type: none"> ▪ Supports 1X POS Terminal ▪ Supports 1X VESA Display ▪ Includes 1X Ingenico Terminal Mount
	<ul style="list-style-type: none"> ▪ PN 88236 (Tilt-Only VESA) ▪ PN 88237 (Pan-Tilt VESA) 	<ul style="list-style-type: none"> ▪ Supports 1X POS Terminal ▪ Supports 1X VESA Display ▪ Includes 1X Printer Tray ▪ Includes 1X Ingenico Terminal Mount

Note:

- Supports most Point of Sale (POS) Terminals.
- Supports most Point of Sale (POS) Printers.
- Supports any 50, 75, 100mm VESA Display, up to 24" Class.

- **Need something special?**

Our in-house design team offers fast turnaround on custom parts. If you wish to order a quantity of custom products, we will create a new assembly specifically pre-configured for your application.

Additional Configurations:

Countertop Cashier Stand with Customer Display

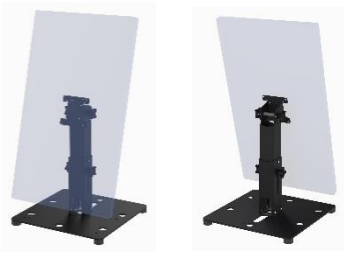
Thumbnail	PN	Key Features
	<ul style="list-style-type: none"> ▪ PN 88183 (Tilt-Only VESA) ▪ PN 88184 (Pan-Tilt VESA) 	<ul style="list-style-type: none"> ▪ Supports 1X POS Terminal or 1X VESA Display

Note:

- Supports most Point of Sale (POS) Terminals.
- Supports most Point of Sale (POS) Printers.
- Supports any 50, 75, 100mm VESA Display, up to 32" Class.
- **Need something special?**
Our in-house design team offers fast turnaround on custom parts. If you wish to order a quantity of custom products, we will create a new assembly specifically pre-configured for your application.

Additional Configurations:

Countertop Cashier Stand with Customer Display

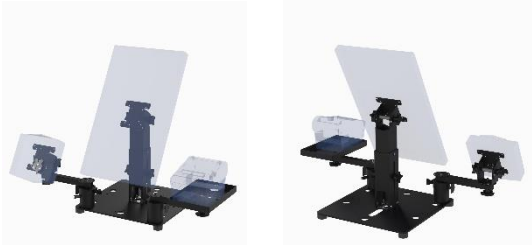
Thumbnail	PN	Key Features
	<ul style="list-style-type: none"> ▪ PN 88210 (Tilt-Only VESA) ▪ PN 88211 (Pan-Tilt VESA) 	<ul style="list-style-type: none"> ▪ Supports 1X POS Terminal ▪ Supports 1X VESA Display











Note:

- Supports most VESA Point of Sale (POS) Terminals.
- Supports most Point of Sale (POS) Printers.
- Supports any 50, 75, 100mm VESA Display, up to 32" Class.

- **Need something special?**



Our in-house design team offers fast turnaround on custom parts. If you wish to order a quantity of custom products, we will create a new assembly specifically pre-configured for your application.

16X16 Modular Countertop Stand Components

THUMBNAIL	PN	DESCRIPTION
	21130	16X16 Base Plate Assembly
	21131	Telescoping Pedestal Mounting Base Kit
	22132	Telescoping Pedestal Assembly
	22133	3" Riser + Adjustable Arm Assembly
	22134	6" Riser + Adjustable Arm Assembly
	22135	Printer and Peripheral Tray Assembly + End of Arm Mounting Kit
	22136	Ingenico Pan-Tilt Head Assembly + End of Arm Mounting Kit
	22137	Standard VESA Tilt-Only Assembly for Telescoping Pedestal
	22138	Standard VESA Pan-Tilt Head Assembly for Telescoping Pedestal
	22022	Standard VESA Conversion Kit (Tilt-Only to Pan-Tilt) for Telescoping Pedestal
	22139	Cable Management Kit
	22021	End of Arm Mounting Kit

Additional Accessories:

Enclosures for Related Equipment and Cabling

THUMBNAIL	PN	Description
	<p>80600-BLK (Black)</p> <p>80600-SLV (Silver)</p>	<p><u>Back of Screen Storage Enclosure,</u></p> <ul style="list-style-type: none"> - 100mm VESA - Powder Coated (Black or Silver)
	<p>80640 (w Lock)</p> <p>80641 (w Latch)</p>	<p><u>Universal Thin Client Security Enclosure,</u></p> <ul style="list-style-type: none"> - Optional Cam Lock or Snap Latch - Powder Coated (Black) - Mounts between the back of any 50, 75,100 or 200mm VESA compatible screen and mounting system, or directly to any horizontal or vertical surface in any orientation. - - <u>Interior dimensions:</u> 2.98 "H x 9.0"W x 13.0"D - <u>Exterior dimensions:</u> 3.2"H x 9.3"W x 13.1"D

Related Product Categories



[Podiums](#)

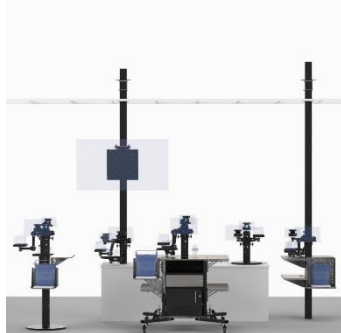

[Cashier Stands](#)

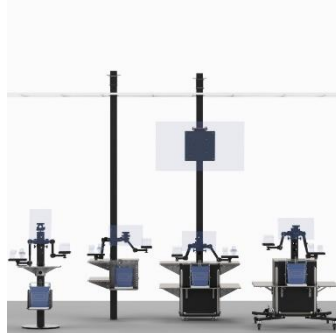

[Self Check Out Stands \(SCO\)](#)

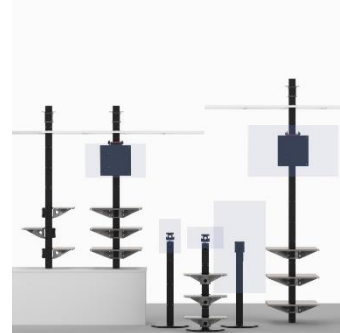

[Take Out Pick Up Stands \(TOPU\)](#)

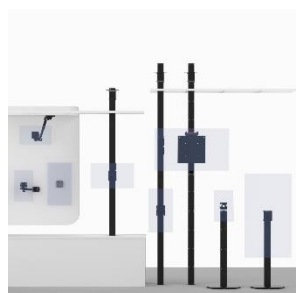

[Digital Signage](#)

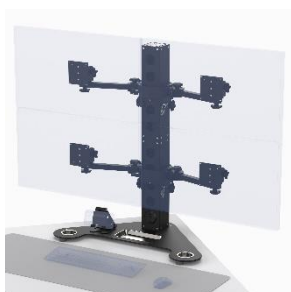

[Desktop Multi-Screen Stands](#)

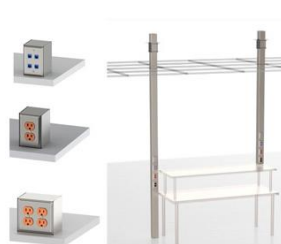

[Stainless Steel Wireways and Accessories](#)



[4X4 Clamp on Mounts and Accessories](#)

Understanding the Functionality of the 16X16 Base Plate

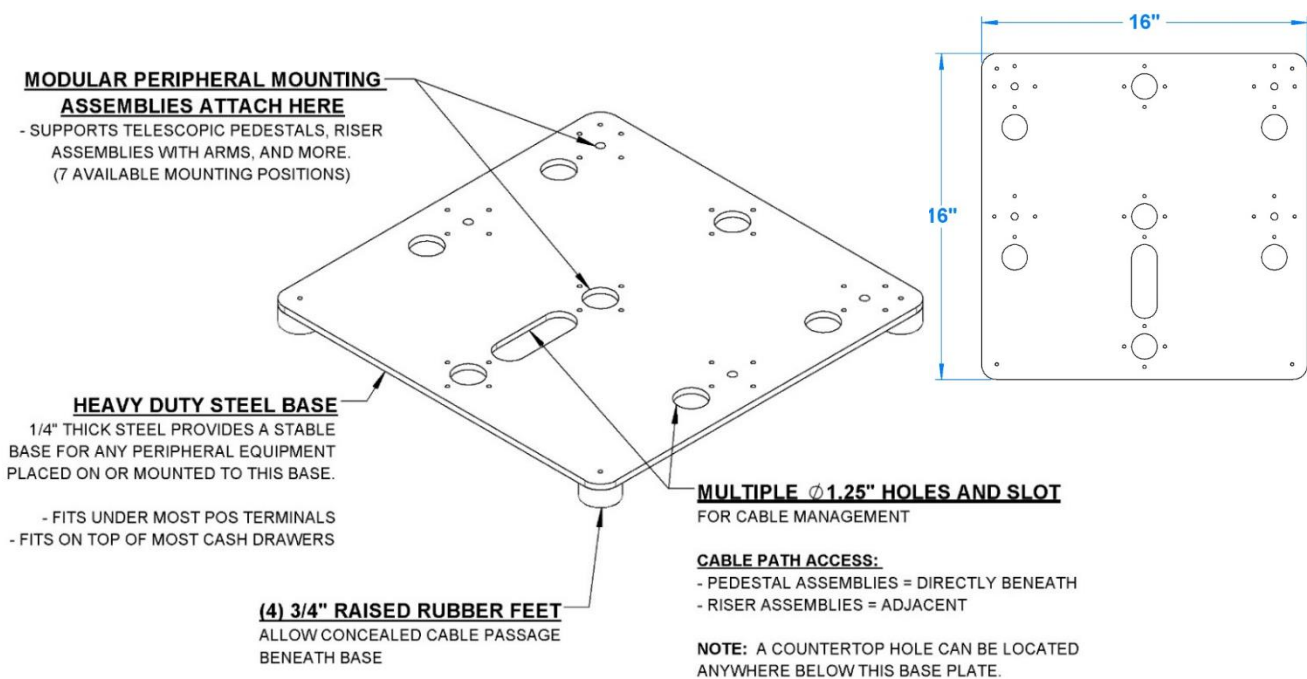

- The base plate assembly measures 16" wide by 16" deep and is made of one piece of heavy, 1/4" thick steel plate to create a stable base for any equipment attached to it.
- The base plate includes four wide rubber feet attached to the bottom of the plate which raise the top of the plate 1" above the countertop. The feet create a 3/4" high space below the entire base plate which allows cabling to be routed out of sight, through any of the eight cable path holes in the plate. A cable passage hole in the countertop can be located anywhere below the plate.
- There are seven attachment locations where Telescopic Pedestal Assemblies can be attached to the top of the Base Plate; the three central positions include a concealed cable path hole directly below the Pedestal.
- There are four attachment locations where Riser Assemblies with Adjustable Arms can be attached to the top of the Base Plate; each position has an adjacent cable path hole.
- POS terminals with integral bases, POS printers, or other equipment can be installed directly on top of the Base Plate Assembly where a large cable path slot provides accommodation for additional cabling needed to support multiple peripherals.
- Depending on the layout of installed equipment; the base plate can be placed directly on top of a standard (16" x 16") or (18" X 16") cash drawer.
- Depending on the product configuration; varying amounts of assembly will be needed to complete the stand after unboxing. Know that although the stand may be partially pre-assembled at the factory; it can be easily reconfigured in the field to be adapted to your application.

When used in Self Check Out (SCO) applications:

The Base Plate is normally oriented to place the side of the plate with three attachment locations along the edge facing towards the customer. This provides ideal locations for mounting Riser and Pedestal assemblies.

When used in Cashier or Point of Sale (POS) applications:

The Base Plate is normally oriented to place the side of the plate with three attachment locations along the edge facing towards the customer. This provides ideal locations for mounting Riser and Pedestal assemblies.

Understanding How the Telescoping Pedestal Assembly Works with the 16X16 Base Plate

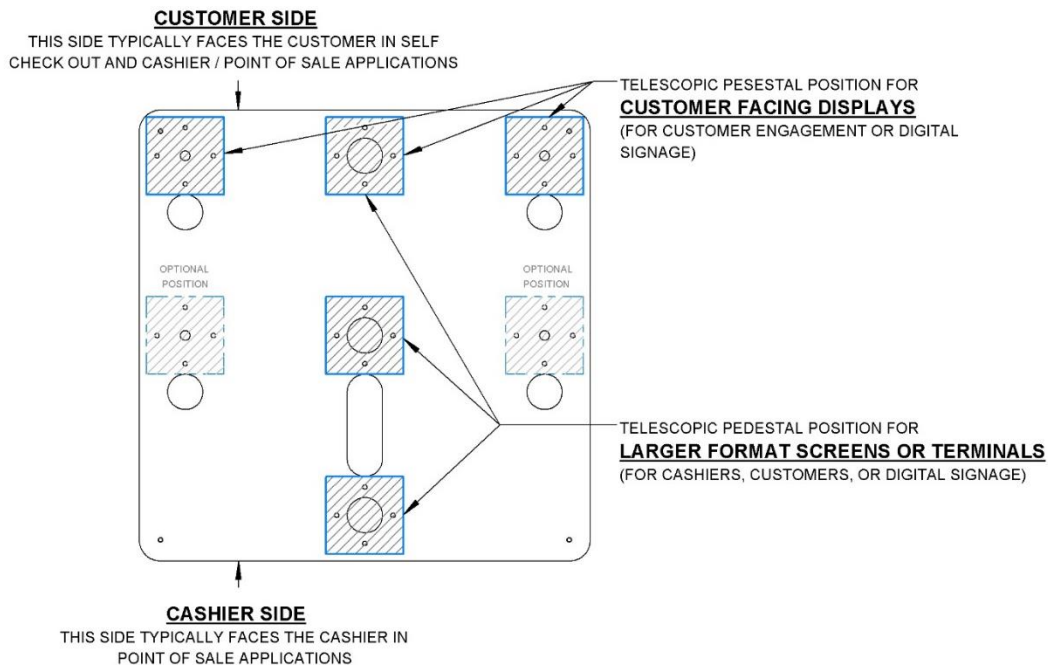

Important note: All Telescoping Pedestals include a lower-outer section with a Mounting Bracket which attaches to the 16X16 Base Plate and an upper-inner Pedestal section that includes an attached, adjustable 50/75/100mm VESA compatible mounting plate assembly. As shipped; the Pedestal assembly Mounting Bracket will be pre-installed and located as specified in the drawings for each product assembly. Know that the pedestal assemblies can be relocated in the field by the user. Refer to the sections: **Relocating a Telescoping Pedestal Assembly (Parts 1+2)**

There are two basic types of telescopic pedestal assemblies:

- **“Tilt Only”** type includes a VESA screen mounting plate which allows up and down screen tilt position adjustment.
- **“Pan-Tilt”** type includes a VESA screen mounting plate which allows up and down screen tilt position adjustment and side-to-side screen pan position adjustment.
- **BOTH types** use the SAME mounting procedure for attaching the Pedestal Assembly to the Base Plate Assembly. A Pedestal Assembly originally configured as one type be easily converted in the field to the other type; Refer to section: **Understanding the Telescopic Pedestal Assembly**

Refer to sections: **Planning the installation of the cabling to the countertop Stand, Tips on routing cabling through a telescopic pedestal assembly.**

- There are seven attachment locations where Telescopic Pedestal assemblies can be attached to the top of the Base Plate; the three locations along the center of the Base Plate include concealed cable path holes directly below the Pedestal. The four other locations have cable passage holes adjacent to the Pedestal.
- The Pedestal allows 6 inches of vertical height adjustment of the VESA mounting plate and is adjusted using the 2 four-point knobs on the sides of the lower-outer section of the Pedestal. Two Pedestal height position locking screws are used to permanently secure the height position. The inside of the Pedestal is hollow which allows screen cabling to be routed internally and out of sight.

Understanding How the Riser Assembly Works with the 16X16 Base Plate

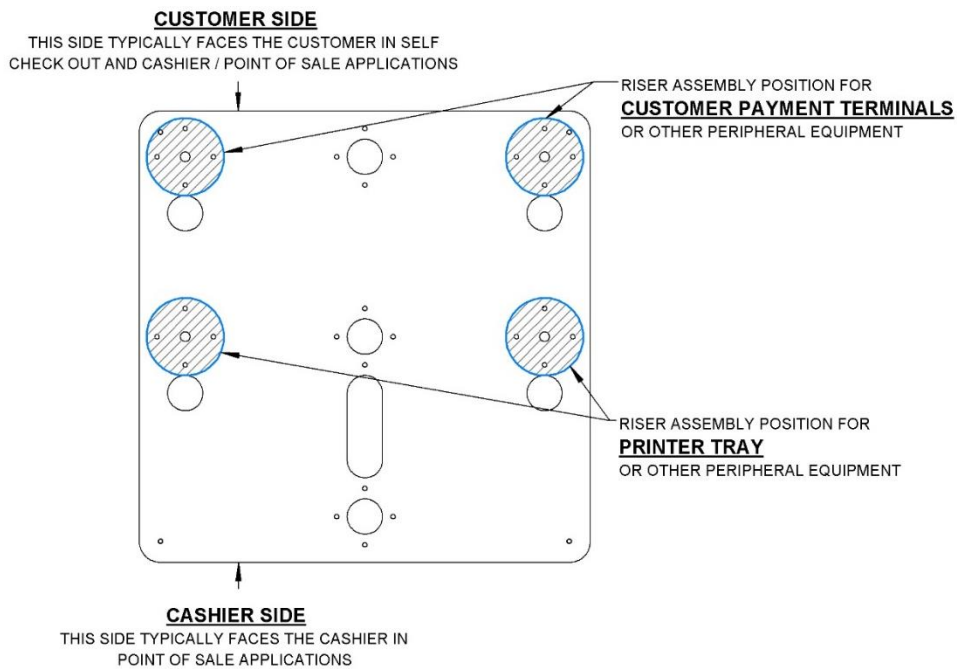

- There are four attachment locations where Riser assemblies with adjustable arms can be attached to the top of the Base Plate; each has an adjacent cable path hole.
- The Riser assembly includes a cylindrical Riser section, a Riser Cap assembly and an 8" Arm Assembly.
- One end of the Arm is permanently attached to the Riser Cap on the top of the Riser and the free end of the Arm can support either a Printer and Peripheral Tray, a VESA Pan-Tilt Head Assembly with up to a 32" class 50/75/100mm VESA compatible screen, or a Pan-Tilt Head Assembly with support for a variety of Ingenico and other EMV readers.
- The Riser Section elevates the Arm above the Base Plate Assembly and permits the screen Pan-Tilt Head, EMV Reader, or a Peripheral Tray (or any other items attached to the end of the arm) to travel horizontally around the top of the Riser assembly to allow a wide range of positioning options.
- When the three-point knob on the side of the Riser cap is tightened; the rotational position of the adjustable Arm will be locked; when the knob is loosened the Arm will be free to rotate around the top of the Riser Assembly.
- As shipped; the Riser Assemblies and Riser Stops will be pre-installed and located as specified in the drawings for each product assembly and the riser stop will have been set to allow the Arm to rotate within a range that is most commonly used.
- Know that the Risers can be relocated and the Riser Stops can be reset in the field by the user; refer to the sections: **Attaching a Riser Assembly to the Base Plate, Understanding the Functionality of the 16X16 Base Plate, Understanding the Functionality of the Riser Assemblies, Relocating a Riser Assembly (Parts 1+2), Adjusting the Arm Stop Position of a Riser Assembly**
- Evaluate the side-to-side range of motion of the Arm that is attached to the Riser Cap and understand how the Arm Stop on the side of the riser prevents the Riser Cap and Arm from rotating a full 360 degrees around the Riser. It may be advantageous to relocate the stop position to optimize the side-to-side range of motion of the Arm for your application.
- Cabling can be attached directly to the Arm and to a cable tie point on the Riser Cap assembly.

Riser, Riser Cap and Arm Assembly Overview

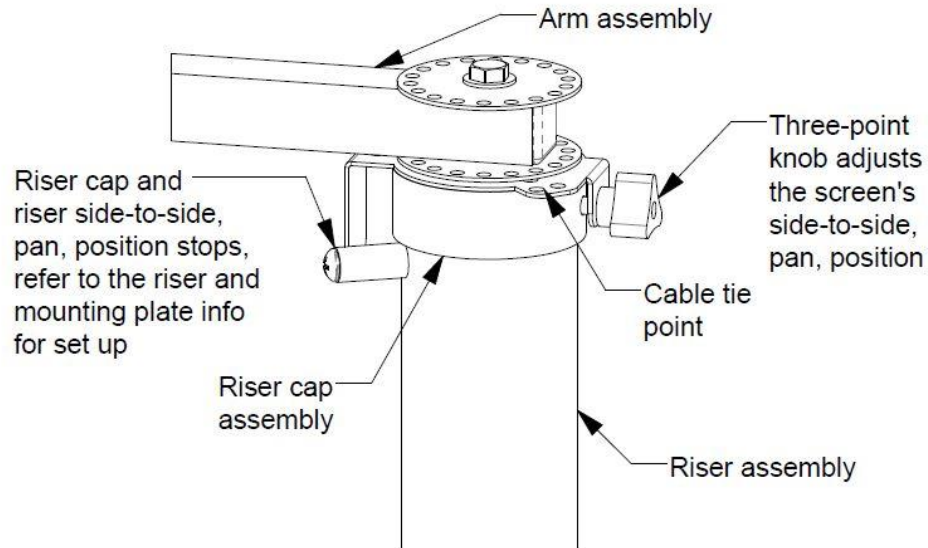

- The Riser Cap allows an arm to rotate around the top of a Riser assembly.
- Loosening the three - point knob on the side of the Riser Cap allows adjustment of the side-to-side pan position of the arm around the top of the riser assembly. Tightening the knob locks the position of the arm.
- The Riser cap incorporates a cable tie point to secure the cables so that they will travel safely as the arm is rotated.
- The Riser Cap interacts with the Riser Cap Stop on the side of the Riser to prevent the arm from making a full rotation around the riser. This location can be adjusted in the field by the user; refer to the Riser the section; Adjusting the arm stop position of a Riser assembly

SOME COMPONENTS DEPICTED MAY NOT BE INCLUDED IN YOUR PRODUCT ASSEMBLY, SHOWN FOR ILLUSTRATION ONLY.

Flat Printer or Peripherals Tray on Adjustable Arm Overview

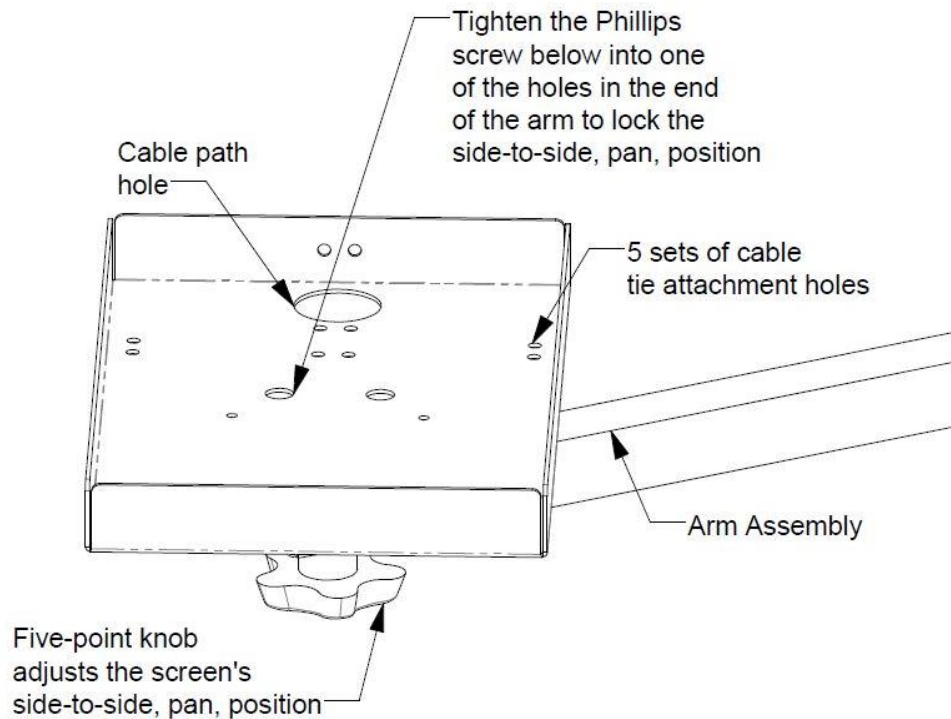

- A universal mount that works with most POS printers and a wide array of POS peripheral equipment such as EMV Card Readers, Barcode scanners, Scales and more .
- The interior dimensions of the Flat Printer Tray are 6½" W X 10¼" L X 1" D.
- Includes a ¼" diameter hole on one end of the tray for routing the power and data cables below the tray if desired.
- Includes multiple sets of tie point holes for inserting cable ties to secure the power and data cables if desired.
- Tightening the five- point knob below the end of the Arm applies variable resistance to allow adjustment of the side-to-side pan position of the Tray. A 10-32 Phillips head screw in one of the center holes can be tightened into one of the holes on the end of the arm to permanently secure the rotation of the tray.
- If a POS printer is installed on the tray; the power supply cable can be installed behind the printer on the tray if the surplus associated cabling is tightly bundled. Cabling can be routed thru the cable passage hole in the rear of the tray and can be attached directly to the arm with cable ties or hook and loop straps.

SOME COMPONENTS DEPICTED MAY NOT BE INCLUDED IN YOUR PRODUCT ASSEMBLY, SHOWN FOR ILLUSTRATION ONLY.

The following is a partial List of compatible printers:

Anser U2, Brother QL 800, Brother PTP700, Citizen CT-E351, Clover P500, Clover Mini, Custom, America CT-E351, Dymo LabelWriter 450, Dymo LabelWriter Wireless, Dymo LabelManager PnP, Epson TM-T88V/VI, Epson TM- T20II, Epson TM - L90, EpsonTM-U220 Type B & D, POS-X Evo HiSpeed, Rollo Printer, Sato FX3-LX, Sato WS2, Square Terminal, Star Micronics mC-Print3.

Unpacking a 16X16 Modular Countertop Stand with Telescoping Pedestal and Arm Assemblies

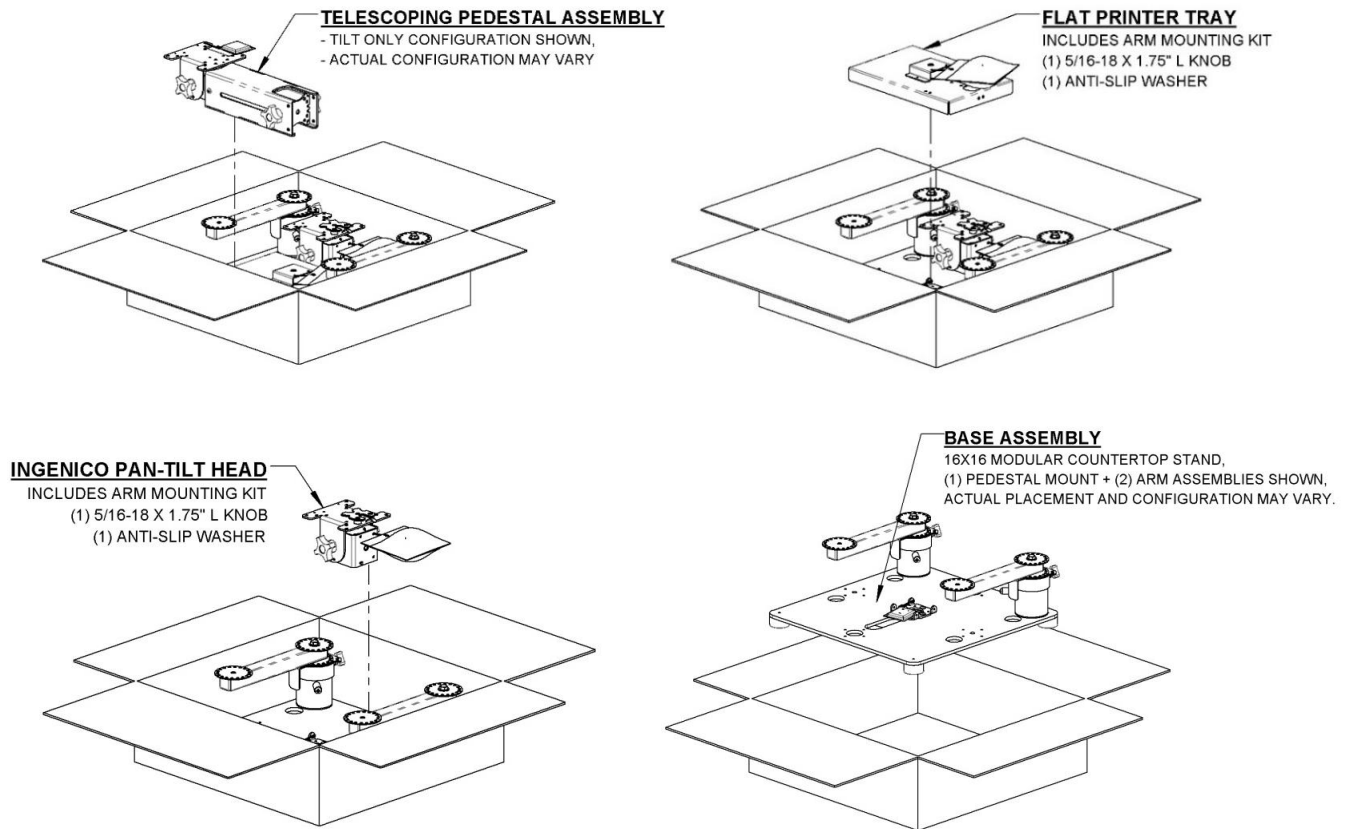

- Important Note: please read the entire assembly instructions contained in the product manual before proceeding.
- As shipped from the factory, the mounting bracket for the pedestal assemblies and the riser assemblies will be pre attached to the Base Plate at the position indicated in each product manual.
- All components will be individually wrapped; the Pedestal Assemblies and the Peripheral Assemblies which attach to the ends of the arms on the Riser Assemblies will need to be unwrapped and installed using the included hardware pre-attached to each Peripheral Assembly.
- Open the top of the box and carefully remove any individually wrapped components.
- Carefully lift the Base Plate assembly from the box complete with the pre-installed Pedestal Mounting Bracket and Riser Assemblies.
- Remove the packaging from the Base Plate Assembly and each of the individual component assemblies. Take care to retain all of the associated hardware included with the individual assemblies.
- Before proceeding; refer to the various sections that detail how to assemble your system.

SOME COMPONENTS DEPICTED MAY NOT BE INCLUDED IN YOUR PRODUCT ASSEMBLY, SHOWN FOR ILLUSTRATION ONLY.

Understanding the Telescoping Pedestal Assembly

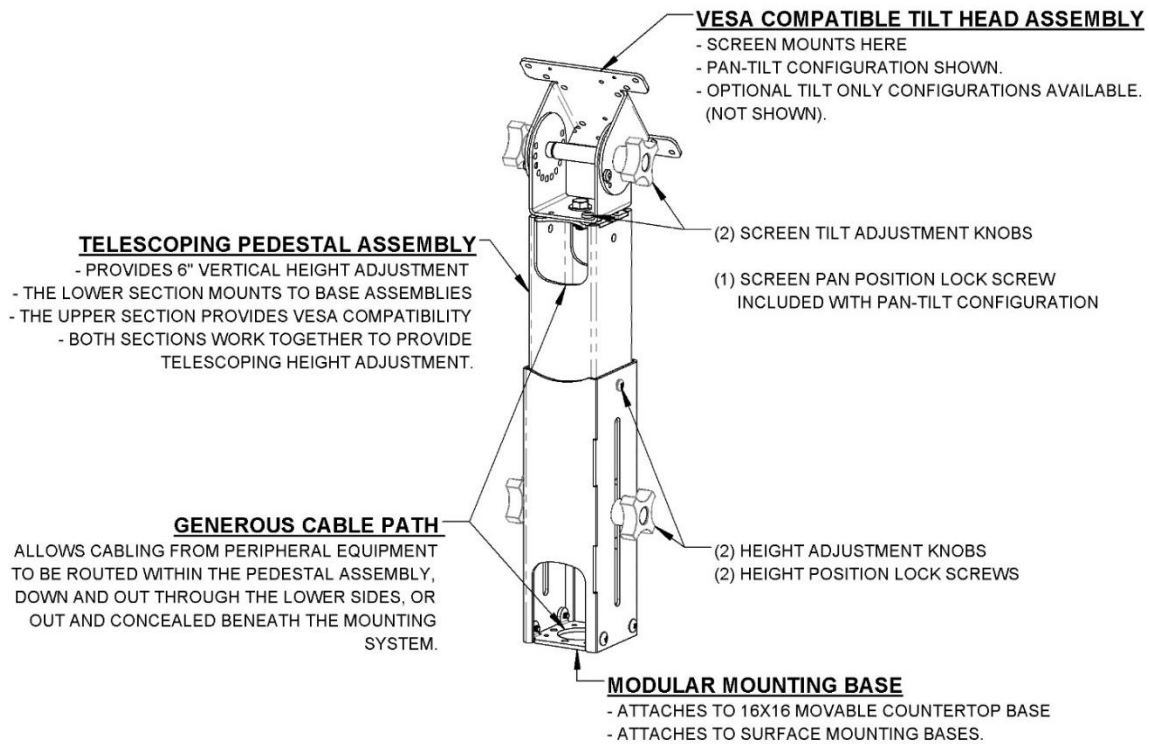

- Two four-point height adjustment knobs travel in slots on the sides of the lower-outer section to allow up to 6 inches of vertical height adjustment.
- When the pedestal is in the fully extended position; the knobs will prevent the upper-inner section from being completely removed from the lower-outer section.
- Conversely; when the pedestal is in the fully retracted position; the bottom of the upper-inner section will automatically stop when it contacts the bottom of the larger lower-outer section.
- Generous cable path clearance openings allow routing of cabling from associated peripheral equipment into and through the Telescoping Pedestal Assembly, down and out through the sides of the Lower Pedestal section, or down through the Mounting Base to route cabling below Movable Countertop Base Systems.
- The telescoping pedestal assembly is compatible with 16X16 Movable Countertop Systems, and both Single-Position and Three-Position mounting bases to create Direct Mount Countertop Telescoping Pedestal assemblies.

SOME COMPONENTS DEPICTED MAY NOT BE INCLUDED IN YOUR PRODUCT ASSEMBLY, SHOWN FOR ILLUSTRATION ONLY.

Adjusting the Vertical Height Position of the Telescoping Pedestal

1. Before proceeding, verify that the height adjustment knob is tight and then loosen one or both of the pedestal lock screws as needed.
2. Support the VESA screen tilt plate or the screen if one is already installed; then slowly loosen the two four knobs just enough so that the upper-inner section can be moved.
3. Carefully lift the VESA screen tilt plate or the screen to the desired new position; then retighten the knobs to secure the new position.

Permanently locking the height position of the Telescopic Pedestal

- If you wish to lock the height position of the screen; locate the pedestal height position locking screws adjacent to the height adjustment slots on the sides of the outer section.
- Use a Phillips screwdriver to tighten one or both of the 10-32 screws.
- To unlock the pedestal height position; loosen the locking screws just enough so that the upper-inner section can be easily moved within the larger lower- outer section.

RANGE OF MOTION:
TILT ONLY CONFIGURATION
*SHOWN WITH 21.5" DISPLAY, NOT INCLUDED

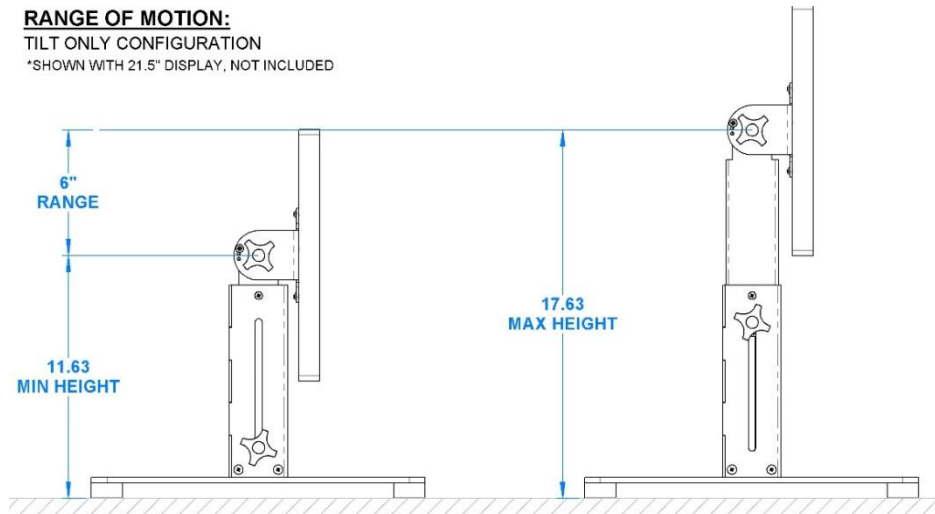

RANGE OF MOTION:
PAN AND TILT CONFIGURATION
*SHOWN WITH 21.5" DISPLAY, NOT INCLUDED

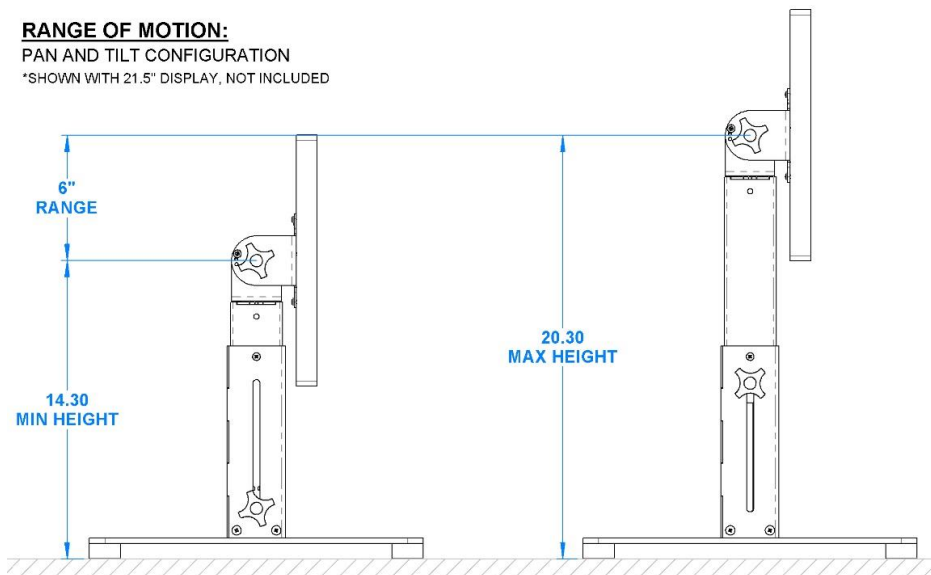

SOME COMPONENTS DEPICTED MAY NOT BE INCLUDED IN YOUR PRODUCT ASSEMBLY, SHOWN FOR ILLUSTRATION ONLY.

Understanding Telescoping Pedestal Configurations (Tilt Only vs Pan-Tilt)

Important Note: A Pedestal Assembly originally configured as one type (Pan-Tilt, or Tilt Only) can be easily converted in the field to the other type. The following instructions are an overview of the conversion process.

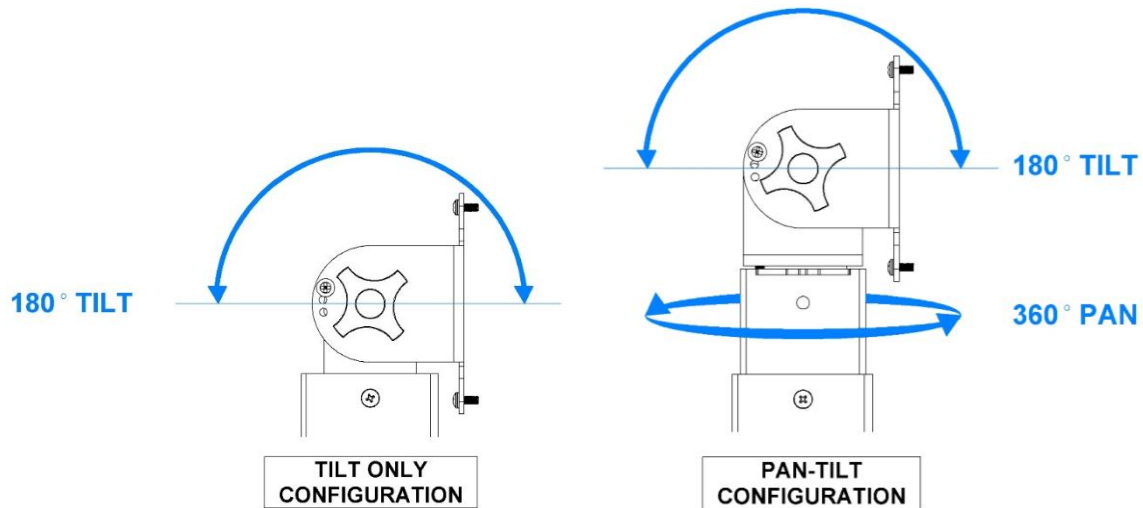

- **Tilt Only to Pan-Tilt:** Contact our support team for a Conversion Kit (PN 22022-KIT). Printed instructions will be provided with conversion kits.

Remove the VESA Tilt Plate from the Pedestal Assembly, invert the upper-inner pedestal section. Use the Conversion Kit hardware to install your existing VESA Tilt Plate and Knobs onto a new VESA Pan Bracket. Then using additional Conversion Kit hardware you will install the VESA Pan-Tilt Head onto the top of your Pedestal Assembly.

- **Pan-Tilt to Tilt Only:** No additional hardware required.

Uninstall the VESA Pan-Tilt Assembly and remove the lower pan bracket from the assembly, keep the Tilt Plate and other hardware, invert the upper-inner Pedestal Section, then re install the Tilt Plate with anti-slip washers, spacer and knobs.

SOME COMPONENTS DEPICTED MAY NOT BE INCLUDED IN YOUR PRODUCT ASSEMBLY, SHOWN FOR ILLUSTRATION ONLY.

Adjusting the Tilt Position of a Telescoping Pedestal Assembly (Tilt-Only Configuration)

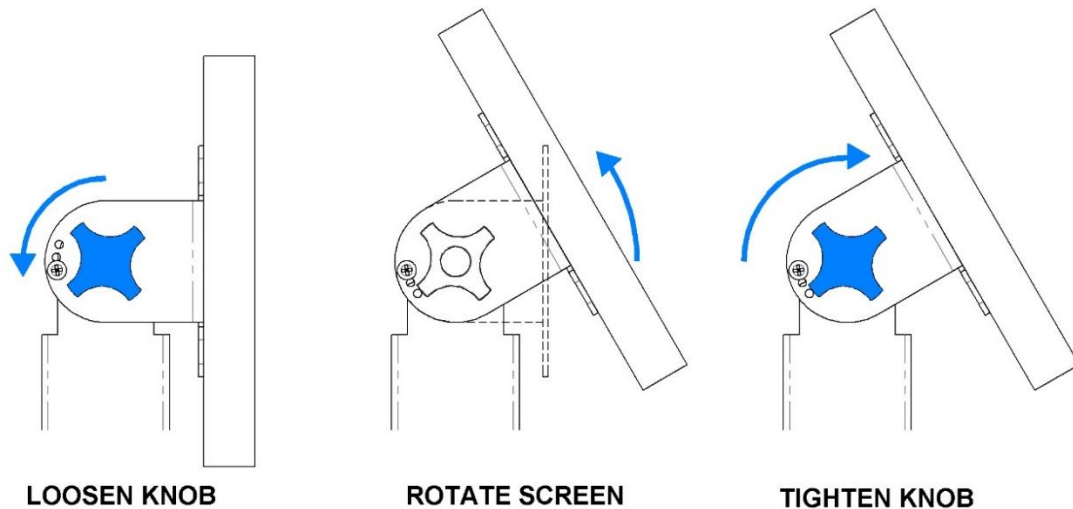

Adjusting the screen up and down tilt position

- Two rubber clutch washers are installed between the sides of the VESA Tilt bracket and the top of the pedestal to provide smooth variable resistance to the tilt function.
- Slightly loosen the two four-point hand knobs on each side of the screen mounting plate, move the screen to the new desired up and down tilt position and then retighten the knobs.

To permanently lock the tilt position of the screen

- Tighten either of the two 10-32 Phillips head screws adjacent to the four-point knobs on the sides of the VESA tilt plate when they are correctly aligned with any of the holes in the vertical inner flanges on the sides of the upper-inner pedestal section.
- To unlock the screen tilt position; loosen the locking screws just enough so that the VESA tilt plate can be easily moved up and down.

Note: a Telescoping Pedestal Assembly that was originally configured with either a Tilt Only or a Pan-Tilt VESA Assembly can be easily converted in the field to be either configuration. See section: **Understanding Tilt Only and Pan-Tilt Configurations**

SOME COMPONENTS DEPICTED MAY NOT BE INCLUDED IN YOUR PRODUCT ASSEMBLY, SHOWN FOR ILLUSTRATION ONLY.

Adjusting the Tilt Position of a Telescoping Pedestal Assembly (Pan-Tilt Configuration)

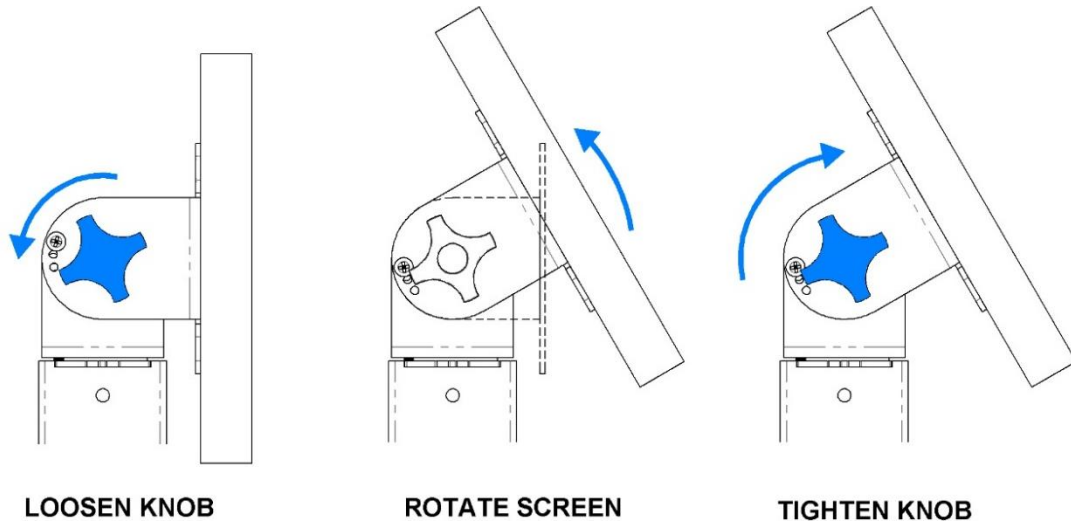

- Two rubber clutch washers are installed between the sides of the VESA Tilt bracket and the top of the pedestal to provide smooth variable resistance to the tilt function.
- Slightly loosen the two four point knobs on each side of the VESA screen mounting plate, move the screen to the new desired position and then retighten the knobs.

To permanently lock the tilt position of the screen:

- Tighten either of the two 10-32 Phillips head screws adjacent to the four-point knobs on the sides of the VESA tilt plate when they are correctly aligned with any of the holes in the vertical inner flanges on the sides of the upper-inner pedestal section. To unlock the screen tilt position; loosen the locking screws just enough so that the VESA tilt plate can be easily moved up and down.

Note: a Telescoping Pedestal Assembly that was originally configured with either a Tilt Only or a Pan-Tilt VESA Assembly can be easily converted in the field to be either configuration. See section: **Understanding Tilt Only and Pan-Tilt Configurations**

SOME COMPONENTS DEPICTED MAY NOT BE INCLUDED IN YOUR PRODUCT ASSEMBLY, SHOWN FOR ILLUSTRATION ONLY.

Adjusting the Side-to-Side Position of a Telescoping Pedestal Assembly (Pan-Tilt Configuration)

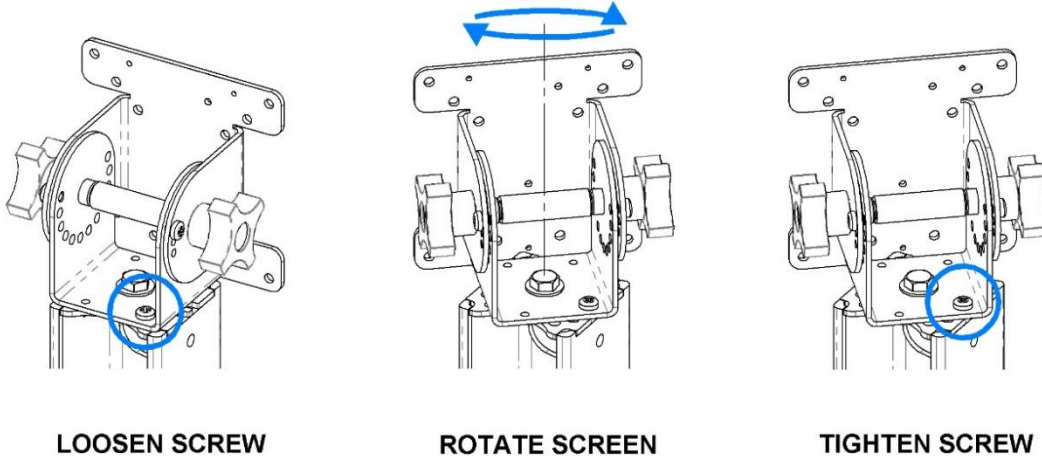

- A rubber clutch washer is installed between the bottom of the pan bracket and the top of the pedestal to provide smooth variable resistance to the side to side pan function.
- The pan position clutch washer is secured by a 5/16"-18 Bolt that is tightened to a preset resistance tension at the factory. However; if desired; the resistance tension of this bolt can be adjusted by the user with a 1/2" wrench to increase or decrease the amount of resistance applied to the clutch washer.

To permanently lock the pan position of the screen:

- Tighten the 10-32 Phillips head screw at the base of the VESA assembly into any of the holes in the horizontal plate at the top of the upper-inner pedestal section. To unlock the screen pan position; loosen the locking screw so that the pan bracket can be moved side to side.
- **Note:** A Telescoping Pedestal Assembly that was originally configured with either a Tilt Only or a Pan-Tilt VESA Assembly can be easily converted in the field to be either configuration. See section: **Understanding Tilt Only and Pan-Tilt Configurations**

SOME COMPONENTS DEPICTED MAY NOT BE INCLUDED IN YOUR PRODUCT ASSEMBLY, SHOWN FOR ILLUSTRATION ONLY.

Attaching a Printer and Peripheral Equipment Tray to the End of an Arm Assembly

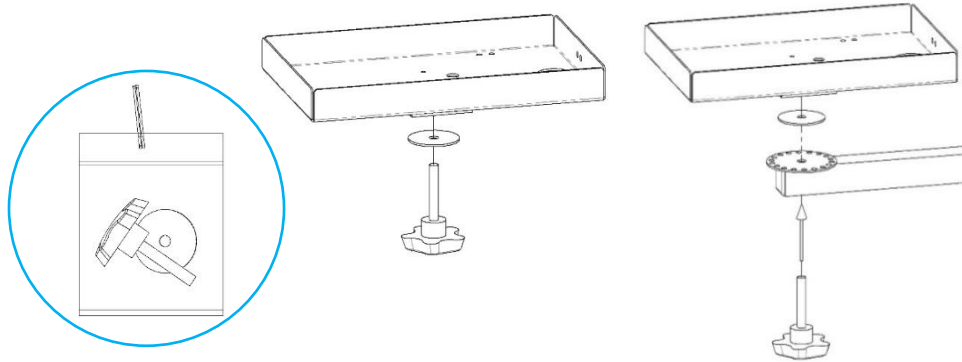

1. As shipped; POS Printer - Peripheral Equipment Trays will need to be installed onto the end of the riser arm.
2. To install the Printer Tray; locate the included End of Arm Hardware Mounting Kit, and identify the five-point knob and rubber clutch washer.
3. Place the rubber clutch washer on the top of the end of the arm and align the hole in the center of the washer with the hole on the end of the arm.
4. Carefully lift the printer tray and align the tapped hole in the base of the tray on top of the rubber clutch washer on the top of the end of the arm, install the shaft of the five-point hand knob up through the underside of the arm, through the rubber clutch washer and then carefully thread it into the base of the printer tray.
5. Use the five-point hand knob to apply variable resistance to adjust the amount of force that will be required to rotate the tray on the end of the arm.
6. To lock the rotation of the tray on the end of the arm; use a #2 Phillips screwdriver to tighten the 10-32 screw in the hole near the center of the tray into one of the holes in the round plate on the end of the arm; to unlock the rotation of the tray simply loosen the screw.
7. The power supply cable be installed behind the printer on the tray and the surplus associated cabling is tightly bundled. Cabling can be routed thru the cable passage hole in the rear of the tray and can be attached directly to the arm with cable ties or hook and loop straps. Always provide enough slack cabling to allow freedom of movement of the tray around the end of the arm and the travel of the arm around the riser.

SOME COMPONENTS DEPICTED MAY NOT BE INCLUDED IN YOUR PRODUCT ASSEMBLY, SHOWN FOR ILLUSTRATION ONLY.

Attaching a Ingenico Lane Pan and Tilt Head to the end of a Riser Arm

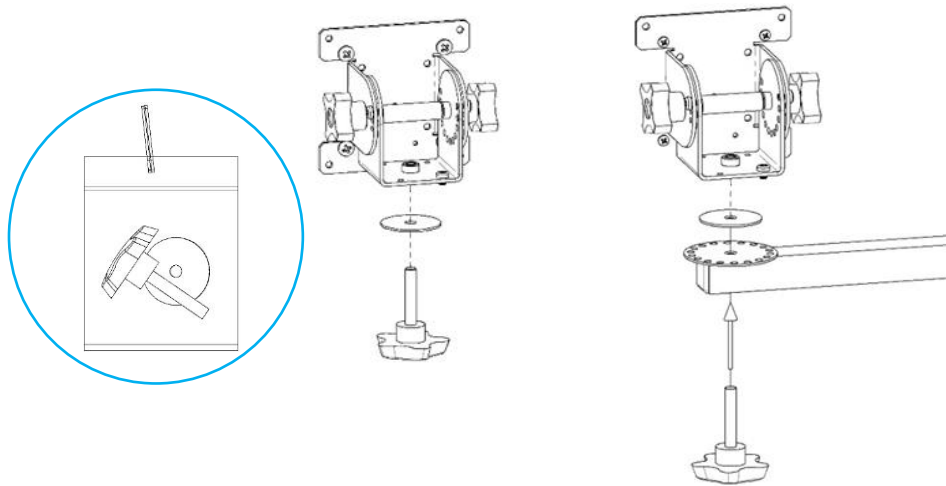

1. As shipped the Ingenico Lane Pan and Tilt Head will need to be installed onto the end of the riser arm.
2. To install the Ingenico Lane Pan and Tilt Head; locate the included End of Arm Hardware Mounting Kit, and identify the five-point knob and rubber clutch washer.
3. Place the rubber clutch washer on the top of the end of the arm and align the hole in the center of the washer with the hole on the end of the arm.
4. Carefully lift the Pan and Tilt Head and align the tapped hole in the base of the head on top of the rubber clutch washer on the top of the end of the arm, install the shaft of the five-point hand knob up through the underside of the arm, through the rubber clutch washer and then carefully thread it into the base of the Pan and Tilt Head.
5. Use the five-point hand knob to apply variable resistance to adjust the amount of force that will be required to rotate the Pan and Tilt Head on the end of the arm.
6. To lock the rotation of the Pan and Tilt Head on the end of the arm; use a #2 Phillips screwdriver to tighten the 10-32 screw in the base of Pan and Tilt Head into one of the holes in the round plate on the end of the arm; to unlock the rotation of the Pan and Tilt Head simply loosen the screw.

SOME COMPONENTS DEPICTED MAY NOT BE INCLUDED IN YOUR PRODUCT ASSEMBLY, SHOWN FOR ILLUSTRATION ONLY.

Installing an Ingenico Lane Reader on the Mounting System

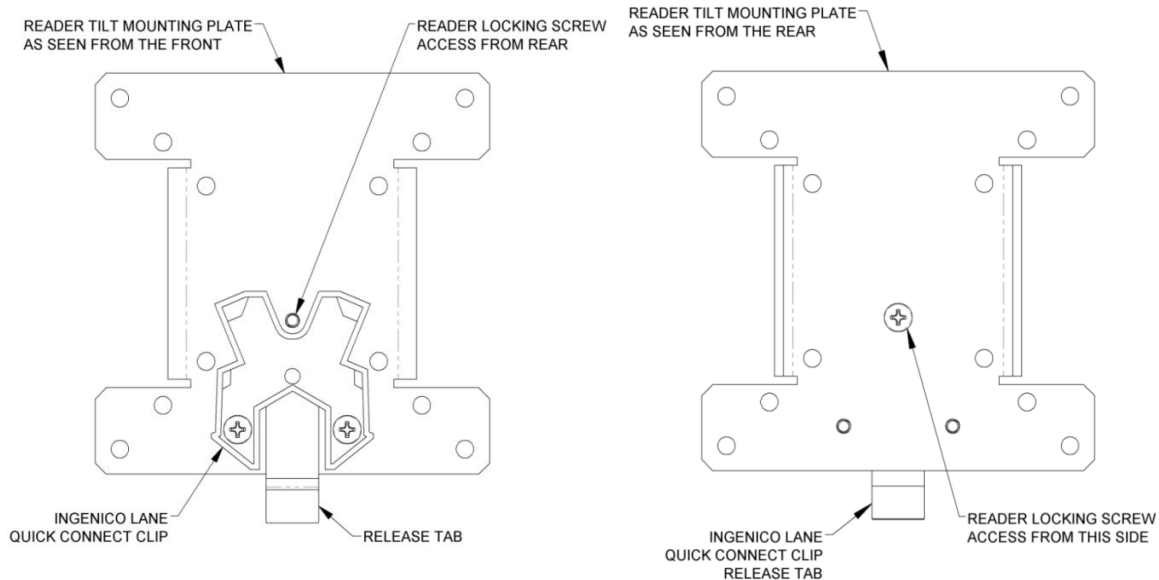

1. The reader power cable connector must be connected to the reader BEFORE the reader is installed on the mount. Refer to the Ingenico Lane Reader documentation for the procedure to attach the power cable connector to the top rear of the Ingenico reader.
2. Identify the “Y shaped raised section” on the quick connect clip on the pan and tilt head assembly and verify that the pan and tilt head is oriented so that the Y shaped section is pointing upwards as shown in the above image labeled “FRONT VIEW”.
3. Examine the “Y shaped recess” in the back of the reader and the matching “Y shaped raised section” on the quick connect clip on the pan and tilt head assembly and understand that these two components must be smoothly fit together to attach the reader to the mount.
4. Lift the reader and hold it so that the Y shaped recess in the back of the reader is aligned over the matching Y shaped raised section of the quick connect clip.
5. Carefully guide the reader down onto the mount; then slide the reader downwards about 1/4” of an inch until the raised section of the clip engages the recess in the reader and the two are securely locked together. Verify that the release tab on the clip is completely seated onto the slot on the back reader by pushing down on it slightly.
6. To permanently lock the reader to the pan and tilt head assembly; gently tighten the Phillips head lock screw on the rear of the tilt plate.
7. The reader power cable can be secured to the gray tube across the back of the reader pan and tilt head assembly with a cable tie or hook-look strap

SOME COMPONENTS DEPICTED MAY NOT BE INCLUDED IN YOUR PRODUCT ASSEMBLY, SHOWN FOR ILLUSTRATION ONLY.

Removing an Ingenico Reader from the Mounting System

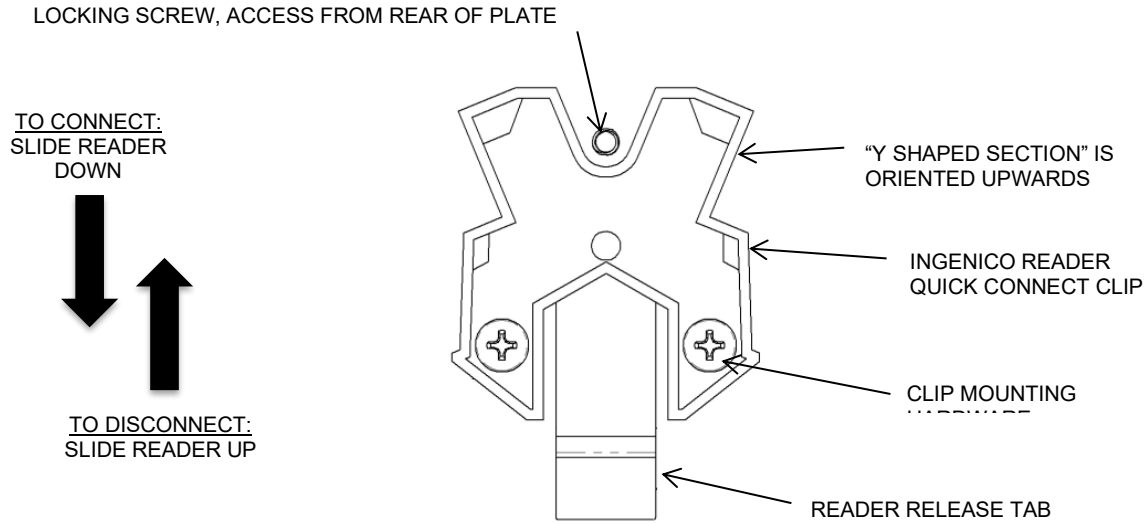

1. If a cable tie or hook-look strap are tightly securing the power cable to the back of the reader pan and tilt head assembly; remove the tie before proceeding.
2. Check that the lock screw on the back of the tilt plate is in the "unlocked" position. It should be unscrewed from the quick connect clip but not removed from the tilt plate.
3. Press the release tab on the quick connect clip so that it disengages from the slot on the back of the reader.
4. Slide the reader upwards about ¼" and carefully lift the reader off of the plate.

SOME COMPONENTS DEPICTED MAY NOT BE INCLUDED IN YOUR PRODUCT ASSEMBLY, SHOWN FOR ILLUSTRATION ONLY.

Attaching a VESA Screen to the Telescoping Pedestal Assembly

Important note: The SAME procedure is used to attach a VESA device to the VESA mounting plate for BOTH configuration types (Tilt Only, and Pan-Tilt).

1. Separate the Telescoping Pedestal sections from one another by removing the height adjustment knobs on the Left and Right sides of the lower-outer section. Twist counterclockwise to unscrew and completely remove them from the pedestal assembly. Set aside for later reinstallation.
2. Grasp the tilt plate of the upper-inner section and carefully remove the entire upper-inner section out of the lower-outer section.

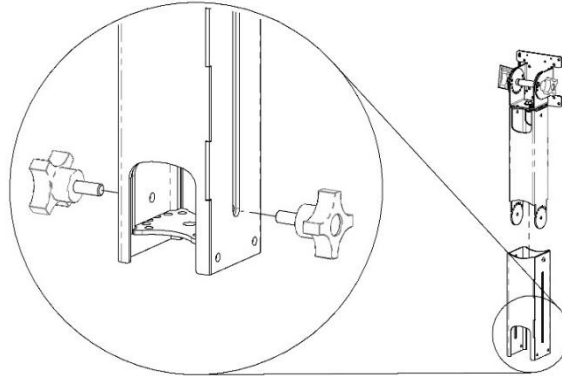

Install Screen on VESA Mounting Plate

1. Locate a section of clean kraft paper, cardboard or other material and lay this material on top of a smooth flat surface as large as the display. This will serve to protect your screen from damage in the next step.
2. Place your screen face down on the protective material in the desired orientation (portrait or landscape) so the intended top of the screen faces away from you. Note the square pattern of four VESA threaded mounting holes that are recessed into the back of the screen near the center.
3. Locate the bag of four M4x10mm VESA mounting screws attached to the VESA tilt plate at the factory.
4. Note which side of the Base Plate you would like your screen to face. Carefully lift the VESA tilt plate and the attached pedestal upper- inner section, orient the pedestal section with the bottom of the screen, align the four holes in the VESA tilt plate with the four threaded holes in the back of the screen and then carefully thread the M4 VESA screws through the holes in the plate and into each of the holes in the back of the screen. When all four screws have been started; use a Phillips screwdriver to carefully tighten each screw just until all of the edges of the plate are flush with the back of the screen.

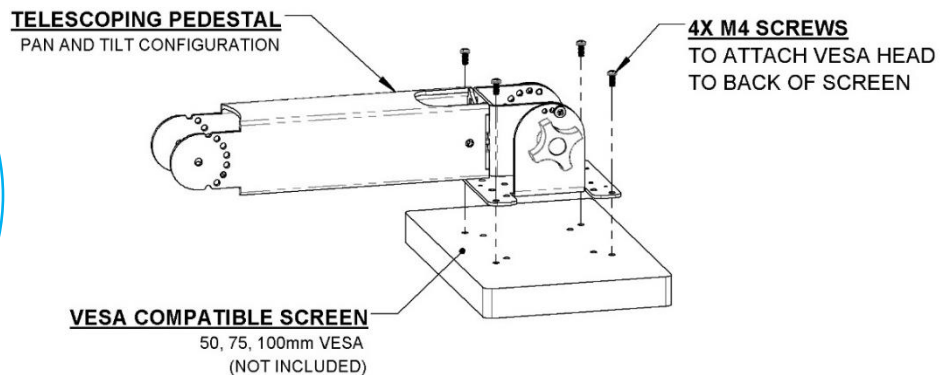

SOME COMPONENTS DEPICTED MAY NOT BE INCLUDED IN YOUR PRODUCT ASSEMBLY, SHOWN FOR ILLUSTRATION ONLY.

Assembling a Telescoping Pedestal, Part 1

Important note: As shipped the Pedestal Assembly will be partially disassembled. The Pedestal Mounting Bracket will be pre-attached to the 16X16 base plate at a location as specified in the drawings for the individual product assemblies. The main Telescoping Pedestal Assembly with VESA mounting plate will need to be attached to the pre-installed mounting bracket using the included hardware. Know that the pedestal assemblies can be easily reconfigured in the field.

Before proceeding, refer to the sections: **Understanding the Telescoping Pedestal Assembly; Understanding Telescoping Pedestal Configurations (Tilt Only vs Pan-Tilt); Relocating a Telescoping Pedestal Assembly (parts 1+2).**

Install the Lower-Outer Pedestal Section onto Base Assembly

1. Identify the Telescoping Pedestal assembly. Remove the two height adjustment knobs and then remove the upper-inner section from the lower-outer section. The screen will need to be attached to the VESA mounting plate on the upper-inner section and set aside. Understand that the inner section with screen attached will be reinstalled into the lower-outer section after mounting the lower section to the Base assembly. Refer to the section: **Attaching a VESA Screen to the Telescoping Pedestal Assembly**

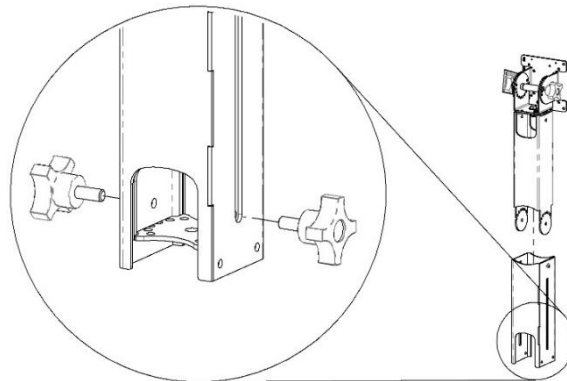

2. Locate the bag of four #10-32 X 3/8" L screws attached to the mounting base; Orient the lower-outer pedestal section so that the lower sides of the pedestal with two thru holes are aligned with the threaded holes in the tabs on the sides of the mounting bracket. Carefully lower the pedestal section down guiding the tabs on the mounting bracket into the lower end of the pedestal.
3. Once the pedestal is properly aligned; use a Phillips screw driver to loosely install the four #10-32 screws through the holes in the sides of the pedestal section into the mounting bracket threaded holes. Once all four screws are installed; return to each one and carefully tighten them.

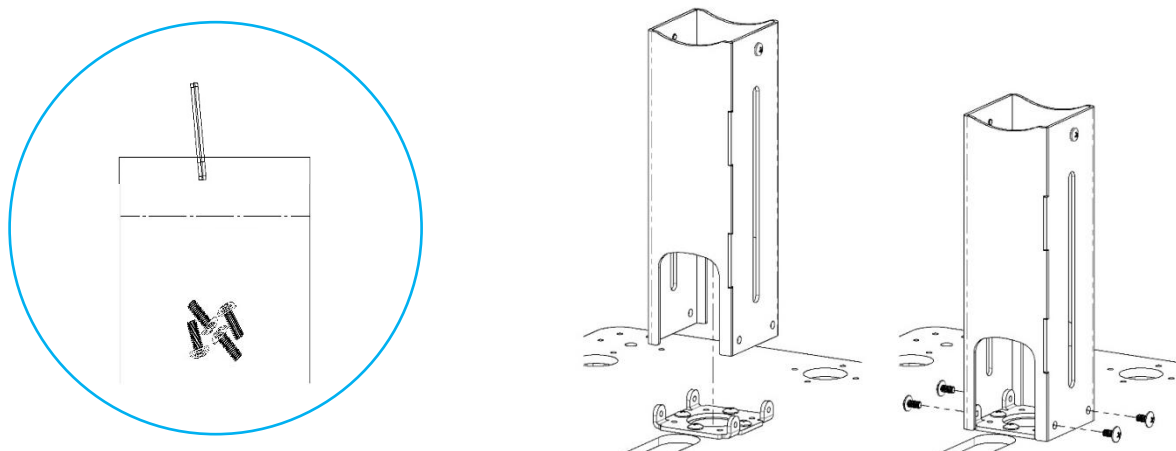

SOME COMPONENTS DEPICTED MAY NOT BE INCLUDED IN YOUR PRODUCT ASSEMBLY, SHOWN FOR ILLUSTRATION ONLY.

Assembling a Telescoping Pedestal, Part 2

Before proceeding, review the section; **Attaching a VESA Screen to the Telescoping Pedestal Assembly, Routing Cables Within a Telescoping Pedestal**. Once the screen has been attached to the VESA mounting plate and the cabling for the screen has been installed, you can proceed with the following assembly steps.

Reinstall the Upper-Inner Pedestal Section with Attached Screen

1. Verify that the pedestal height locking screws on the lower-outer section are slightly unscrewed and retracted from the inside of the pedestal section enough to allow the bottom of the upper- inner pedestal section to be inserted into the lower-outer pedestal section.
2. Carefully grasp and lift the screen with the attached tilt plate and the upper-inner pedestal section. Align the bottom of the upper-inner pedestal section so that the cable path cutouts are facing the same way as those on lower-outer section; then guide the bottom of the upper-inner pedestal section into the top opening of the lower-outer pedestal section. When the bottom of the upper-inner section makes contact with the button of the lower-outer section; you can release the screen.
3. Locate the two 5/16-18 four point pedestal height adjustment knobs set aside earlier. Install the threaded shafts of the two knobs through the slots on the sides of the lower-outer pedestal section and into the threaded holes in the inner-upper pedestal section. Tighten to secure. See section; **Adjusting the Vertical Height Position of the Telescoping Pedestal**

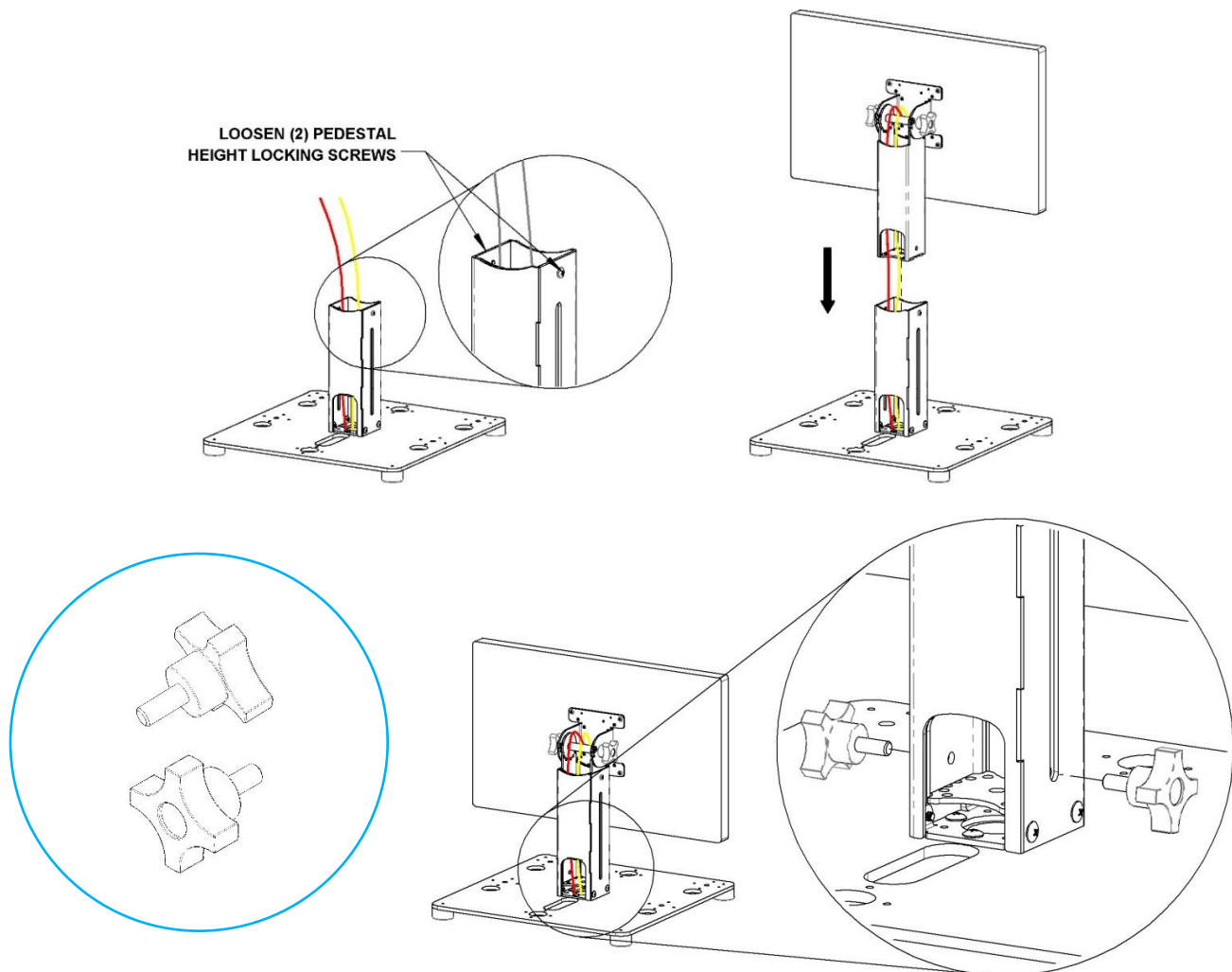

SOME COMPONENTS DEPICTED MAY NOT BE INCLUDED IN YOUR PRODUCT ASSEMBLY, SHOWN FOR ILLUSTRATION ONLY.

Relocating a Telescoping Pedestal Assembly (Part 1)

Important note: As shipped, the Pedestal Assembly will be partially disassembled. The Pedestal Mounting Bracket will be pre-attached to the 16X16 base plate at a location as specified in the individual product assembly drawings. Know that pedestal assemblies can be easily reconfigured in the field. Before proceeding, refer to the sections: Understanding the Telescoping Pedestal Assembly; Understanding How the Telescopic Pedestal Assembly Works with the 16X16 Base Plate.

Remove the Pedestal and Mounting Base

1. The pedestal assembly includes two separate sections; the upper-inner section and the lower-outer section. Locate the pedestal height adjustment knobs on the Left and Right sides of the lower-outer section. Twist both knobs counterclockwise to unscrew and completely remove them from the pedestal assembly. Set these aside for reinstallation. Loosen the two Phillips height lock screws on the sides of the pedestal so the upper-Inner Pedestal section is free to slide. Grasp the tilt plate of the upper-inner section and carefully remove the entire upper-inner section out of the lower-outer section.
2. If a screen is attached to the VESA mounting plate - disconnect and remove any cables as needed; then loosen the two height lock screws on the sides of the pedestal. Carefully grasp the edge of the screen and lift it up along with the attached upper-inner pedestal section until it is clear of the lower-outer section and set it aside.

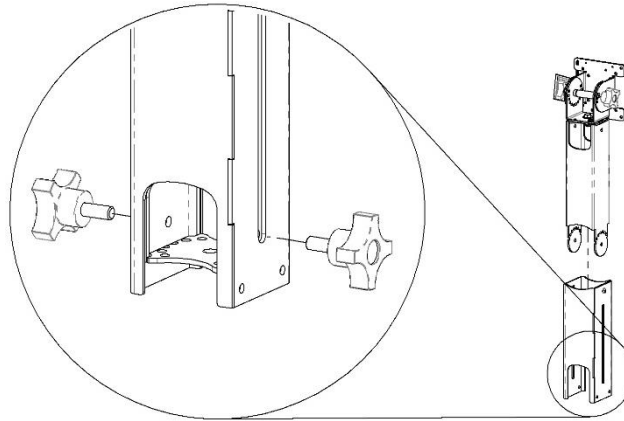

3. Separate the lower-outer pedestal section from the mounting base by removing four 10-32 X 3/8"L screws from the sides of the lower end of Lower-outer pedestal section, then lift the lower-outer pedestal section straight up and off the mounting bracket, and set aside with the hardware for reinstallation.
4. Separate the mounting bracket from the 16X16 Base Assembly by removing the remaining four 10-32 X 3/8"L screws which connect it to the 16X16 base plate, and set the hardware aside for reinstallation.

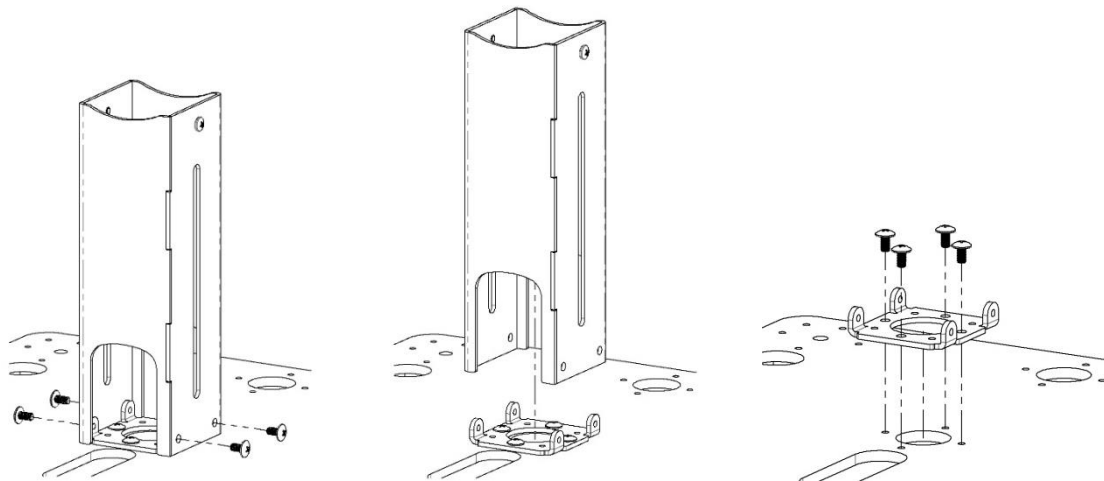

SOME COMPONENTS DEPICTED MAY NOT BE INCLUDED IN YOUR PRODUCT ASSEMBLY, SHOWN FOR ILLUSTRATION ONLY.

Relocating a Telescoping Pedestal Assembly (Part 2)

Important note: Refer to your product layout sketch to verify the intended new location of the pedestal and apply a small label using blue painters' tape adjacent to the new pedestal location. Draw a small arrow to indicate the intended front or cable path direction.

Reinstall Mounting Base and Lower Pedestal Section

1. Place the pedestal mounting bracket onto the base assembly in the new desired pedestal location. Understand that the orientation of this bracket will determine the orientation of the entire Pedestal assembly. Orient the mounting bracket side tabs such that they align with the intended sides of the lower pedestal section (sides with knobs and no cable path opening). For Tilt-Only assemblies, this will also affect the resulting tilt direction of attached screens.
2. Once you have verified the position and orientation of the mounting bracket; align the four thru holes on the mounting bracket with the four threaded holes in the 16X16 base plate at the intended mounting location, then use a Phillips screw driver to loosely install the four 10-32 screws removed earlier. Once all four screws are installed; return to each and carefully tighten them.
3. Hold the lower-outer pedestal section so that the sides with a pair of two thru holes is aligned with the tabs of the mounting bracket. Carefully lower the pedestal section down guiding the tabs in the mounting bracket into the lower end of the pedestal until it fully contacts the 16x16 base assembly.
4. Once the pedestal is properly aligned; use a Phillips screw driver to loosely install the four 10-32 screws removed earlier through the holes in the side of the pedestal section and into the threaded holes on the tabs of the mounting bracket. Once all four screws are installed; return to each one and carefully tighten them.

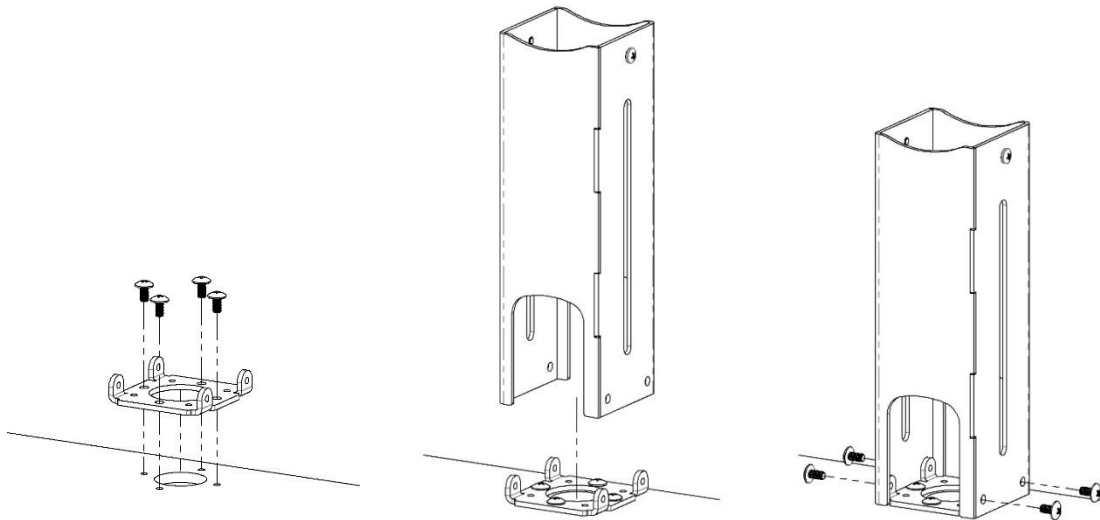

SOME COMPONENTS DEPICTED MAY NOT BE INCLUDED IN YOUR PRODUCT ASSEMBLY, SHOWN FOR ILLUSTRATION ONLY.

Relocating a Telescoping Pedestal Assembly (Part 3)

Important note: Verify that the pedestal height screws are retracted and slightly unscrewed from the lower-outer pedestal section enough to allow the bottom of the upper-inner pedestal section to be fully inserted into the top opening of the lower-outer pedestal section.

Reinstall Upper Pedestal Section and Associated Cabling

1. Reroute the associated cabling to the new pedestal location and reconnect the cables to the screen as needed. Three of the seven pedestal attachment locations along the center of the plate include a concealed cable path hole located directly below the pedestal. Four locations have cable passage holes adjacent to the pedestal position. See section: **Understanding How the Telescoping Pedestal Assembly Works with the 16X16 Base Plate**
2. Carefully grasp and lift the screen with the attached tilt plate and the upper- inner pedestal section. Align the bottom of the upper- inner section so that the cable path cutouts are facing the same way as those on lower-outer section; then guide the bottom of the upper- inner section into the top of the lower-outer section. When the bottom of the upper- inner section makes contact with the button of the lower-outer section; you can release the screen.
3. Re-install the pedestal height adjustment knobs into the desired height adjustment slots, adjust the height of the screen, adjust the screen pan and tilt to the desired positions and then tighten height and screen pan and tilt locking screws.

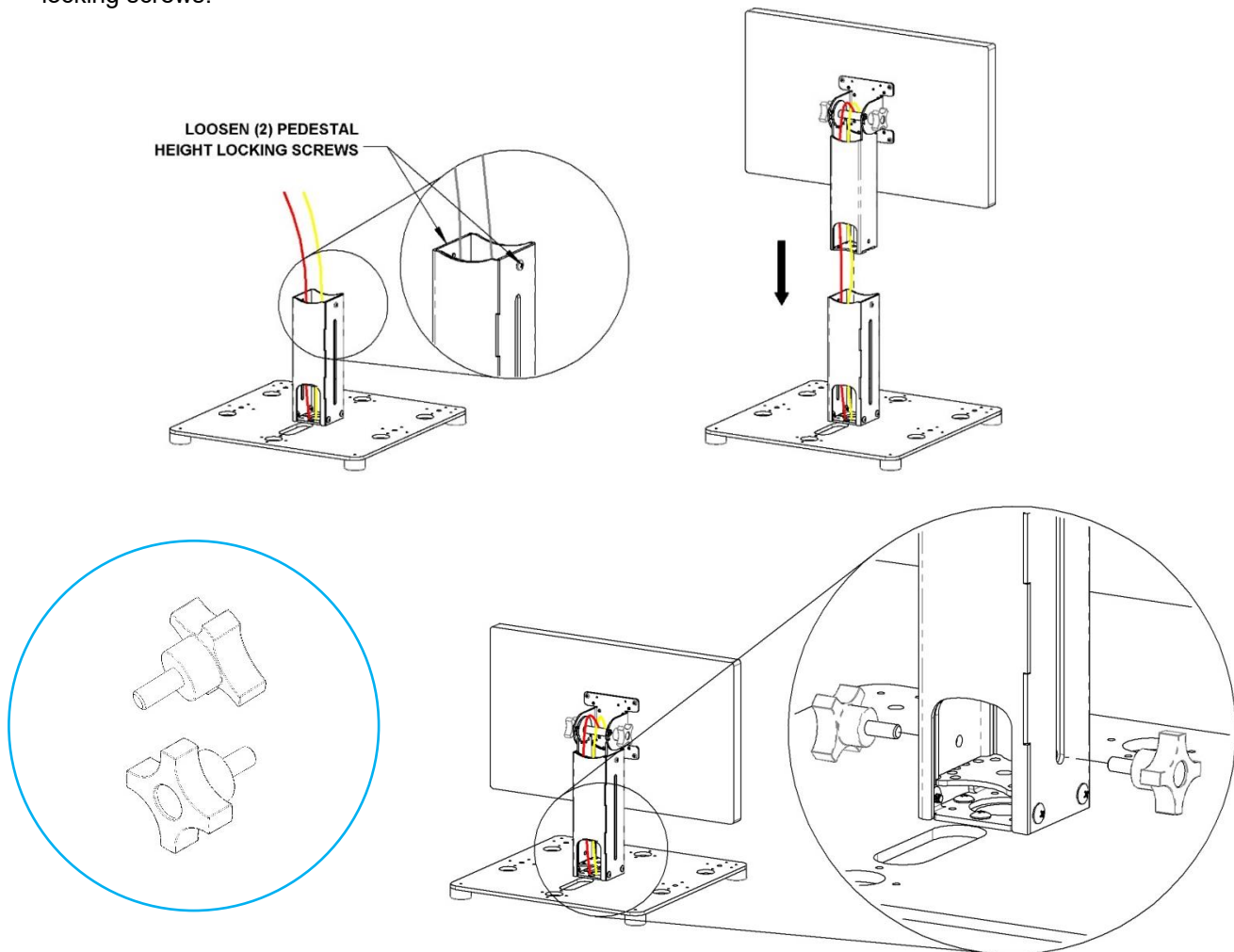

SOME COMPONENTS DEPICTED MAY NOT BE INCLUDED IN YOUR PRODUCT ASSEMBLY, SHOWN FOR ILLUSTRATION ONLY.

Adjusting the Arm Stop Position of a Riser Assembly

Important note: Understand that the position of the stop on the side of the riser indicates the location where the arm cannot be rotated past and is thereby restrained from completing a full 360 degree circle around the top of the Riser assembly. The mounting bolt is a 5/16-18 HEX head type that requires a 1/2" or adjustable wrench. The riser stop screw requires a #2 Phillips screwdriver. Both fasteners are located on the underside of the base plate.

Before proceeding: You must remove all equipment AND the supporting sub-assemblies such as screens, printers, readers, Pan-tilt heads, printer - peripheral trays, etc. that are installed on the arms of the Risers and the top of the pedestal assemblies.

There are a few methods that can be used to safely access the riser mounting fasteners:

- **Option 1:** Have an assistant restrain and steady the 16X16 Base plate assembly and then slowly and carefully slide the edge of the plate off of the edge of the counter top until you can access the fasteners for the riser.
- **Option 2:** Locate two or more sturdy, flat topped items such as milk crates that are 8" tall or taller that can serve as temporary structures to support the entire weight of the 16X16 Base plate assembly and then have an assistant help lift and restrain assembly while you access the fasteners on the underside of the Base Plate.
- **Option 3:** With the help of an assistant; lift the 16X16 Base plate assembly and then slowly and carefully lower the Base plate assembly so that one edge of the plate rests on the countertop. Have the assistant restrain the plate from moving while you access the fasteners for the riser.

To Reset the Position of the Riser Stop

After evaluating the side-to-side range of motion of the arm that is attached to the Riser Cap and determining the desired location for the Angle Stop:

1. Loosen the 10-32 Phillips head riser lock screw on the underside of the Base Plate using a #2 Phillips screwdriver.
2. Loosen the 5/16-18 bolt using a 1/2" wrench.
3. Carefully rotate the riser to place the cylindrical stop on the side of the riser in the new desired orientation as indicated by the small section of tape applied earlier.
4. Hold the riser firmly so that the stop is aligned with the new location and is prevented from turning; and then carefully retighten the bolt and screw.

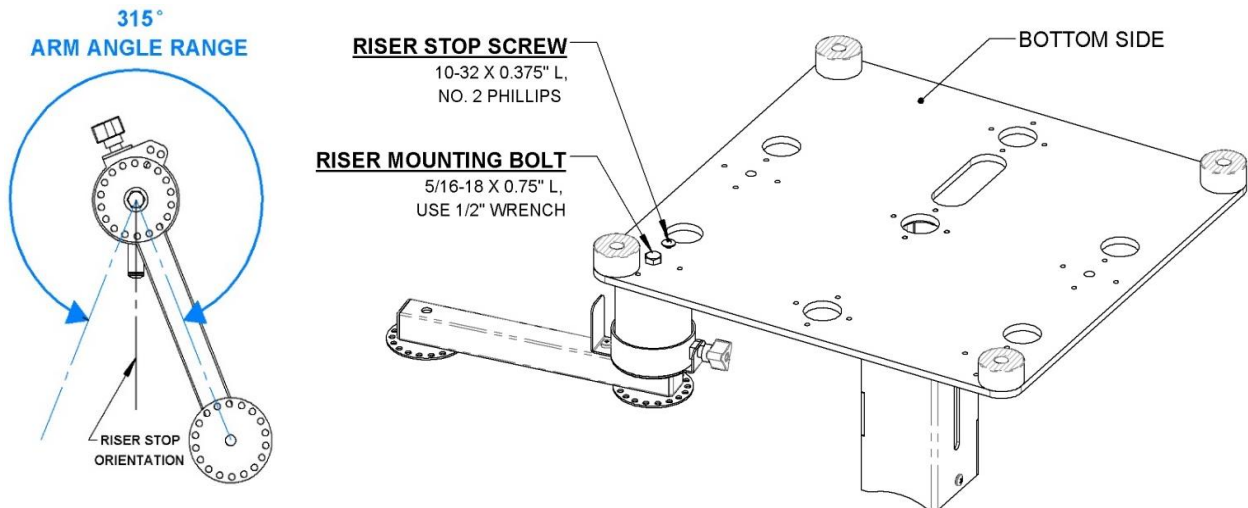

SOME COMPONENTS DEPICTED MAY NOT BE INCLUDED IN YOUR PRODUCT ASSEMBLY, SHOWN FOR ILLUSTRATION ONLY.

Relocating a Riser Assembly (Part 1)

Important note: As shipped from the factory; all riser assemblies will be pre-attached to the Base Plate as detailed in the associated images and drawings for each product assembly; however the location of any riser assemblies can be changed in the field with common tools.

Before proceeding: you must remove any sub-assemblies and equipment along with the Pan-tilt assembly and printer peripheral tray from the end of all riser arms. Disconnect and remove any cabling as needed. Review the following sections: **Understanding the functionality of the Base Plate;** **Understanding the functionality of the Telescoping Pedestal;** **Understanding the functionality of the Riser Assemblies**

- Apply a small section of blue painter's tape onto the base plate adjacent to the new location of the riser, and designate the intended orientation of the Riser by drawing a small arrow using permanent marker.
- The riser mounting bolt is a 5/16-18 HEX head type that requires a 1/2" or an adjustable wrench, the riser lock screw requires a #2 Phillips screwdriver. Both fasteners are located on the underside of the base plate.

There are a few methods that can be used to safely access the riser mounting fasteners:

- **Option 1:** Have an assistant restrain and steady the 16X16 Base plate assembly and then slowly and carefully slide the edge of the plate off of the edge of the counter top until you can access the fasteners for the riser.
- **Option 2:** Locate two or more sturdy, flat topped items such as milk crates that are 8" tall or taller that can serve as temporary structures to support the entire weight of the 16X16 Base plate assembly and then have an assistant help lift and restrain assembly while you access the fasteners on the underside of the Base Plate.
- **Option 3:** With the help of an assistant; lift the 16X16 Base plate assembly and then slowly and carefully lower the Base plate assembly so that one edge of the plate rests on the countertop. Have the assistant restrain the plate from moving while you access the fasteners for the riser.

To Remove a Riser Assembly

1. Remove the 10-32 Phillips head riser lock screw from the underside of the Base Plate using a #2 Phillips screwdriver and set aside for reinstallation.
2. Hold the riser firmly so that the is does not rotate and remove the 5/16-18 bolt from the underside of the Base Plate using a 1/2" wrench and set aside for reinstallation.

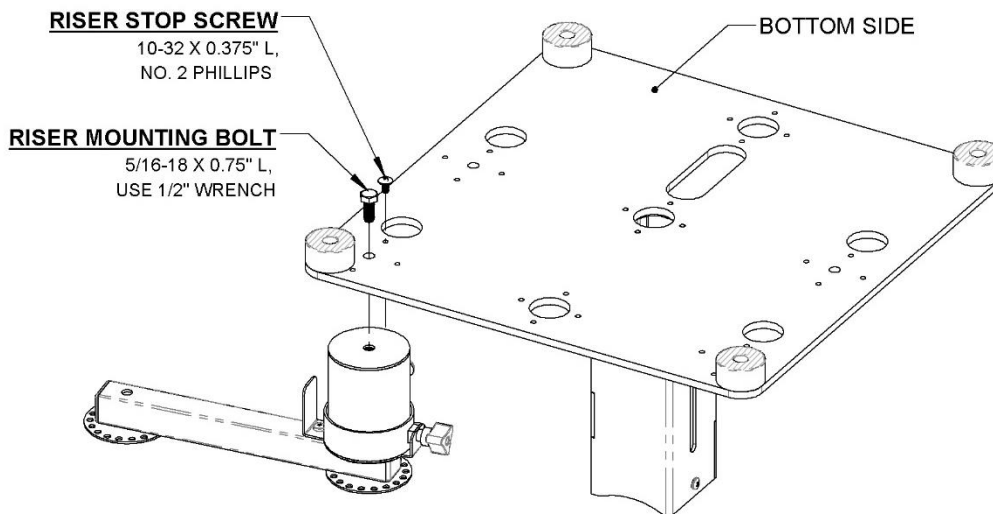

SOME COMPONENTS DEPICTED MAY NOT BE INCLUDED IN YOUR PRODUCT ASSEMBLY, SHOWN FOR ILLUSTRATION ONLY.

Relocating a Riser Assembly (Part 2)

Important note: As shipped from the factory; all riser assemblies will be pre-attached to the Base Plate as detailed in the associated images and drawings for each product assembly; however the location of any riser assemblies can be changed in the field with common tools.

Before proceeding: you must remove any sub-assemblies and equipment along with the Pan-tilt assembly and printer peripheral tray from the end of all riser arms. Disconnect and remove any cabling as needed. Review the following sections: **Understanding the functionality of the Base Plate;** **Understanding the functionality of the Telescoping Pedestal;** **Understanding the functionality of the Riser Assemblies**

- Apply a small section of blue painter's tape onto the base plate adjacent to the new location of the riser, and designate the intended orientation of the Riser by drawing a small arrow using permanent marker.
- The riser mounting bolt is a 5/16-18 HEX head type that requires a 1/2" or an adjustable wrench, the riser lock screw requires a #2 Phillips screwdriver. Both fasteners are located on the underside of the base plate.

There are a few methods that can be used to safely access the riser mounting fasteners:

- **Option 1:** Have an assistant restrain and steady the 16X16 Base plate assembly and then slowly and carefully slide the edge of the plate off of the edge of the counter top until you can access the fasteners for the riser.
- **Option 2:** Locate two or more sturdy, flat topped items such as milk crates that are 8" tall or taller that can serve as temporary structures to support the entire weight of the 16X16 Base plate assembly and then have an assistant help lift and restrain assembly while you access the fasteners on the underside of the Base Plate.
- **Option 3:** With the help of an assistant; lift the 16X16 Base plate assembly and then slowly and carefully lower the Base plate assembly so that one edge of the plate rests on the countertop. Have the assistant restrain the plate from moving while you access the fasteners for the riser.

To Install a Riser Assembly

1. Align the threaded hole in the bottom of the riser assembly with the central hole in any of the Riser Mounting Positions on the Base Plate assembly. Review section: **Understanding How the Riser Assembly Works with the 16X16 Base Plate**
2. Orient the cylindrical stop on the side of the riser in the direction as indicated by the small arrow drawn earlier. This determines the available range of motion for the entire Riser Arm assembly.
3. Hold the riser firmly so that the stop is kept properly aligned and the riser is prevented from turning; then carefully install the 5/16-18 bolt using a 1/2" wrench. Tighten fully.
4. Reinstall the Riser lock screw into (1) of the (4) available threaded holes in the Base Plate mounting pattern, and tighten until the screw makes contact with the underside of the riser assembly to prevent rotation.

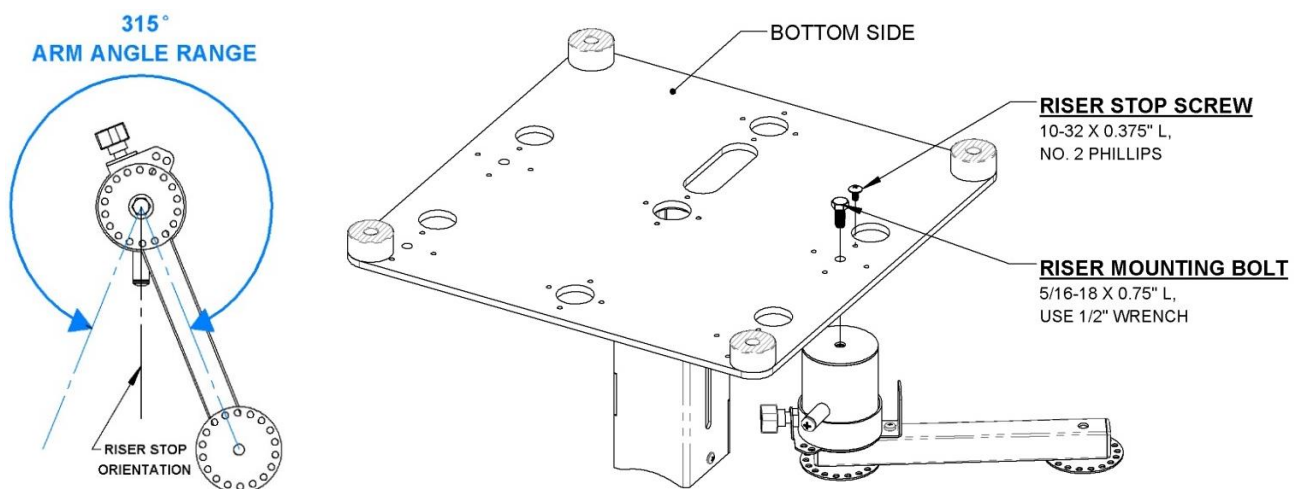

SOME COMPONENTS DEPICTED MAY NOT BE INCLUDED IN YOUR PRODUCT ASSEMBLY, SHOWN FOR ILLUSTRATION ONLY.

Planning the Installation of the Cabling to the Countertop Stand

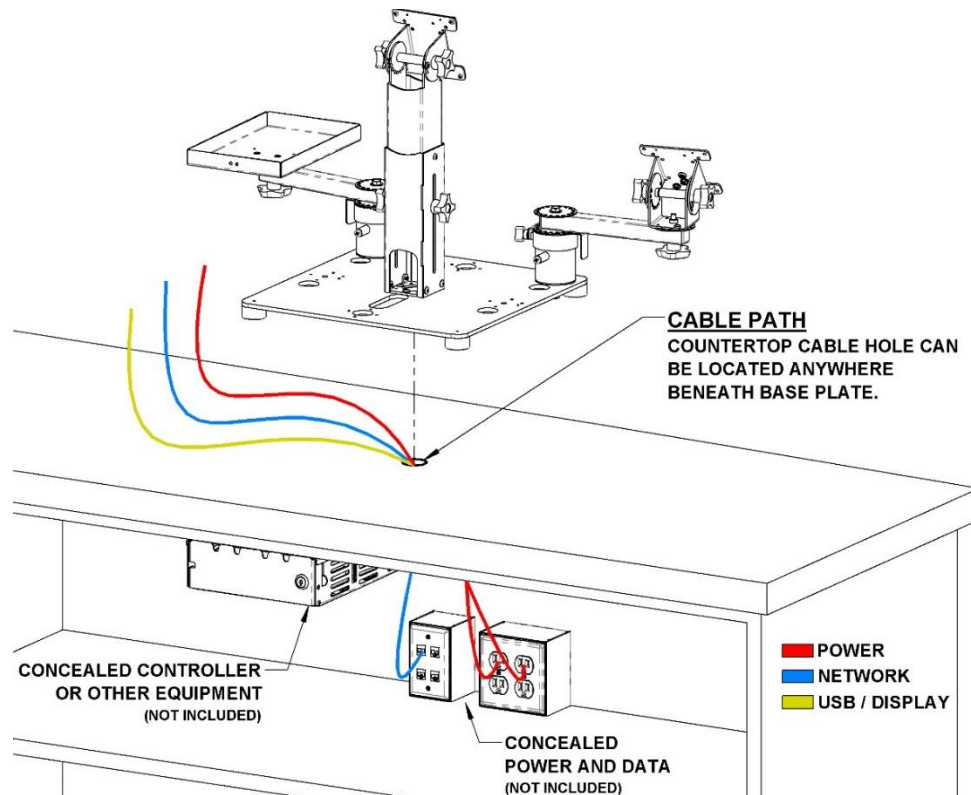

- Once your system is installed on the counter top; but BEFORE the equipment is installed; route all of the associated cabling to the future equipment locations. Be sure to provide enough slack cable at each equipment location to allow unrestricted freedom of movement and adjustment.
- The 16X16 base plate has six cable passage holes and one large slot that allow cabling to enter from pedestals, risers or equipment installed directly on top of the base plate or from any side of the plate.
- The large cable passage slot is usually used to route cable from peripheral equipment to a POS terminal that is installed at the rear of the base plate over the slot.
- •The entire base plate is raised $\frac{3}{4}$ " above the countertop to allow cabling to be routed out of sight across the underside of the plate.
- •After all of the associated cabling is routed into the cable passage holes-slot and across the underside of the plate; it can then be routed down into a cable passage hole in the countertop where it will be connected to the power and data outlets located below the countertop.
- •In depth explanations for routing cabling to the equipment installed on the system are covered in the various sections detailing how the pedestal and risers work with the base plate and the sections related to installing the pedestal and risers.
- •Cabling can also be routed from equipment that is installed adjacent to the 16X16 Base Plate by carefully lifting the base plate and then installing the cabling up thru the cable passage holes-slot to connect to equipment installed on the plate or across the underside of the plate and down into a cable passage hole in the countertop.
- •There are four attachment locations where Riser assemblies with adjustable arms can be attached to the top of the Base Plate; each has an adjacent cable path hole. Cabling can be attached directly to the arm and to a cable tie point on the Riser Cap assembly

SOME COMPONENTS DEPICTED MAY NOT BE INCLUDED IN YOUR PRODUCT ASSEMBLY, SHOWN FOR ILLUSTRATION ONLY.

Routing Cables Through a Telescoping Pedestal Assembly

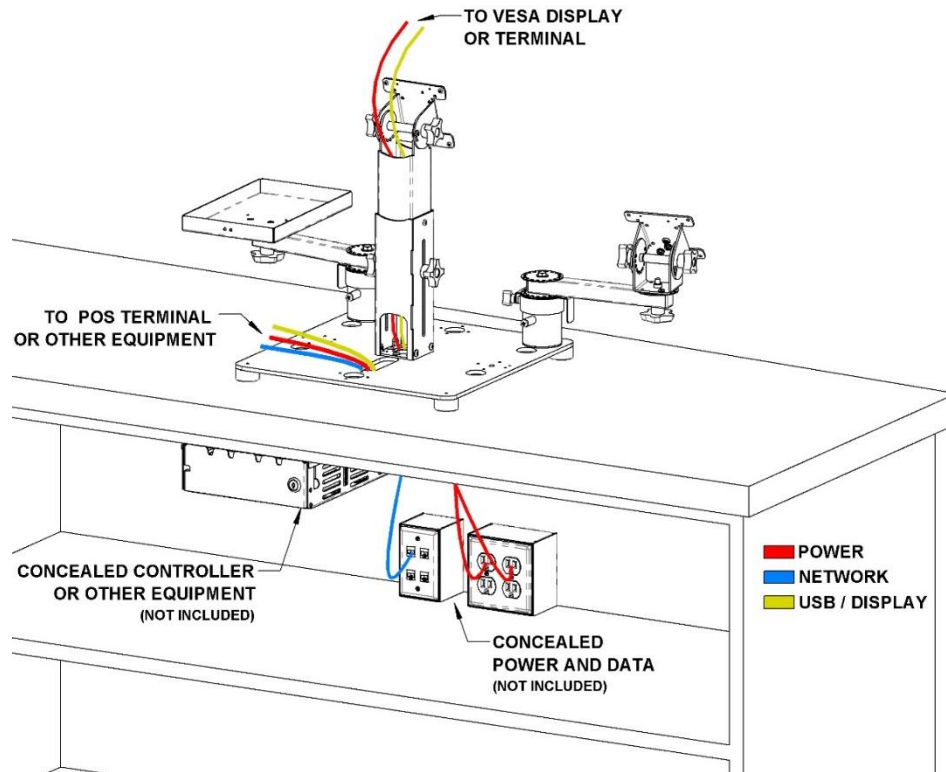

- The telescopic pedestal mount is designed to allow cabling to be routed inside of both of the inner-upper and outer-lower square tubular sections. The 16X16 base plate has six cable passage holes and one large slot that allow cabling to enter from pedestals, risers or equipment installed directly on top of the base plate or from any side of the plate.
- Three of the seven pedestal attachment locations along the center of the plate include concealed cable path holes directly below the pedestals. Four locations have cable passage holes adjacent to the pedestal base.
- Use hook and loop strips and cable ties from the included Cable Management Kit to secure the cables directly to the gray plastic spacer behind the VESA Tilt plate on the top of the upper-inner pedestal section.
- When routing cables to telescopic pedestal assemblies, be sure to leave enough slack on the cables so that they will be able to reach the screens on the top of the pedestal AND to allow the upper-inner pedestal section to be moved to its fully extended and highest position. Slack and excess cabling can be bundled within the pedestal assembly using included hook and loop straps.

SOME COMPONENTS DEPICTED MAY NOT BE INCLUDED IN YOUR PRODUCT ASSEMBLY, SHOWN FOR ILLUSTRATION ONLY.

Routing Cables to a Riser Assembly

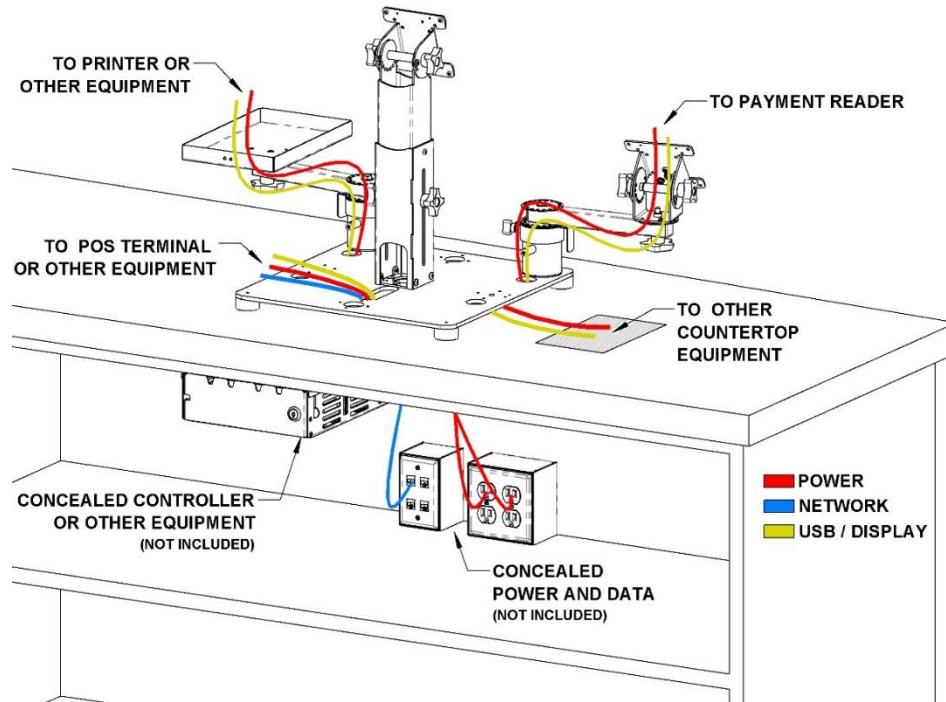

- There are four attachment locations where Riser assemblies with adjustable arms can be attached to the top of the Base Plate; each has an adjacent cable path hole.
- One end of the arm is permanently attached to the Riser Cap and Riser and the free end of the arm can support either a printer tray or a Pan and Tilt head assembly that can support a up to a 12" class VESA compatible screen or a variety of EMV readers.
- Cabling can be attached directly to the arm and to a cable tie point on the Riser Cap assembly. Use hook and loop straps or cable ties to secure the cables directly to the arm and to the cable tie point provided on the Riser Cap assembly
- If a POS printer is installed on the tray; the power supply cable can be installed behind the printer on the tray if the surplus associated cabling is tightly bundled. Cabling can be routed thru the 1/4" DIA cable passage hole in the rear of the tray and can be attached directly to the arm with cable ties or hook and loop straps.
- When routing cables to riser assemblies, be sure to leave enough slack on the cables so that they will be able to reach the equipment attached to the ends of the adjustable arms and to allow free side to side movement of the arms around the tops of the risers

SOME COMPONENTS DEPICTED MAY NOT BE INCLUDED IN YOUR PRODUCT ASSEMBLY, SHOWN FOR ILLUSTRATION ONLY.

Understanding the Two Cables on Most Power Bricks



- **Cable "A"**: is a high voltage cable input to the power brick and has a standard plug on one end that is connected to a standard 110VAC power receptacle; note that this cable will often have a plug on the other end that often can be easily disconnected and reconnected from the power brick.
- **Cable "B"**: is a low voltage cable that often has one end permanently attached to the power brick and the other end will have a plug that connects to the power jack on the back of the peripheral device.

If the low voltage power cable for your screen is permanently attached

- **Option 1**: The screen power brick can be installed out of sight below the counter top with the high voltage power cable connected to a power outlet below the counter top and the low voltage power cable routed up through the counter top, through the base plate, through the pedestal assembly and then connected to the screen. This method is usually the most desired as the power brick is not visible.
- **Option 2**: The screen power brick can be installed at the base of the pedestal or on the adjacent counter top with the low voltage power cable routed up through the pedestal assembly to the screen and the high voltage cable being routed down through the base plate, through the counter top and then will be connected to a power outlet below the counter top. This method is less desirable as the power brick is visible on the counter top area.
- **Option 3**: The screen power brick and associated cabling can be attached to the rear of the screen with cable ties, hook and loop strapping or for a cleaner installation; use PQS PN 80510 Universal Back of Screen Power Supply Holder. (see image) This method is less desirable; but the power brick is only visible from the rear of the screen.

SOME COMPONENTS DEPICTED MAY NOT BE INCLUDED IN YOUR PRODUCT ASSEMBLY, SHOWN FOR ILLUSTRATION ONLY.

On page SEO - Movable Countertop POS Stands

Countertop stand system for Point of Sale (POS) terminal, printer, customer display, rear marketing display and payment terminal or pin pad.

- Movable Point of Sale (POS) Countertop Stand
- Point of Sale (POS) Kiosk
- Point of Sale (POS) Terminal Display Stand
- Countertop Support System for Point of Sale (POS)
- Countertop Cashier Stand for Point of Sale (POS)
- VESA POS Mounting Solution with arms for printer and pin pad holder.
- Through Countertop Cashier Stand for Point of Sale (POS)

Compatible Point of Sale (POS) Systems:

MICROS ORACLE; Lightspeed; Logic Controls; Bematech; NCR; Aloha; Elotouch; Posiflex; Poster POS; ehopper; Beetronics; Tyso; Favpng; Touch Dynamic; FastSpring; CAKE; Erply; Sapaad; Upserve; Salesforce; Commerce Cloud; Block; Miva Merchant; Epos Now; QuickBooks POS; Shopify; VEND; Revel; Clover; CovaPOS; Oracle NETSUITE; GoDaddy; Helcim; Upserve POS; Elo; CardConnect; ALOHA; SQUARE; POSnation; KORONA POS; TOAST; Touchbistro; LAVU; Partnertech;

Also supports any VESA Compatible device (50mm, 75mm or 100mm).

Partial List of compatible printers that fit our Printer Trays:

Printer Tray Interior Dimensions: 6½" W X 10¼" L X 1" D:

Anser U2, Brother QL 800, Brother PTP700, Citizen CT-E351, Clover P500, Clover Mini, Custom America CT-E351, Dymo LabelWriter 450, Dymo LabelWriter Wireless, Dymo LabelManager PnP, Epson TM-T88V/VI, Epson TM- T20II, EpsonTM-U220 Type B & D, POS-X Evo HiSpeed, Rollo Printer, Sato FX3-LX, Sato WS2, Square Terminal, Star Micronics mC-Print3, Toast Receipt Printer TP200, Toast Kitchen printer TKP300, Toast Item Label Printer TLP400, Elo Pay

Movable Countertop Point of Sale Stands

Direct Mount Countertop Point of Sale Stands

Point of Sale (POS) Countertop Kiosk; Point of Sale (POS) Terminal Display Stand with Arms; Countertop Point of Sale (POS) Support System; Cashier Countertop Stand with Arms; VESA Point of Sale (POS) Mounting Solution with Arms for Printer and Pin Pad Holder; Countertop Cashier Stand for Point of Sale (POS) Terminal, Printer, Customer Display, Rear Marketing Display and Pin Pad or Payment Terminal; On Counter Point of Sale (POS) Mounting System; Above Counter Point of Sale (POS) Mounting System; Through Counter Point of Sale (POS) Mounting System.

Self-Check Out Kiosk Stands

Point of Sale (POS) Self-Service Kiosk; Self-Service Point of Sale (POS) Terminal Display with Arms; Point of Sale (POS) Self-Check Out (SCO) Support System; Self-Service Stand with Arms; VESA Self-Service Point of Sale (POS) Mounting Solution with Arms for Printer and Pin Pad Holder; Self-Service Stand for Point of Sale (POS) Terminal, Printer, Customer Display, Rear Marketing Display and Pin Pad or Payment Terminal; Self Check Out (SCO) Solution, Interactive Kiosk, Self-Ordering Kiosk Stand, Self-Checkout Kiosk Stand, Self Service Kiosk Stand,

